



FLOWSIC100 Flare-XT

GAS FLOW MEASURING INSTRUMENTS

SICK
Sensor Intelligence.



Ordering information

Type	Part no.
FLAWSIC100 Flare-XT	On request

In accordance with Article 2 (4), this product does not fall within the scope of RoHS directive 2011/65/EU and is also not designed for use in products which fall within the scope of this directive. You can find additional information in the product information.

The exact device specifications and performance data of the product may deviate from the information provided here, and depend on the application in which the product is being used and the relevant customer specifications.

Our regional sales organization will help you to select the optimum device configuration.

Other models and accessories → www.sick.com/FLAWSIC100_Flare-XT

Product description

Precise and robust gas flow meter for flare gas or flare stack applications: Our ultrasonic gas flow measuring instrument FLOWSIC100 Flare-XT is designed for flare gas measurement or flare metering. The high-resolution measurement and innovative sensor design is being developed for most efficient uses in petroleum refineries, natural gas processing or offshore and onshore oil and gas plants. Emission control or monitoring, detection of flare gas leaks, steam flow measurement, monitoring of gas losses, monitoring of steam injection in flare gas burning, as well as process optimization and condition monitoring are fields of use for this gas flow meter. The gas flow meter is measuring values such as gas velocity, gas volume and mass, mass flow rate, molecular weight, volumetric flow a. c., volumetric flow s. c. and sound velocity. The flare gas flow meter provides an intelligent device monitoring process and supports predictive maintenance - designed for current and future challenges.

At a glance

- Reliable measurement even at high gas velocities and with changing gas compositions
- Proprietary measuring range extension for high flow velocities thanks to ASC technology
- Direct mass flow calculation without additional gas analyzers
- Intuitive FLOWgate™ software for commissioning, operation and diagnostics
- I-diagnostics™: self monitoring, self testing and predictive maintenance
- Customized measurement performance thanks to individual evaluation of the application

Your benefits

- Several standards and guidelines for flare gas measurement are observed
- Maximum plant availability
- Ultrasonic sensors, Interface Unit, Spool Piece from a single source as well as globally available services
- Compatible with current and future communication architectures
- Independent maintenance through verification on demand and support by SICK when required
- Easy replacement of existing measurement systems, with suitable retrofit or upgrade solutions available



Fields of application

- Flare gas measurement for the production and processing of natural gas and associated petroleum gases (APG) in oil production.
- Flare gas measurement in chemical and petrochemical plants as well as refineries
- Measurement of LNG boil-off gas down to -196 °C
- Plants onshore and offshore
- Flare gas containing H_2S , CO_2 and H_2

Detailed technical data

FLOWSIC100 Flare-XT system

Measured values	Mass flow rate, volumetric flow s. c. (standard condition), volumetric flow a. c. (actual condition), molecular weight, gas volume and mass, gas velocity, sound velocity
Number of measuring paths	Single path, Dual path
Measurement principle	Ultrasonic runtime difference measurement, ASC technology (ASC = active sound correlation)
Measuring medium	Typical flare gas
Measuring ranges	0,03 m/s ... 120 m/s ¹
Measuring span	Up to 4000:1 ¹
Repeatability	(acc. to ISO 5725-1; JCGM 200:2012): < 0.5 % of the measured value in the range $\geq 1\text{ m/s}$
Resolution	(acc. to JCGM 200:2012): + 0.001 m/s
Uncertainty of measurement¹⁻³	
Volumetric flow, a. c. :	1 % ... 5 % Related to the measured value with ultrasonic technology (in the range $\geq 0.3\text{ m/s}$ to measuring range end value) 0,5 % ... 1,5 % with Spool Piece and flow calibration Related to the measured value with ultrasonic technology (in the range $\geq 1\text{ m/s}$ to calibration range end value) ⁴
Mass flow rate :	2 % ... 5.5 % Related to the measured value with ultrasonic technology (in the range $\geq 0.3\text{ m/s}$ to measuring range end value) 1,5 % ... 2 % with Spool Piece and flow calibration Related to the measured value with ultrasonic technology (in the range $\geq 1\text{ m/s}$ to calibration range end value) ⁴
Nominal pipe size	
1-path measurement:	4 " ... 72 "
2-path measurement:	12 " ... 72 "
	Other nominal sizes on request
Ambient humidity	$\leq 95\%$ Relative humidity
Conformities	ATEX: 2014/34/EU EMC: 2014/30/EU RoHS: 2011/65/EU PED: 2014/68/EU
Electrical safety	IEC 61010-1

General technical information for ultrasonic sensors

Ambient temperature	
Sensors, ignition group IIC T4:	$-40\text{ °C} \dots +70\text{ °C}$
Sensors, ignition group IIC T4:	$-50\text{ °C} \dots +70\text{ °C}$ (optional)
Sensors, ignition group IIC T6:	$-40\text{ °C} \dots +55\text{ °C}$

Sensors, ignition group IIC T6:	-50 °C ... +55 °C (optional)
Storage temperature	-40 °C ... +70 °C -50 °C ... +70 °C (optional)
Enclosure rating	IP66 / IP67
Dimensions (W x H x D)	For details see dimensional drawings

F1F-S

Gas temperature	-196 °C ... +280 °C
Operating pressure ¹	<p>CL150 device flange : 20 bar (g)</p> <p>PN25 device flange (optional) : 20 bar (g)</p> <p>CL300 device flange (optional) : 20 bar (g)</p> <p>¹ Temperature dependent. For details, see section Application ranges.</p>
Ex-approvals	<p>IECEX Ex db [ia Ga] IIA T4 Ga/Gb Ex db [ia Ga] IIB T4 Ga/Gb Ex db [ia Ga] IIC T6 Ga/Gb Ex ia IIC T6 Ga</p> <p>ATEX II 1/2G Ex db [ia Ga] IIA T4 Ga/Gb II 1/2G Ex db [ia Ga] IIB T4 Ga/Gb II 1/2G Ex db [ia Ga] IIC T6 Ga/Gb II 1G Ex ia IIC T6 Ga</p> <p>NEC/CEC (US/CA) Class I, Division 1, Group D, T4 Class I, Zone 1, Ex/AEx d[ia] IIA, T4 Class I, Division 2, Group D, T4 Class I, Zone 2, Ex/AEx nA[ia] IIA, T4 Class I, Division 1, Groups C and D, T4 Class I, Zone 1, Ex/AEx d[ia] IIB, T4 Class I, Division 2, Groups C and D, T4 Class I, Zone 2, Ex/AEx nA[ia] IIB, T4 Class I, Division 1, Groups B, C and D, T4 Class I, Zone 1, Ex/AEx d[ia] IIB + H2, T4 Class I, Division 2, Groups A, B, C and D, T4 Class I, Zone 2, Ex/AEx nA[ia] IIC, T4</p>
Weight	≤ 12 kg (Ultrasonic sensor pair)

F1F-H

Gas temperature	-70 °C ... +280 °C
Operating pressure	<p>CL150 device flange¹: ATEX/IECEX: 20 bar(g) CSA: 16 bar(g)</p> <p>PN25 device flange (optional)¹: ATEX/IECEX: 20 bar(g) CSA: 16 bar(g)</p> <p>CL300 device flange (optional)¹: ATEX/IECEX: 20 bar(g) CSA: 16 bar(g)</p> <p>¹ Temperature dependent. For details, see section Application ranges.</p>
Ex-approvals	

	IECEX	Ex db IIC T6 Gb
	ATEX	II 2G Ex db IIC T6 Gb
	NEC/CEC (US/CA)	Class I, Division 1, Groups B, C and D, T4 Class I, Zone 1, Ex/AEx d[ia] IIB + H2, T4 Class I, Division 2, Groups A, B, C and D, T4 Class I, Zone 2, Ex/AEx nA[ia] IIC, T4
Weight		≤ 14 kg (Ultrasonic sensor pair)

F1F-P

Gas temperature		-196 °C ... +280 °C
Operating pressure		
	CL150 device flange ¹ :	ATEX/IECEX: 20 bar(g) CSA: 16 bar(g)
	PN25 device flange (optional) ¹ :	ATEX/IECEX: 20 bar(g) CSA: 16 bar(g)
	CL300 device flange (optional) ¹ :	ATEX/IECEX: 20 bar(g) CSA: 16 bar(g)
		¹ Temperature dependent. For details, see section Application ranges.
Ex-approvals		
	IECEX	Ex db [ia Ga] IIA T4 Ga/Gb Ex db [ia Ga] IIB T4 Ga/Gb Ex db [ia Ga] IIC T6 Ga/Gb
	ATEX	II 1/2G Ex db [ia Ga] IIA T4 Ga/Gb II 1/2G Ex db [ia Ga] IIB T4 Ga/Gb II 1/2G Ex db [ia Ga] IIC T6 Ga/Gb
	NEC/CEC (US/CA)	Class I, Division 1, Group D, T4 Class I, Zone 1, Ex/AEx d[ia] IIA, T4 Class I, Division 2, Group D, T4 Class I, Zone 2, Ex/AEx nA[ia] IIA, T4 Class I, Division 1, Groups C and D, T4 Class I, Zone 1, Ex/AEx d[ia] IIB, T4 Class I, Division 2, Groups C and D, T4 Class I, Zone 2, Ex/AEx nA[ia] IIB, T4 Class I, Division 1, Groups B, C and D, T4 Class I, Zone 1, Ex/AEx d[ia] IIB + H2, T4 Class I, Division 2, Groups A, B, C and D, T4 Class I, Zone 2, Ex/AEx nA[ia] IIC, T4
Weight		≤ 10 kg (Ultrasonic sensor pair)

Interface Unit

Description		Unit for controlling the ultrasonic sensors and processing, evaluating and storing measured value data
Ambient temperature		-40 °C ... +60 °C -40 °C ... +65 °C (optional (limited I/O))
Storage temperature		-40 °C ... +70 °C
Ambient pressure		80 kPa ... 110 kPa (0,8 bar .. 1,1 bar)
Ambient humidity		≤ 95 % Relative humidity
Ex-approvals	IECEX	Zone 1: Ex db eb ia IIC T4 Gb

		Zone 1: Ex db ia IIC T4 Gb Zone 2: EX ec ia IIC T4 Gc
	ATEX	Zone 1: II 2G Ex db eb ia IIC T4 Gb Zone 1: II 2G Ex db ia IIC T4 Gb Zone 2: II 3G Ex ec ia IIC T4 Gc
	NEC/CEC (US/CA)	Zone 1: Ex d ia IIC T4 Gb Zone 1: Class I, Zone 1, AEx d ia IIC T4 Gb Zone 1: Class I, Division 1, Groups B, C, D, T4 Zone 2: EX ec ia IIC T4 Gc Zone 2: Class I, Zone 2, AEx ec ia IIC T4 Gc Zone 2: Class I, Division 2, Group A, B, C and D, T4
Enclosure rating		IP66 acc. IEC 60529, Type 4X acc. UL50E
Analog outputs		Up to 6 outputs when using I/O modules (Option) 16 bit: 4 ... 20 mA 7 V DC ... 30 V DC In accordance with NAMUR NE43 Passive, galvanically isolated Reverse polarity protection
Analog inputs		Up to 6 outputs when using I/O modules (option) 24 bit: 4 ... 20 mA 0 ... 5 V DC In accordance with NAMUR NE43 Passive, galvanically isolated Reverse polarity protection
Digital outputs		Switching output: Up to 6 outputs when using I/O module (option) Electrically isolated Max. current: 70 mA Max. switching frequency: 50 Hz Max. input voltage: 30 V DC Max. saturation voltage at output: 0.5 V DC Switchable Namur/open collector Reverse polarity protection Digital output/Frequency output: Up to 12 digital outputs when using I/O modules (option) Electrically isolated Max. current: 50 mA Max. switching frequency: 10 kHz Max. input voltage: 30 V DC Max. saturation voltage at output: 1.8 V DC Switchable Namur/open collector Reverse polarity protection
Digital inputs		Up to 6 with use of I/O modules (Option): Electrically isolated For connecting volt-free contacts or active switching outputs Min. input on voltage 2 V DC Max. input off voltage 2.85 V DC Max. clamping voltage: 30 V DC Reverse voltage protection
Serial		✓ (3)
	Type of fieldbus integration	RS-485
	Data transmission rate	Electrically isolated
Ethernet		✓
	Data transmission rate	10 Mbit/s ... 100 Mbit/s
Modbus		✓
Modbus		

Modbus	Type of fieldbus integration	TCP RTU RS-485 ASCII RS-485
HART	Type of fieldbus integration	✓ HART® master for connecting external pressure and temperature transmitter HART® slave (for communication with control system)
Foundation Fieldbus	Remark	✓ (Option)
	Data transmission rate	Clamping voltage: DC 9 V DC ... 32 V DC Current consumption: 18 mA FOUNDATION fieldbus™ H1, IEC 61158-2 with 31.25 kBit/s ITK 6.3 3 transducer blocks for process measurement variables, counter readings and diagnostic variables 8 AI blocks 1 PID block NAMUR NE 107 compliant
Optical interface	Type of fieldbus integration	✓ Service interface (IR, according to IEC 62056-21)
Indication		LCD: Measurands, system information, maintenance, need for maintenance, alarm
Operation		FLOWgate™ software or control panel on the LCD screen
Dimensions (W x H x D)		For details see dimensional drawings
Weight		Zone 1/Div 1 Ex db version: + 17.5 kg Zone 1 Ex db eb version: + 23 kg Non-Ex/Zone 2: + 8 kg
Electrical connection	Voltage	115 ... 230 V AC / 15 ... 28 V DC
	Frequency	AC variant: 50 ... 60 Hz
	Power consumption	≤ 18 W (AC variant) / ≤ 12 W (DC variant)
Options		Offshore-version, sun and weather protection, tag plate, mounting set 2-inch-pipe installation, infrared-USB adapter, cable glands

Dimensional drawings (Dimensions in mm (inch))

Interface Unit Cl. 1 Div. 2

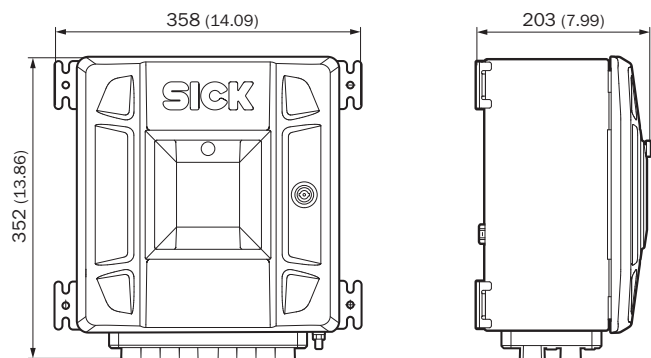

Interface Unit Zone 2

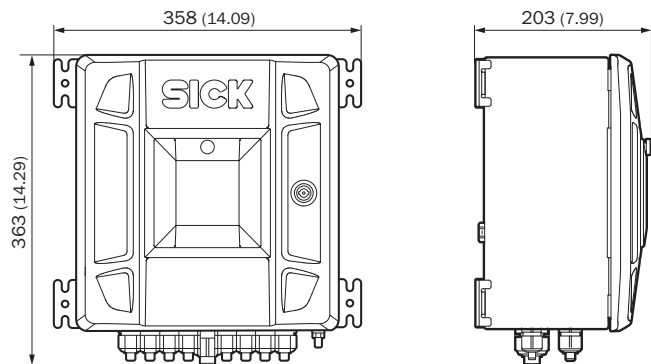

Interface Unit Zone 1 EXDE

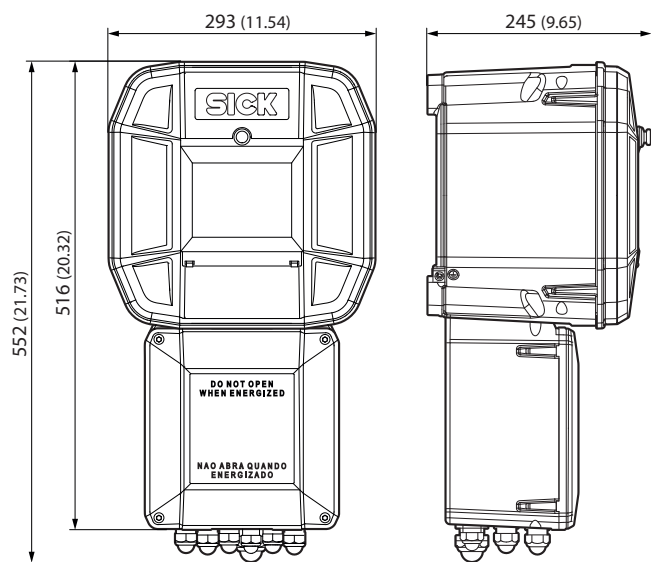

Interface Unit Cl. 1 Div. 1 + Zone 1 EXD

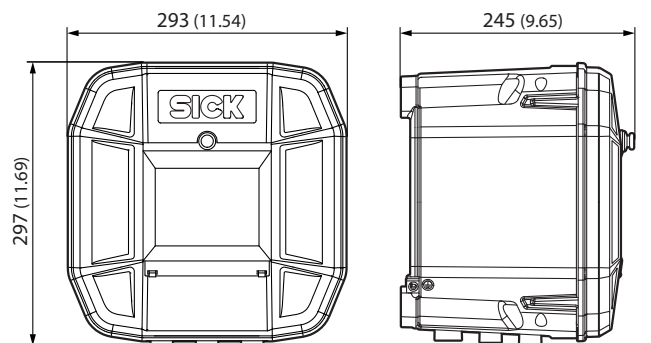

F1F-S/H

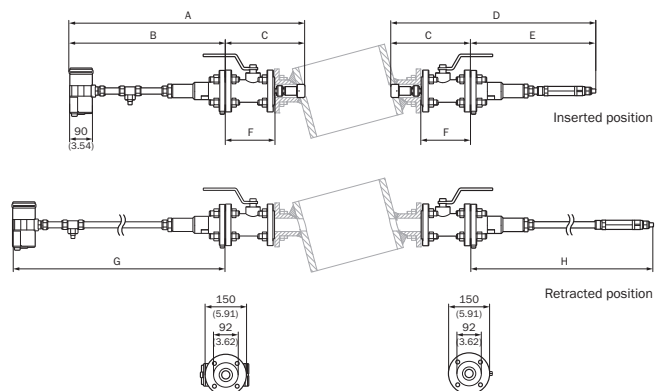

Flare-XT, elongated version	Dimensions							
	A	B	C	D	E	F	G	H
F1F-S	983	583	400	871	471	178	1055.5	944
F1F-H	846	448	398	919	518	178	851	917
Flare-XT, compact version	Dimensions							
	A	B	C	D	E	F	G	H
	F1F-S	883	583	300	771	471	178	955.5
F1F-H	746	448	298	819	518	178	751.5	817
All dimensions in mm.								

F1F-P-M20/-NPT

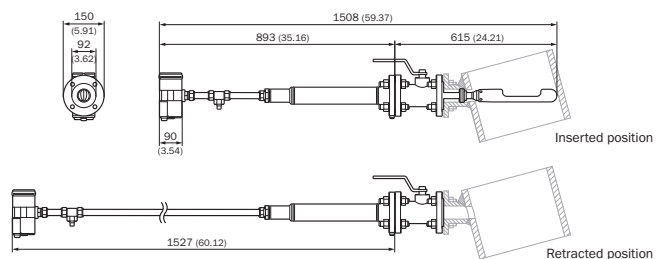

SICK AT A GLANCE

SICK is one of the leading manufacturers of intelligent sensors and sensor solutions for industrial applications. A unique range of products and services creates the perfect basis for controlling processes securely and efficiently, protecting individuals from accidents and preventing damage to the environment.

We have extensive experience in a wide range of industries and understand their processes and requirements. With intelligent sensors, we can deliver exactly what our customers need. In application centers in Europe, Asia and North America, system solutions are tested and optimized in accordance with customer specifications. All this makes us a reliable supplier and development partner.

Comprehensive services complete our offering: SICK LifeTime Services provide support throughout the machine life cycle and ensure safety and productivity.

For us, that is “Sensor Intelligence.”

WORLDWIDE PRESENCE:

Contacts and other locations –www.sick.com