

Micro Motion® Series 3000 Transmitters with MVD™ Technology

Platform architecture designed for flexibility

- Transmitter and/or controller in field-, rack-, or panel-mount design
- Wide range of I/O channels for maximum functionality

Broadest range of application coverage

- Advanced density options enable measurement of concentration, petroleum, net volume, water cut, and associated net oil/water flow
- Provides powerful and easy one-stage or two-stage batch control with ticket printing output
- Delivers effective security capabilities suitable for custody transfer applications

Single operator interface for easy setup, control, and operation

- Full configuration capabilities eliminate the need for external tools
- Large display provides easy-to-read menus and descriptive alarms
- Enables Smart Meter Verification for quick, complete meter diagnosis without process interruption



2200S	2400S	1700 2700	1500 2500	3300 3350	3500 3700	5700
Compact integral 2-wire transmitter	Compact integral transmitter	Versatile field-mount transmitter	Compact control-room transmitter	Frequency-input discrete controller	Integrated control and measurement platform	Advanced field-mount transmitter

Micro Motion® Series 3000 transmitters

Series 3000 transmitters electronics combine transmitter functions and PLC capabilities in one instrument. Series 3000 models feature MVD™ technology, enabling high-speed digital signal processing (DSP) capabilities and a broad range of specialty applications.

MVD technology makes your Micro Motion meter work smarter

- Front end signal processing gives faster response time and dramatically reduces signal noise
- Provides reduced wiring costs through use of standard 4 wire instrument cable
- On-board signal processing results in the cleanest, most accurate signal delivered, even with tough measurement conditions such as entrained gas

Smart Meter Verification: advanced diagnostics for your entire system

- A comprehensive test that can be run locally or from the control room to provide confidence in your meter functionality and performance
- Verifies that your meter performs as well as the day it was installed, giving you assurance in less than 90 seconds

Mounting and Installation flexibility to fit your exact needs

- Form factors include rugged field mount, rack mount, and panel mount designs
- Local User Interfaces provide detailed operator feedback and accessibility
- Connection to new or existing Micro Motion sensors easily achieved through flexible configurations

Control and Application Tailored Software

- 3500 and 3700 transmitters Measure and Control based on direct input from a Micro Motion Coriolis Meter
- 3300 and 3350 models Control based on a frequency input from a remote transmitter
- Specialty application software available such as batch control, petroleum measurement, net oil measurement, and custody transfer security

Table of Contents

Applications	3	Environmental effects	8
Electrical connections	4	Model 3100 accessory specifications	8
Sensor cabling	5	Hazardous area classifications	8
Input signal detail	5	Marine approval classifications	10
Output signal detail	6	Physical specifications	10
Digital communications	7	Dimensions	12
Power supply	7	Ordering Information	16
Environmental limits	8		

Applications

Applications are custom designed programs and software available to offer additional functionality and performance to transmitters. These applications are available through options in the transmitter model code, see the ordering information section for details.

Process monitor/totalizer

Process monitoring and totalizing for multiple variables, including mass flow, volume flow, density, and temperature, reported in the user's choice of unit. Unit options include all common units, plus °API, SCF, beer barrels, etc., and the ability to define a special unit for mass, volume, or gas standard volume.

Smart Meter Verification

Provides a quick, complete assessment of a Micro Motion Coriolis meter, determining whether the meter has been affected by erosion, corrosion, or other influences affecting meter calibration. No secondary references are required to perform this operation, and the meter can continue normal process measurement while the test is in progress.

Discrete batch control

- Configuration of up to six preset batch recipes
- One-stage or two-stage batch control
- End-of-batch warning and batch-overflow alarms
- Automatic overshoot compensation

Weights and measures custody transfer

- Physical and software security
- Security-alarm posting
- Mass or volume totalizer that can be configured by the user
- Compliant with MID 2004/22/EC Annex MI-002 and Annex MI-005
- Certified by NTEP and OIML

Concentration measurement

Provides concentration measurement based on either industry-specific or liquid-specific units and relationships. Standard measurement options include:

- Industry-specific:
 - °Brix
 - °Plato
 - °Balling
 - °Baumé at SG60/60
 - Specific gravity
- Liquid-specific:
 - %HFCS
 - Concentration derived from reference density
 - Concentration derived from specific gravity

Additionally, the application can be customized for site-specific concentration measurement (such as %HNO₃, %NaOH).

Petroleum measurement

Adds the following calculations to the standard software:

- Calculates base density (corrected API Gravity) and Ctl (the correction for the effect of temperature on a liquid)
- Calculates gross volume at standard temperature

Calculates flow-weighted average temperature and flow-weighted average observed gravity (flowing density)

Net Oil (NOC)

- Designed for use with two-phase, three-phase, or compact separators
- Supports up to 48 wells, three well tests per well (well test mode), or continuous measurement of one well
- Measures and reports net oil and net water production
- Real-time water cut data based on process density or read from water cut probe
- Optionally reports gas production
- Manages two-phase flow via patented Transient Bubble Remediation Manages two-phase flow via patented Transient Bubble Remediation (TBR) and Transient Mist Remediation (TMR)
- Enables recalculation of stored NOC data for different reference values

Electrical connections

Connection type	Model 3300/3500 rack-mount	Model 3300/3500 panel-mount	Model 3350/3700 remote field-mount
Input/Output	<ul style="list-style-type: none"> ■ Type D connectors per DIN standard 41612 (IEC 603-2) ■ Solder tails (standard) ■ Screw terminals (optional); accept wire 24 to 16 AWG (0.25 to 1.5 mm²) 	<ul style="list-style-type: none"> ■ Screw terminals (standard); accept wire 24 to 16 AWG (0.25 to 1.5 mm²) ■ I/O cable with remote DIN rail-mount screw terminals (optional) – attach to any of four rail types. I/O cable is available in lengths of 2, 5 and 10 feet (0.6, 1.5, and 3 meters) 	<p>Two color-coded wiring compartments:</p> <ul style="list-style-type: none"> ■ Compartment with intrinsically safe terminals has two 3/4-inch NPT or M20 × 1.5 conduit openings ■ Compartment with non-intrinsically safe terminals has three 3/4-inch NPT or M20 × 1.5 conduit openings ■ Screw terminals accept wire 22 to 16 AWG (0.34 to 1.5 mm²)
Power	<ul style="list-style-type: none"> ■ Screw terminals are fixed to rack chassis ■ Ground makes first and breaks last 	<ul style="list-style-type: none"> ■ Screw terminals 	<ul style="list-style-type: none"> ■ Screw terminals
All power supply screw terminals accept wire 22 to 16 AWG (0.34 to 1.5 mm ²)			
Service port	Two clips for temporary connection to the service port		One pair of terminals supports Modbus/RS-485 signal or service port mode. On device power-up, user has 10 seconds to connect in service port mode. After 10 seconds, the terminals default to Modbus/RS-485 mode.

Sensor cabling

Specification	Value		
Requirements Applies to Model 3500/3700 only. Sensor cabling not applicable to Models 3300/3350.	With sensor interface code 5 <ul style="list-style-type: none"> Requires standard 4-wire twisted-pair signal cable between the sensor and the transmitter. Micro Motion recommends using Micro Motion 4-wire cable. 		
	With Sensor interface code 6 <ul style="list-style-type: none"> Requires standard 4-wire twisted-pair shielded signal cable between the transmitter and the remote core processor. Micro Motion recommends using Micro Motion 4-wire cable. Requires Micro Motion 9-wire signal cable between the remote core processor and the sensor. 		
	Depending on the order, 10 ft (3 m) of 4-wire cable or 10 ft (3 m) of both 4-wire and 9-wire cable are shipped with the order. For longer cable lengths, contact Micro Motion.		
Maximum cable lengths between sensor and transmitter	Cable type	Wire gauge	Maximum length
	<ul style="list-style-type: none"> Micro Motion 4-wire 	Not applicable	<ul style="list-style-type: none"> 1000 ft (300 m) without Ex-approval 500 ft (150 m) with IIC rated sensors 1000 ft (300 m) with IIB rated sensors
	<ul style="list-style-type: none"> Micro Motion 9-wire 	Not applicable	60 ft (20 m)
	<ul style="list-style-type: none"> User-supplied 4-wire: 	VDC 22 AWG (0.35 mm ²)	300 ft (90 m)
		VDC 20 AWG (0.5 mm ²)	500 feet (150 m)
VDC 18 AWG (0.8 mm ²)		1000 feet (300 m)	
RS-485 22 AWG (0.35 mm ²) or larger		1000 feet (300 m)	

Input signal detail

Input	Description
One 2-wire frequency/pulse input	<ul style="list-style-type: none"> Not intrinsically safe Frequency range: 0–20,00 Hz Minimum pulse width: 25 μ-sec Power: Sourcing or sinking Voltage: 0–0.8 VDC low state; 3–30 VDC high state Current: Nominal 5 mA pull-up
Two discrete momentary inputs	<ul style="list-style-type: none"> Not intrinsically safe Pulse width: 0.15 sec minimum Voltage: 0–0.8 VDC low state; 3–30 VDC high state Dry contacts
One 4-wire Coriolis sensor signal input with ground	<ul style="list-style-type: none"> Intrinsically safe

Output signal detail

Output	Description
Two active 4–20 mA outputs	<ul style="list-style-type: none"> ■ Isolated to ± 50 VDC from all other outputs and earth ground ■ Maximum load limit: 100 ohms ■ Output is linear with process from 3.8 to 20.5 mA per NAMUR NE43 (February 2003)
Three discrete outputs	<ul style="list-style-type: none"> ■ Not intrinsically safe ■ Configurable for the application ■ Polarity: Active high or active low, software selectable ■ Power: Internal pull-up to 24 V ■ Current: Sourcing at 5.6 mA when $V_{out} = VDC$; Sinking up to 500 mA at 30 VDC maximum
One 2-wire frequency/pulse output	<ul style="list-style-type: none"> ■ Not intrinsically safe ■ Scalable to 10,000 Hz ■ Output is linear with flow rate to 2,500 Hz ■ Pulse width: 50% duty cycle above the crossover frequency⁽¹⁾; configurable between 0.543 ms and 277 ms ■ Polarity: Active high or active low, software selectable ■ Power: Active or passive, software selectable ■ Voltage: 24 VDC nominal, active; 30 VDC applied maximum, passive ■ Current: Sourcing at 10 mA at 3 VDC, active; Sinking at 500 mA, active or passive
Fault actions	
When a fault is detected, outputs go to configured states. User can select upscale, downscale, internal zero, or none. Milliamp outputs conform to NAMUR NE43 (February 2003).	
Upscale	<ul style="list-style-type: none"> ■ Milliamp: 21 to 24 mA, user configurable ■ Frequency: 15,000 Hz
Downscale	<ul style="list-style-type: none"> ■ Milliamp: 1 to 3.6 mA, user configurable ■ Frequency: 0 Hz
Internal zero	<ul style="list-style-type: none"> ■ Drives the mA and frequency
None	<ul style="list-style-type: none"> ■ Ignores fault conditions

(1) The crossover frequency depends on the configured value of the pulse width. At the minimum pulse width value of 0.543 ms, the crossover frequency is 922 Hz. At the maximum pulse width value of 277 ms, the crossover frequency is 1.8 Hz.

Digital communications

Communication type	Description
RS-485	One pair of terminals supports Service Port (SP) mode or RS-485 mode. In RS-485 mode the port can be used for Modbus/HART communication or as a printer port. On device power-up, the user has 10 seconds to connect in SP mode. After 10 seconds, the terminals switch to RS-485 mode.
	Service port mode <ul style="list-style-type: none"> ■ Protocol: Modbus RTU ■ Data rate: 38,400 baud ■ Parity: no parity ■ Stop bit: one stop bit ■ Address: 111
	RS-485 for Modbus/HART protocols <p>The transmitter can communicate via Modbus RTU, Modbus ASCII, or HART⁽¹⁾ protocols. The communication parameters are configurable with ProLink III software, Modbus, or the display. The shipped default parameters are:</p> <ul style="list-style-type: none"> ■ Data rate: 9600 baud ■ Parity: odd ■ Stop bit: one stop bit
	RS-485 for printer port <p>When the RS-485 port is configured as a printer port, it cannot be used for any other function.</p> <ul style="list-style-type: none"> ■ Requires external RS-232 adapter (not included) ■ With Epson TM-U295 ticket printer, detects and reports “paper out” conditions ■ Is approved for use in custody transfer applications
HART Bell 202 ⁽¹⁾	<p>The HART Bell 202 signal is superimposed on the primary mA output, and is available for host system interface or for polling external measurement devices. The HART Bell 202 communication parameters are:</p> <ul style="list-style-type: none"> ■ Frequency: 1.2 and 2.2 KHz ■ Amplitude: 0.8 mA peak-to-peak ■ Data rate: 1200 baud ■ Resistance: Loop requires 250 to 600 ohms resistance

(1) HART protocol supports configuration of basic transmitter functionality, configuration of the petroleum measurement application, and reading/writing batch setpoints and totals. HART protocol does not support configuration of the batch, concentration measurement, or NOC applications. Both Modbus and the display provide configuration and control of all transmitter functionality.

Power supply

Type	Description
AC power supply	<ul style="list-style-type: none"> ■ 85 to 265 VAC ■ 8 watts typical, 15 watts maximum ■ IEC 60127-3 fuse, 0.63 A time-delay ■ Complies with low voltage directive 2006/95/EC per EN 61010-1 (IEC 61010-1) with amendment 2; Installation (Overvoltage) Category II, Pollution Degree 2
DC power supply	<ul style="list-style-type: none"> ■ 18 to 30 VDC ■ 8 watts typical, 11 watts maximum ■ IEC 60127-3 fuse, 1.6 A time-delay ■ The user-supplied power conductors must be appropriately sized to provide 18 VDC minimum at the power terminals at a load current of 0.7 A.

Environmental limits

Environmental factor		°F	°C
Ambient temperature limits	Operating	-4 to +140	-20 to +60
	Storage	-40 to +158	-40 to +70
Humidity limits	5 to 95% relative humidity, non-condensing at 140 °F (60 °C)		
Vibration limits	Meets IEC 60068-2-6, endurance sweep, 5 to 2000 Hz, 50 sweep cycles at 1.0 g		
Housing rating	Model 3350/3700	NEMA 4X (CSA) and IP66/IP67 (ATEX/IECEx)	
	Model 3300/3500	At least IP20	

Environmental effects

EMI effects

- Complies with EMC directive 2004/108/EC per EN 61326 Industrial
- Complies with NAMUR NE-21 (22.08.2007)

Ambient temperature effect

On analog outputs: $\pm 0.005\%$ of span per °C change from temperature at which the outputs were trimmed

Model 3100 accessory specifications

Relays module:

- Three relays
- Solid state, SPST
- Rated at 24–250 VAC, 40 mA to 5 A; or 0–70 VDC, 5 A
- Energized by discrete outputs
- NEMA 4X (IP65) enclosure (optional)

Hazardous area classifications

Model 3300

UL and CSA

- Class I, Div. 2, Groups A, B, C, and D when installed in a suitable enclosure

Model 3350

UL and CSA

- Class I, Div. 2, Groups A, B, C, and D (standard housing)

ATEX

- ATEX Zone 1

CE 0575  II 2G Ex de [ib] IIB/IIC T4 Gb

IECEX

- IECEX Zone 1
Ex de [ib] IIB/IIC T4 Gb

Model 3500

UL and CSA

- Class I, Div. 2, Groups A, B, C, and D when installed in a suitable enclosure
Provides non-incendive sensor outputs for use in Class I, Div. 2, Groups A, B, C, and D, or intrinsically safe sensor outputs for use in Class I, Div. 1, Groups C and D; Class II, Div. 1, Groups E, F, and G

ATEX

- Safe area only. Marked as CE 0575  II (2) G [Ex ib] IIB/IIC, can be connected to a sensor in Zone 1 area if sensor is marked as Ex ib IIB/IIC.

Model 3700

UL and CSA

- Class I, Div. 2, Groups A, B, C, and D
Provides non-incendive sensor outputs for use in Class I, Div. 2, Groups A, B, C, and D, or intrinsically safe sensor outputs for use in Class I, Div. 1, Groups C and D; Class II, Div. 1, Groups E, F, and G.

ATEX

- ATEX Zone 1

CE 0575  II 2G Ex de [ib] IIB/IIC T4 Gb

IECEX

- IECEX Zone 1
Ex de [ib] IIB/IIC T4 Gb

Model 3100 Accessory (relays module)

UL and CSA

- Class I, Div. 2, Groups A, B, C, and D

Marine approval classifications

For Model 3700 only.

Marine approval	Country
Lloyds Register ENV1, ENV2, ENV3, ENV5	United Kingdom
Det Norske Veritas- Germanischer Lloyd	Norway-Germany
Bureau Veritas	France
American Bureau of Shipping	USA
Nippon Kaiji Kyokai	Japan

Physical specifications

Model 3300/3500 rack or panel mount

Specification	Value
Housing	<p>Rack</p> <ul style="list-style-type: none"> ■ 19-inch (486.2 mm) rack-mount housing meets DIN standard 41494 and IEC 297-3 ■ Front panel is rated IP40. Front panel is aluminum with laminate overlay <p>Panel</p> <ul style="list-style-type: none"> ■ Front panel with bezel is rated NEMA 4X (IP65) Front panel is aluminum with laminate overlay
Weight	<ul style="list-style-type: none"> ■ Maximum 3.5 lb (1.6 kg), excluding prepared cables
Interface/display	<p>Display</p> <ul style="list-style-type: none"> ■ Backlit LCD, 128 x 128 pixel, bit map ■ Adjustable contrast ■ Non-glare, chemical-resistant acrylic lens <p>Interface (keypad membrane switch)</p> <ul style="list-style-type: none"> ■ Large push buttons with tactile feedback ■ Software-defined function keys ■ Chemical-resistant polyester

Model 3350 and 3700 remote field mount

Specification	Value
Housing	<ul style="list-style-type: none"> ■ Housing is epoxy painted aluminum, bracket is 304 SS ■ NEMA 4X (CSA) and IP66/IP67 (ATEX/IECEX)
Weight	<ul style="list-style-type: none"> ■ 19 lb (8.6 kg)
Terminal compartments	<p>Compartment with threaded cover contains electronics.</p> <p>Terminal compartment contains:</p> <ul style="list-style-type: none"> ■ Non-intrinsically safe compartment with input/output and power supply terminals ■ Intrinsically safe compartment with interface/display, sensor terminals (Model 3700 only), and optional input and output terminals
Mounting	<ul style="list-style-type: none"> ■ Mounting bracket and interface/display rotate to allow mounting in four different orientations
Interface/display	<p>Display</p> <ul style="list-style-type: none"> ■ Backlit LCD, 128 x 128 pixel, bit map ■ Adjustable contrast ■ Non-glare, tempered glass lens ■ Suitable for hazardous area installation <p>Interface (keypad membrane switch)</p> <ul style="list-style-type: none"> ■ Large push buttons with tactile feedback ■ Software-defined function keys ■ Chemical-resistant polyester

Dimensions

Rack-mount Model 3300/3500

Dimensions in inches (mm)

1 U = 1 HE = 1.750 inches (44.45 mm)
 1 HP = 1 TE = 0.200 inches (5.08 mm)

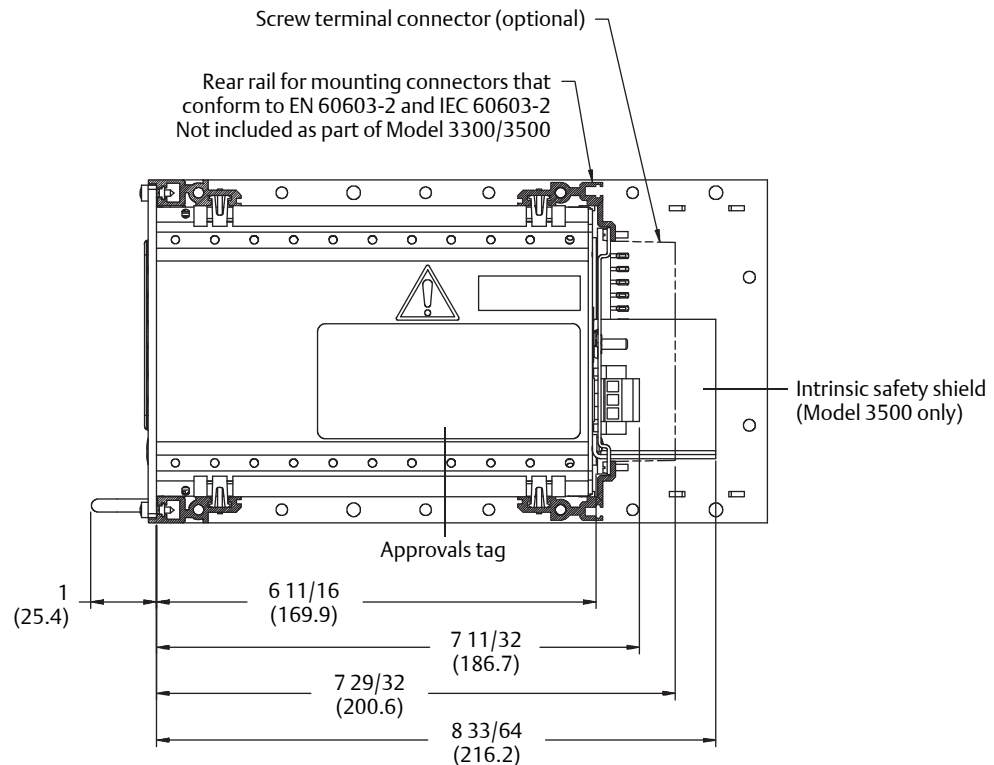
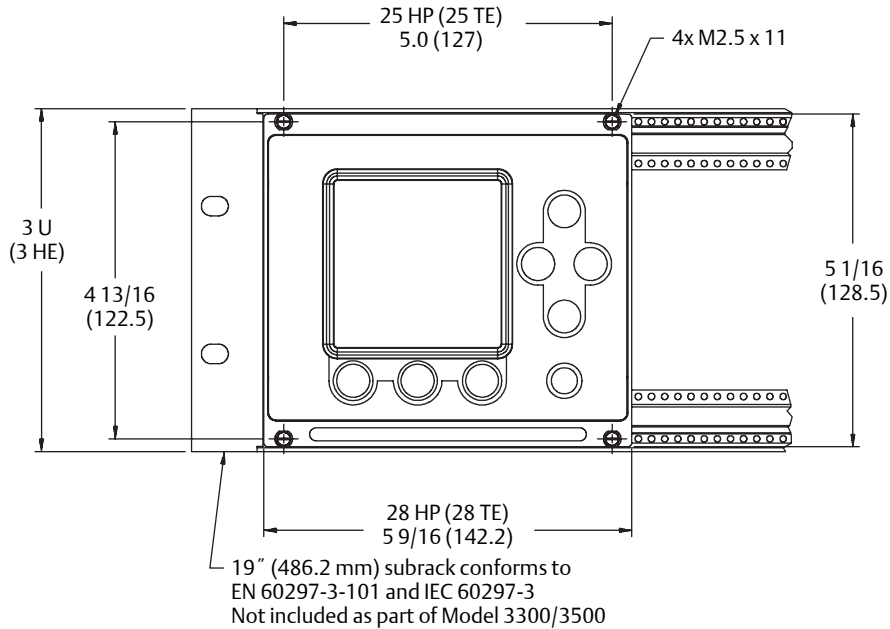

Panel mount Model 3300/3500 with screw-type connectors

Dimensions in inches (mm)

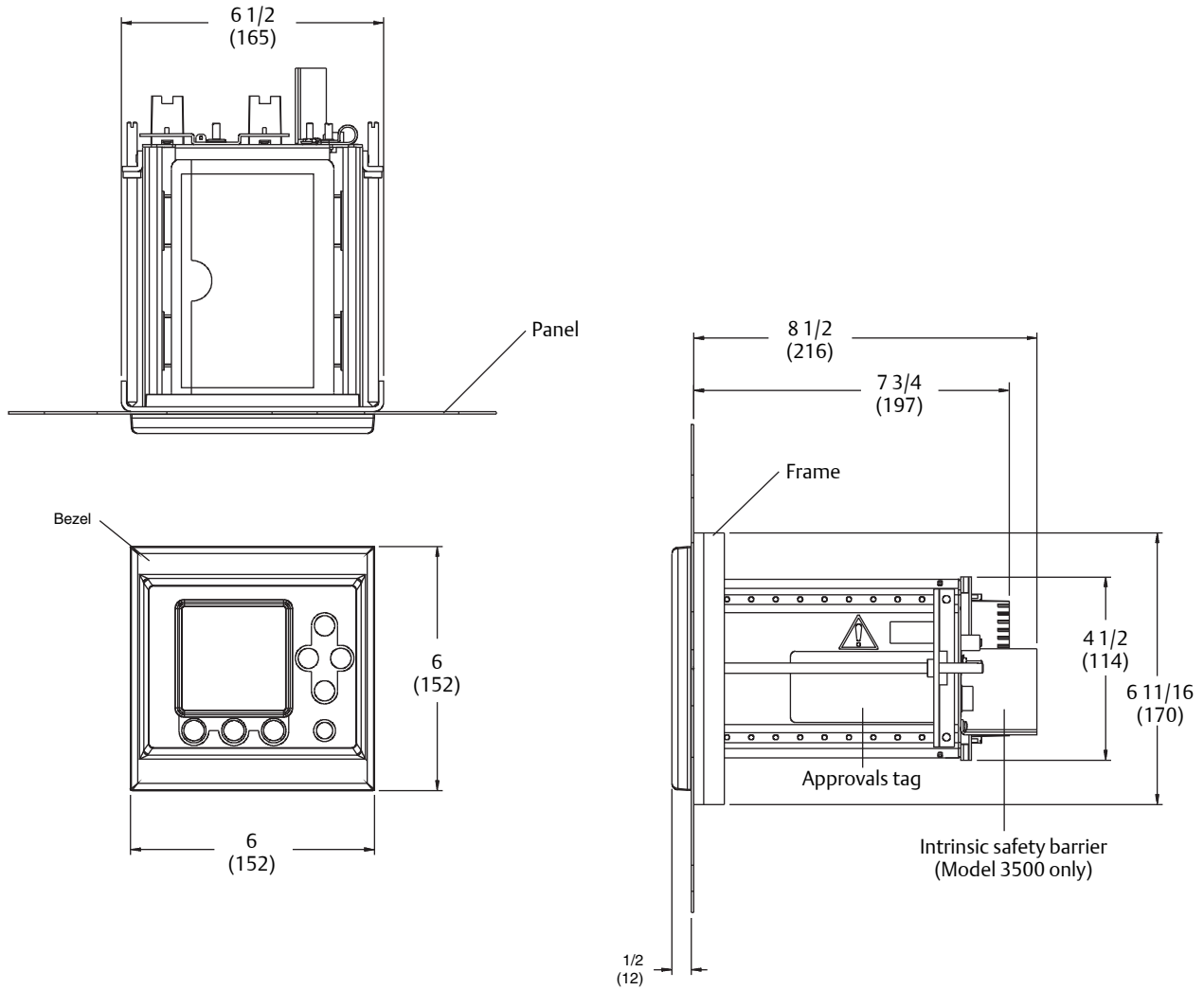

Panel-mount Model 3300/3500 with optional I/O cable

Dimensions in inches (mm)

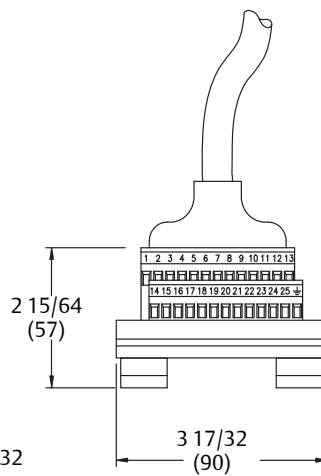
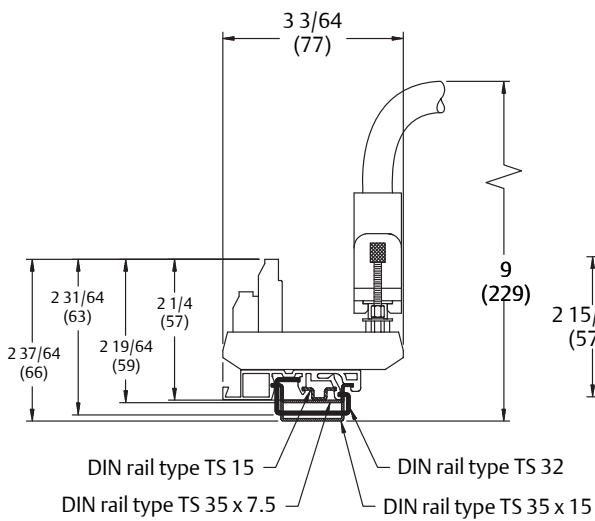
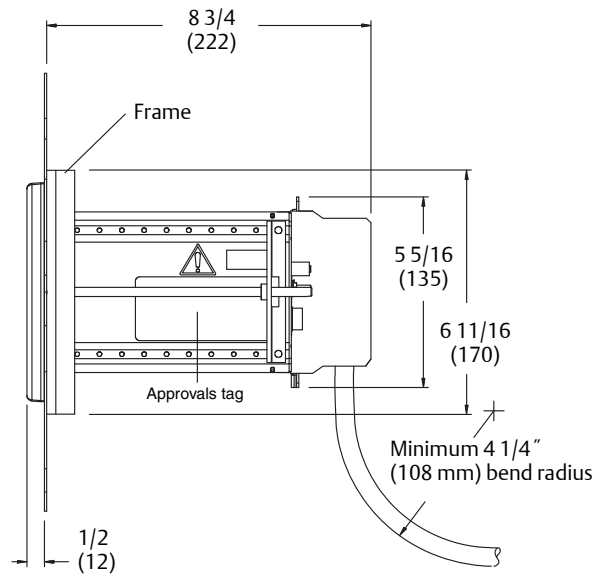
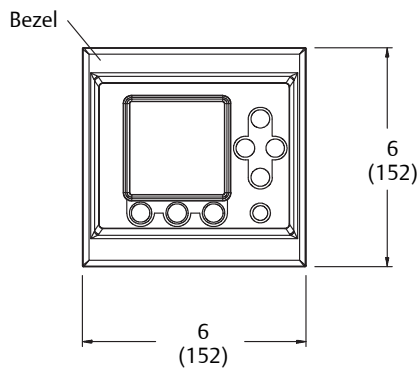
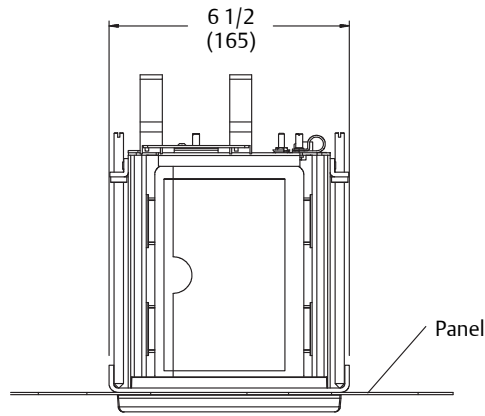

DIN-rail-mount screw terminals detail

Field-mount Model 3350/3700

Dimensions in inches (mm)

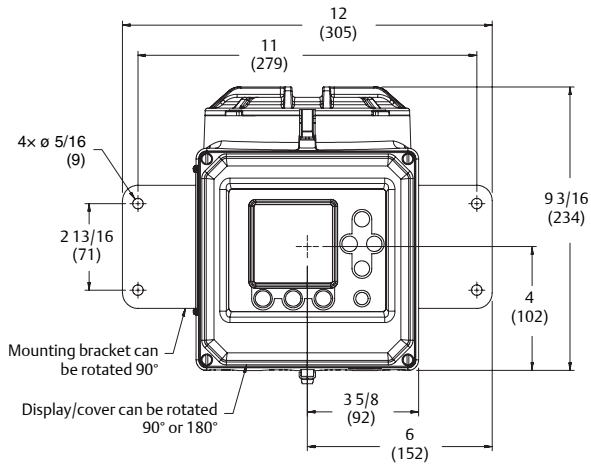

4x M8 x 16 bolts are included for attaching the mounting bracket to the Model 3350 or 3700 transmitter

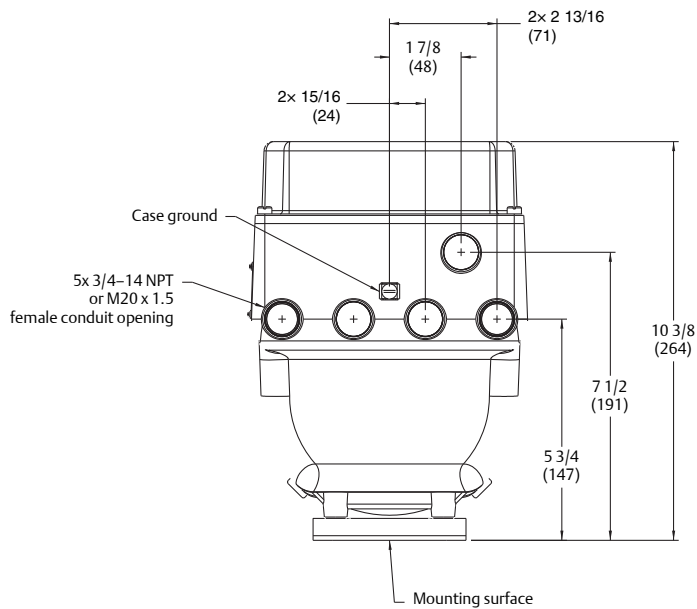
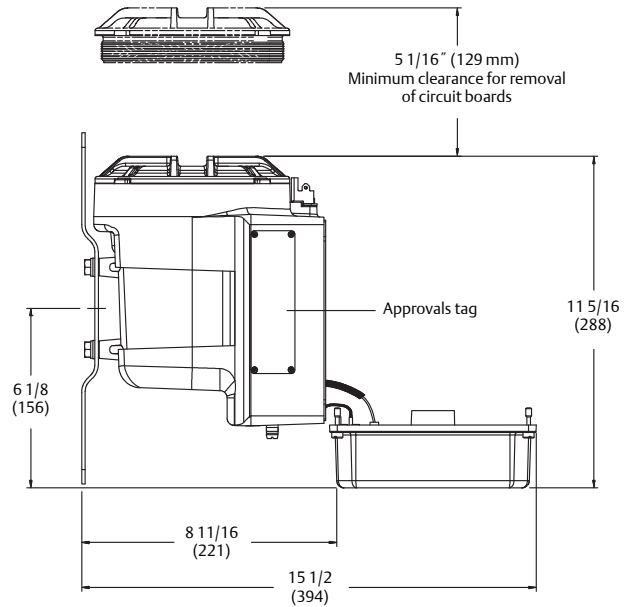

Conduit openings view

Ordering Information

Model 3300

Product code structure for Model 3300

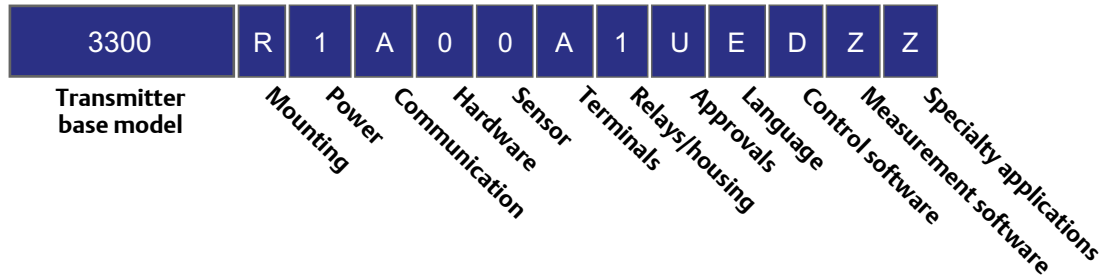

Base model

Model	Product description
3300	Micro Motion Coriolis Discrete Controller; remote rack/panel-mount

Mounting

Code	Mounting options for Model 3300
R	DIN rack
P	Panel-mount

Power

Code	Power supply options for Model 3300
1	85 to 265 VAC
2	18 to 30 VDC (recommended for 24 VDC users)

Communication

Code	Communication gateway modules for Model 3300
A	No communication gateway module

Hardware

Code	Additional hardware modules for Model 3300
0	No additional hardware modules
1	Weights & Measures Custody Transfer (all other than OIML); Control Application code must be code D (Discrete Batch Controller)

Sensor

Code	Sensor interface for Model 3300
0	No sensor interface

Terminals

Code	Terminal options for Model 3300
B	Screw terminals
C	Prepared cables; 2 foot (0.6 m) length; use with mounting code P only
D	Prepared cables; 5 foot (1.5 m) length; use with mounting code P only
E	Prepared cables; 10 foot (3 m) length; use with mounting code P only

Relays and housings

Code	Relays and housing options for Model 3300
1	No relays and housing

Approvals

Code	Terminal options for Model 3300
M	Micro Motion standard (no approval)
U	UL
C	CSA (Canada only)
A	CSA C-US (U.S.A. and Canada)

Language

Code	Display and documentation language for Model 3300		
A	English local display	Danish quick reference guide	English manual
D	English local display	Dutch quick reference guide	English manual
E	English local display	English quick reference guide	English manual
F	French local display	French quick reference guide	French manual
G	German local display	German quick reference guide	German manual
H	English local display	Finnish quick reference guide	English manual
I	English local display	Italian quick reference guide	English manual
J	Japanese local display	Japanese quick reference guide	English manual
M	English local display	Chinese quick reference guide	Chinese manual
N	English local display	Norwegian quick reference guide	English manual
O	English local display	Polish quick reference guide	English manual
P	English local display	Portuguese quick reference guide	English manual
S	English local display	Spanish quick reference guide	Spanish manual
W	English local display	Swedish quick reference guide	English manual
B	English local display	Hungarian CE requirements document	English manual and quick reference guide
C	English local display	Czech CE requirements document	English manual and quick reference guide
K	English local display	Slovak CE requirements document	English manual and quick reference guide
L	English local display	Latvian CE requirements document	English manual and quick reference guide
T	English local display	Estonian CE requirements document	English manual and quick reference guide
U	English local display	Greek CE requirements document	English manual and quick reference guide
V	English local display	Lithuanian CE requirements document	English manual and quick reference guide
Y	English local display	Slovenian CE requirements document	English manual and quick reference guide

Control software

Code	Control application software for Model 3300
Z	Process monitor/totalizer (standard)
D	Discrete batch controller

Measurement software

Code	Measurement application software for Model 3300
Z	No measurement application software

Specialty applications

Code	Specialty applications for Model 3300
Z	No specialty applications
X	ETO application

Model 3350

Product code structure for Model 3350

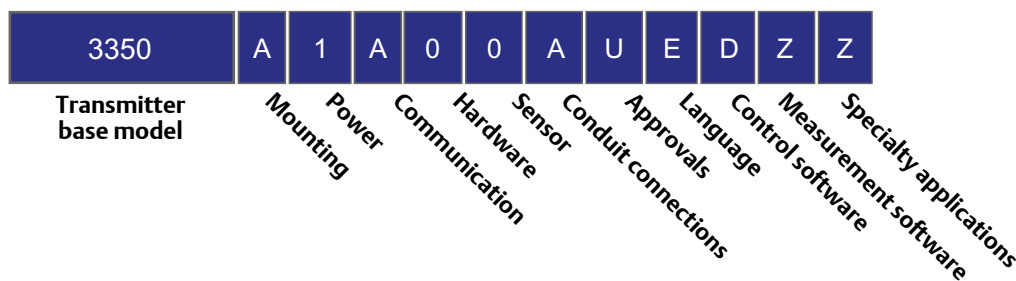

Base model

Model	Product description
3350	Micro Motion Coriolis Discrete Controller; remote field-mount

Mounting

Code	Mounting options for Model 3350
A	Field-mount

Power

Code	Power supply options for Model 3350
1	85 to 265 VAC
2	18 to 30 VDC (recommended for 24 VDC users)

Communication

Code	Communication gateway module for Model 3350
A	No communication gateway module

Hardware

Code	Additional hardware modules for Model 3350
0	No additional hardware modules
1	Weights & Measures Custody Transfer (all other than OIML); Control Application code must be code D (Discrete Batch Controller)

Sensor

Code	Sensor interface for Model 3350
0	No sensor interface

Conduit connections

Code	Conduit connection options for Model 3350
A	M20 without glands
B	M20 with three increased safety glands
C	M20 with five increased safety glands
D	3/4-inch NPT without conduit seals

Approvals

Code	Terminal options for Model 3350
M	Micro Motion standard (no approval)
U	UL
C	CSA (Canada only)
A	CSA C-US (U.S.A. and Canada)
I	IECEX EPL Gb, Ex de, Zone 1
Z	ATEX II 2G, Ex de, Zone 1
P	NEPSI – Safe area; only available with language code M (Chinese)

Language

Code	Display and documentation language for Model 3350		
A	English local display	Danish quick reference guide	English manual
D	English local display	Dutch quick reference guide	English manual
E	English local display	English quick reference guide	English manual
F	French local display	French quick reference guide	French manual
G	German local display	German quick reference guide	German manual
H	English local display	Finnish quick reference guide	English manual
I	English local display	Italian quick reference guide	English manual
J	Japanese local display	Japanese quick reference guide	English manual
M	English local display	Chinese quick reference guide	Chinese manual
N	English local display	Norwegian quick reference guide	English manual
O	English local display	Polish quick reference guide	English manual
P	English local display	Portuguese quick reference guide	English manual

Code	Display and documentation language for Model 3350		
S	English local display	Spanish quick reference guide	Spanish manual
W	English local display	Swedish quick reference guide	English manual
B	English local display	Hungarian CE requirements document	English manual and quick reference guide
C	English local display	Czech CE requirements document	English manual and quick reference guide
K	English local display	Slovak CE requirements document	English manual and quick reference guide
L	English local display	Latvian CE requirements document	English manual and quick reference guide
T	English local display	Estonian CE requirements document	English manual and quick reference guide
U	English local display	Greek CE requirements document	English manual and quick reference guide
V	English local display	Lithuanian CE requirements document	English manual and quick reference guide
Y	English local display	Slovenian CE requirements document	English manual and quick reference guide

Control software

Code	Control application software for Model 3350
Z	Process monitor/totalizer (standard)
D	Discrete batch controller

Measurement software

Code	Measurement application software for Model 3350
Z	No measurement application software

Specialty applications

Code	Specialty applications for Model 3350
Z	No specialty applications
X	ETO application

Model 3500

Product code structure for Model 3500

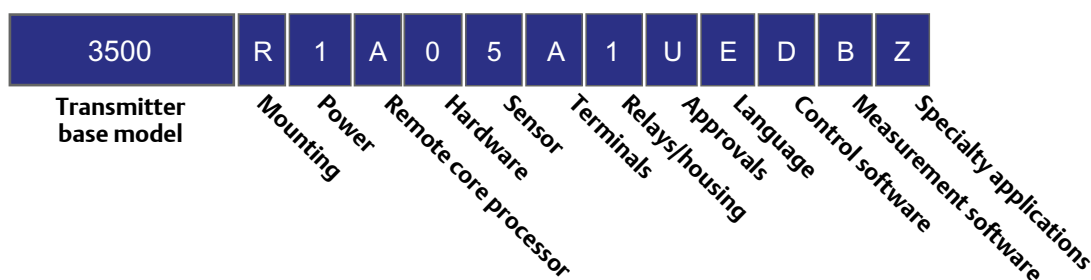

Base model

Model	Product description
3500	Micro Motion Coriolis multivariable transmitter and discrete controller; remote rack/panel-mount

Mounting

Code	Mounting options for Model 3500
R	DIN rack
P	Panel-mount

Power

Code	Power supply options for Model 3500
1	85 to 265 VAC
2	18 to 30 VDC (recommended for 24 VDC users)

Remote core processor

Code	Remote core processor options for Model 3500
	With sensor interface code 5
A	None
	With sensor interface code 6 (remote core processor)
B	1/2"–NPT remote core processor – no gland
E	M20 remote core processor – no gland
F	Remote core processor – brass/nickel cable gland
G	Remote core processor – stainless steel cable gland

Hardware

Code	Additional hardware modules for Model 3500
0	No additional hardware modules
1	Weights & Measures Custody Transfer (all other than OIML); Control Application code must be code D (Discrete Batch Controller)
2	Weights & Measures Custody Transfer (OIML); MID 2004/22/EC compliant, based on OIML R117-1 and OIML R137-1; Evaluation Certificate TC7057

Sensor

Code	Sensor interface for Model 3500
5	4-wire interface to sensors with core processors
6	4-wire remote mount transmitter with 9-wire remote core processor to sensors with junction box
7	4-wire remote mount transmitter with 9-wire remote enhanced core processor to sensors with junction box

Terminals

Code	Terminal options for Model 3500
B	Screw terminals
C	Prepared cables; 2 foot (0.6 m) length (use with mounting code P only)
D	Prepared cables; 5 foot (1.5 m) length (use with mounting code P only)
E	Prepared cables; 10 foot (3 m) length (use with mounting code P only)

Relays and housings

Code	Relays and housing options for Model 3300
1	No relays and housing

Approvals

Code	Terminal options for Model 3500
M	Micro Motion standard (no approval)
U	UL
C	CSA (Canada only)
A	CSA C-US (U.S.A. and Canada)
Z	ATEX II (2) G [Ex ib] IIB/IIC
P	NEPSI – Safe area; only available with language code M (Chinese)

Language

Code	Display and documentation language for Model 3500		
A	English local display	Danish quick reference guide	English manual
D	English local display	Dutch quick reference guide	English manual
E	English local display	English quick reference guide	English manual
F	French local display	French quick reference guide	French manual
G	German local display	German quick reference guide	German manual
H	English local display	Finnish quick reference guide	English manual
I	English local display	Italian quick reference guide	English manual
J	Japanese local display	Japanese quick reference guide	English manual
M	English local display	Chinese quick reference guide	Chinese manual
N	English local display	Norwegian quick reference guide	English manual
O	English local display	Polish quick reference guide	English manual
P	English local display	Portuguese quick reference guide	English manual
S	English local display	Spanish quick reference guide	Spanish manual
W	English local display	Swedish quick reference guide	English manual
B	English local display	Hungarian CE requirements document	English manual and quick reference guide
C	English local display	Czech CE requirements document	English manual and quick reference guide
K	English local display	Slovak CE requirements document	English manual and quick reference guide
L	English local display	Latvian CE requirements document	English manual and quick reference guide
T	English local display	Estonian CE requirements document	English manual and quick reference guide
U	English local display	Greek CE requirements document	English manual and quick reference guide
V	English local display	Lithuanian CE requirements document	English manual and quick reference guide
Y	English local display	Slovenian CE requirements document	English manual and quick reference guide

Control software

Code	Control application software for Model 3500
Z	Process monitor/totalizer (standard)
C	Process monitor/totalizer; with Smart Meter Verification; requires the transmitter to be connected to an enhanced core processor.
D	Discrete batch controller
E	Discrete batch controller; with Smart Meter Verification; requires the transmitter to be connected to an enhanced core processor.

Measurement software

Code	Measurement application software for Model 3500
Z	No measurement application software
G	Concentration measurement
B	Concentration measurement with predefined algorithms for food and beverage
A	Petroleum measurement
N	Net Oil Computer; control software code must be C or Z

Specialty applications

Code	Specialty applications for Model 3500
Z	No specialty applications
X	ETO application

Model 3700

Product code structure for Model 3700

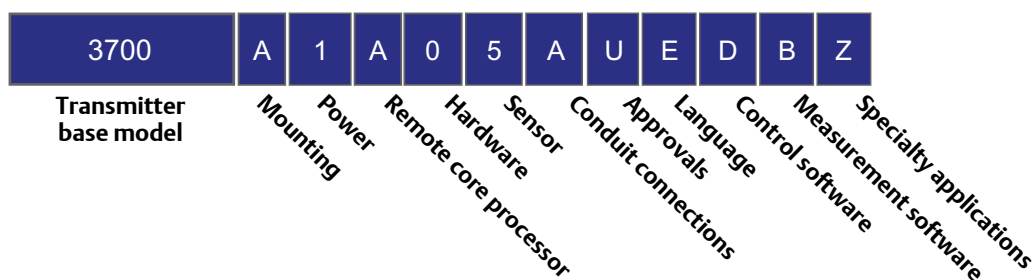

Base model

Model	Product description
3700	Micro Motion Coriolis multivariable transmitter and discrete controller; remote field-mount

Mounting

Code	Mounting options for Model 3700
A	Field mount

Power

Code	Power supply options for Model 3700
1	85 to 265 VAC
2	18 to 30 VDC (recommended for 24 VDC users)

Remote core processor

Code	Remote core processor options for Model 3700
	With sensor interface code 5
A	None
	With sensor interface code 6 (remote core processor)
B	1/2"–NPT remote core processor – no gland
E	M20 remote core processor – no gland
F	Remote core processor – brass/nickel cable gland
G	Remote core processor – stainless steel cable gland

Hardware

Code	Additional hardware modules for Model 3700
0	No additional hardware modules
1	Weights & Measures Custody Transfer (all other than OIML); Control Application code must be code D (Discrete Batch Controller)
2	Weights & Measures Custody Transfer (OIML); MID 2004/22/EC compliant, based on OIML R117-1 and OIML R137-1; Evaluation Certificate TC7057

Sensor

Code	Sensor interface for Model 3700
5	4-wire interface to sensors with core processors
6	4-wire remote mount transmitter with 9-wire remote core processor to sensors with junction box
7	4-wire remote mount transmitter with 9-wire remote enhanced core processor to sensors with junction box

Conduit connections

Code	Conduit connection options for Model 3700
A	M20 without glands
B	M20 with three increased safety glands
C	M20 with five increased safety glands
D	3/4-inch NPT without conduit seals
S ⁽¹⁾	Japan - with three 1/2G brass nickel cable glands
T ⁽¹⁾	Japan - with five 1/2G brass nickel cable glands
U ⁽¹⁾	Japan - with three 1/2G stainless steel cable glands
V ⁽¹⁾	Japan - with five 1/2G stainless steel cable glands

(1) Only available with Approval code M. Not available for quotes outside of Japan.

Approvals

Code	Terminal options for Model 3700
M	Micro Motion standard (no approval)
U	UL
C	CSA (Canada only)
A	CSA C-US (U.S.A. and Canada)
I	IECEX EPL Gb, Ex de [ib], Zone 1
Z	ATEX II 2 G, Ex de [ib], Zone 1
P	NEPSI – Safe area; only available with language code M (Chinese)

Language

Code	Display and documentation language for Model 3700		
A	English local display	Danish quick reference guide	English manual
D	English local display	Dutch quick reference guide	English manual
E	English local display	English quick reference guide	English manual
F	French local display	French quick reference guide	French manual
G	German local display	German quick reference guide	German manual
H	English local display	Finnish quick reference guide	English manual
I	English local display	Italian quick reference guide	English manual
J	Japanese local display	Japanese quick reference guide	English manual
M	English local display	Chinese quick reference guide	Chinese manual
N	English local display	Norwegian quick reference guide	English manual
O	English local display	Polish quick reference guide	English manual
P	English local display	Portuguese quick reference guide	English manual
S	English local display	Spanish quick reference guide	Spanish manual
W	English local display	Swedish quick reference guide	English manual
B	English local display	Hungarian CE requirements document	English manual and quick reference guide
C	English local display	Czech CE requirements document	English manual and quick reference guide
K	English local display	Slovak CE requirements document	English manual and quick reference guide
L	English local display	Latvian CE requirements document	English manual and quick reference guide
T	English local display	Estonian CE requirements document	English manual and quick reference guide
U	English local display	Greek CE requirements document	English manual and quick reference guide
V	English local display	Lithuanian CE requirements document	English manual and quick reference guide
Y	English local display	Slovenian CE requirements document	English manual and quick reference guide

Control software

Code	Control application software for Model 3700
Z	Process monitor/totalizer (standard)
C	Process monitor/totalizer; with Smart Meter Verification; requires the transmitter to be connected to an enhanced core processor.
D	Discrete batch controller
E	Discrete batch controller; with Smart Meter Verification; requires the transmitter to be connected to an enhanced core processor.

Measurement software

Code	Measurement application software for Model 3700
Z	No measurement application software
G	Concentration measurement
B	Concentration measurement with predefined algorithms for food and beverage
A	Petroleum measurement
N	Net Oil Computer; control software code must be C or Z

Specialty applications

Code	Specialty applications for Model 3700
Z	No specialty applications
X	ETO application

Add on option

Code	Specialty applications for Model 3700
LR	Lloyd's BV and DNV Approval for Marine (includes necessary hardware)

Model 3100 high energy relay

Product code structure for Model 3100

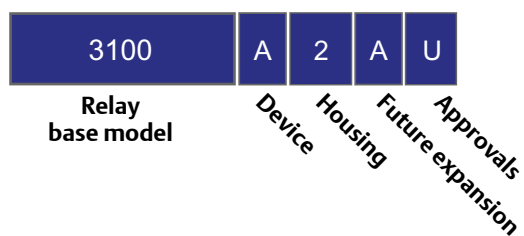

Base model

Model	Product description
3100	Micro Motion Coriolis multivariable transmitter and discrete controller; remote rack/panel-mount

Device (order separately)

Code	Device options for Model 3100
A	3 relays; 24–250 VAC; 5 A
B	3 relays; 0–70 VDC; 5 A

Housing

Code	Housing options for Model 3100
1	No housing
2	NEMA 4X housing for relays only

Future expansion

Code	Future expansion options fro Model 3100
A	Reserved for future use

Approvals

Code	Terminal options for Model 3500
M	Micro Motion standard (no approval)
U	UL Class 1, Div. 2, Groups A, B, C, and D
C	CSA Class 1, Div. 2, Groups A, B, C, and D

Emerson Process Management Americas

7070 Winchester Circle
Boulder, Colorado USA 80301
www.MicroMotion.com
www.Rosemount.com
T: +1 800 522 6277
T: +1 (303) 527 5200
F: +1 (303) 530 8459

Mexico T: 52 55 5809 5300
Argentina T: 54 11 4837 7000
Brazil T: 55 15 3413 8000
Venezuela T: 58 26 1300 8100
Chile T: 56 2 2928 4800

Emerson Process Management Europe/Middle East

Central & Eastern Europe T: +41 41 7686 111
Dubai T: +971 4 811 8100
Abu Dhabi T: +971 2 697 2000
France T: 0800 917 901
Germany T: 0800 182 5347
Italy T: 8008 77334
The Netherlands T: +31 (0) 70 413 6666
Belgium T: +32 2 716 77 11
Spain T: +34 913 586 000
U.K. T: 0870 240 1978
Russia/CIS T: +7 495 981 9811

Emerson Process Management Asia Pacific

Australia T: (61) 3 9721 0200
China T: (86) 21 2892 9000
India T: (91) 22 6662 0566
Japan T: (81) 3 5769 6803
South Korea T: (82) 2 3438 4600
Singapore T: (65) 6 777 8211

© 2016 Micro Motion, Inc. All rights reserved.

The Emerson logo is a trademark and service mark of Emerson Electric Co. Micro Motion, ELITE, ProLink, MVD and MVD Direct Connect marks are marks of one of the Emerson Process Management family of companies. All other marks are property of their respective owners.

Micro Motion supplies this publication for informational purposes only. While every effort has been made to ensure accuracy, this publication is not intended to make performance claims or process recommendations. Micro Motion does not warrant, guarantee, or assume any legal liability for the accuracy, completeness, timeliness, reliability, or usefulness of any information, product, or process described herein. We reserve the right to modify or improve the designs or specifications of our products at any time without notice. For actual product information and recommendations, please contact your local Micro Motion representative.