

Micro Motion® Model 2400S Transmitters with MVD™ Technology

The Model 2400S transmitter provides next-generation MVD technology in a compact, space-saving design. Difficult applications become easy with ultra-fast meter response time, the ability to handle high degrees of air entrainment, and built-in smart diagnostics that alert you to problems before they impact your process.

Integrated architecture designed for easy access to process intelligence

- Provides extensive built-in diagnostics for proactive viewing of process events
- Enables Smart Meter Verification for quick, complete meter diagnosis without process interruption.
- Supports PROFIBUS-DP and DeviceNet™ communication protocols for seamless connectivity

Superior performance in the most challenging applications

- Delivers best two-phase flow capability for batching, loading, and entrained air applications
- Ultra-fast signal processing unlocks unmatched measurement performance



2200S	2400S	1700 2700	1500 2500	3300 3350	3500 3700	5700
Compact integral 2-wire transmitter	Compact integral transmitter	Versatile field-mount transmitter	Compact control-room transmitter	Frequency-input discrete controller	Integrated control and measurement platform	Advanced field-mount transmitter



Micro Motion Model 2400S transmitters

Micro Motion transmitters and controllers from Emerson Process Management utilize MVD technology to deliver accurate, high-speed multivariable signals. Micro Motion transmitters are available with a wide selection of communication protocols, including 4–20 mA, HART®, Foundation™ fieldbus, PROFIBUS, DeviceNet™, Modbus®, and more. That means you will always be able to receive the process information you need in a format that works for your installation. Micro Motion transmitters also carry advanced diagnostic tools, allowing you to rest easy knowing your process is being monitored correctly.

MVD technology

MVD technology makes your Micro Motion flowmeter work smarter. Front-end digital processing dramatically reduces signal noise and gives you faster response time compared to analog devices.

Only MVD technology allows you to:

- Measure multiple variables for accurate process control
- Identify and resolve problems easily with built-in smart diagnostics
- Flexible architecture enables tuning for your application needs
- Upgrade transmitter functionality as needed, without impacting availability

Model 2400S transmitters

The Micro Motion Model 2400S transmitter is leading the way among MVD transmitters. The Model 2400S transmitter provides next-generation performance in an innovative, compact package, integrally mounted on a Micro Motion meter. Difficult applications become easy with ultra-fast meter response time, the ability to handle high degrees of air entrainment, and built-in smart diagnostics that alert you to problems before they impact your process.

The Model 2400S transmitter is available with a range of communication options: analog channels or digital communication with PROFIBUS-DP or DeviceNet protocols.

The Model 2400S raises the bar in process measurement by providing outstanding out-of-the-box performance unequalled by any other manufacturer or technology.

Table of contents

Input/output signal detail	3	Hazardous area classifications	6
Electrical connections	3	Physical specifications	7
Power supply	5	Dimensions	11
Environmental limits	5	Ordering Information	13
Environmental effects	6		

Electrical connections

Connection type	Model 2400S Analog	Model 2400S PROFIBUS-DP	Model 2400S DeviceNet
Input/Output	Two pairs of wiring terminals for transmitter inputs/ outputs. Screw terminals accept solid or stranded conductors, 26 to 14 AWG (0.14 to 2.5 mm ²).		
PROFIBUS-DP segment		One pair of wiring terminals for connection to PROFIBUS-DP segment. Connection type: <ul style="list-style-type: none"> ■ Screw terminals accept solid or stranded conductors, 26 to 14 AWG (0.14 to 2.5 mm²). ■ Five-pin PROFIBUS-DP M12 (Eurofast) female connector (optional). 	
DeviceNet segment			One pre-installed male 5-pin Eurofast connector for I/O and power supply wiring.
Power	One pair of wiring terminals accepts AC or DC power. One internal ground lug for power supply ground wiring. Screw terminals accept solid or stranded conductors, 26 to 14 AWG (0.14 to 2.5 mm ²).	One pair of wiring terminals accepts AC or DC power. One internal ground lug for power supply ground wiring. Screw terminals accept solid or stranded conductors, 26 to 14 AWG (0.14 to 2.5 mm ²).	
Service port	Two clips for temporary connection to the service port. Two clips for temporary connection to HART/Bell 202 terminals	Two clips for temporary connection to the service port.	Two clips for temporary connection to the service port.

Input/output signal detail

Model	Descriptions
Model 2400S Analog Channel A	One active or passive 4–20 mA output <ul style="list-style-type: none"> ■ Not intrinsically safe ■ Isolated to ±50 VDC from all other outputs and earth ground ■ Maximum load limit: 820 ohms ■ External (passive) power: 12 to 30 VDC, 24 VDC typical ■ Can report mass flow, volume flow, density, temperature, or drive gain ■ Output is linear with process from 3.8 to 20.5 mA, per NAMUR NE43 (February 2003)

Input/output signal detail (Continued)

Model	Descriptions
Model 2400S Analog Channel B (configurable)	<p>One active or passive frequency/pulse output</p> <ul style="list-style-type: none"> ■ Not intrinsically safe ■ Can report mass flow or volume flow, which can be used to indicate flow rate or total ■ Scalable to 10,000 Hz ■ Power: <ul style="list-style-type: none"> - Internal (active): +24 VDC ±3% with a 2.2 kohm internal pull-up resistor - External (passive): +30 VDC maximum, +24 VDC typical (external pull-up required) ■ Output is linear with flow rate to 12,500 Hz ■ Maximum sink capability: 500 mA <p>One active or passive discrete output</p> <ul style="list-style-type: none"> ■ Not intrinsically safe ■ Can report five discrete events, flow switch, forward/reverse flow, calibration in progress, or fault ■ Power: <ul style="list-style-type: none"> - Internal (active): +24 VDC ±3% with a 2.2 kohm internal pull-up resistor - External (passive): +30 VDC maximum, +24 VDC typical ■ Maximum sink capability: 500 mA <p>One active or passive discrete input</p> <ul style="list-style-type: none"> ■ Not intrinsically safe ■ Power: <ul style="list-style-type: none"> - Internal (active): +24 VDC, 10 mA maximum source current - External (passive): +3 to 30 VDC maximum ■ Can reset all totals, reset mass total, reset volume total, start/stop totals, or start sensor zero
Model 2400S PROFIBUS-DP	<p>Digital 2-way PROFIBUS-DP signal.</p> <p>Certified by Profibus User Organization (PNO).</p>
Model 2400S DeviceNet	<p>Digital 2-way DeviceNet signal.</p> <p>Certified by Open DeviceNet Vendor Association (ODVA).</p>

Digital communications

Output type	Outputs and descriptions
Service port (all versions)	<p>One service port for temporary connections (requires removing transmitter housing cover)</p> <p>Uses RS-485 Modbus signal, 38.4 kilobaud, one stop bit, no parity</p> <p>Address: 111 (not configurable)</p>
Wireless (all versions)	<p>If transmitter has display, service port can be accessed via serial port IrDA without removing transmitter housing cover.</p>
HART/Bell 202 (Model 2400S Analog)	<p>HART signal is superimposed on the milliamp output (Channel A), and is available for host system interface:</p> <ul style="list-style-type: none"> ■ Frequency: 1.2 and 2.2 kHz ■ Amplitude: to 1.2 mA ■ 1200 baud, one stop bit, odd parity ■ Address: 0 (default), configurable ■ Requires 250 to 600 W resistance

Digital communications (Continued)

Output type	Outputs and descriptions
PROFIBUS-DP (Model 2400S PROFIBUS-DP)	Digital 2-way communication protocol <ul style="list-style-type: none"> ■ Automatically recognizes network baud rate ■ Address selectable by 3 rotary switches, or software selectable
DeviceNet (Model 2400S DeviceNet)	Digital 2-way communication protocol <ul style="list-style-type: none"> ■ Address and baud rate selectable by 3 rotary switches (2 to select address, 1 to select baud rate), or software selectable

Power supply

Analog and PROFIBUS-DP type	Description
	<ul style="list-style-type: none"> ■ Self-switching AC/DC input, automatically recognizes supply voltage. ■ Complies with low voltage directive 2006/95/EC per EN 61010-1 (IEC 61010-1). ■ Installation (Overvoltage) Category II, Pollution Degree 2.
AC	<ul style="list-style-type: none"> ■ 85-265 VAC ■ 50/60 Hz ■ 4 watts typical, 7 watts maximum
DC	<ul style="list-style-type: none"> ■ 18-100 VDC ■ 4 watts typical, 7 watts maximum
Fuse	<ul style="list-style-type: none"> ■ IEC 127-1.25 fuse, slow blow

Environmental limits

Environmental factor		°F	°C
Ambient temperature limits	Operating	-40 to +140	-40 to +60
	Storage	-40 to +158	-40 to +70
Below -4 °F (-20 °C), LCD responsiveness decreases and LCD may become difficult to read. Above 131 °F (55 °C), some darkening of the LCD panel might occur			
Humidity limits	5 to 95% relative humidity, non-condensing at 140 °F (60 °C)		
Vibration limits	Meets IEC 60068-2-6, endurance sweep, 5 to 2000 Hz, 50 sweep cycles at 1.0 g		
Housing rating	NEMA 4X (IP66/67) polyurethane-painted cast aluminum or 316L stainless steel		

Environmental effects

EMI effects

For all models:

- Complies with EMC directive 2004/108/EC per EN 61326 Industrial
- Conforms to NAMUR NE21 Version: 08.22.2007

Ambient temperature effect

For Model 2400S Analog:

On mA output: $\pm 0.005\%$ of span per °C



Hazardous area classifications

Model 2400S Analog

CSA C-US

- Class I Division 2 Groups A, B, C, D
- Class II Division 2 Groups F and G

ATEX

 II 3 G Ex nAC II T5 (Zone 2)
 II 3 D IP66/IP67 T70°C

IECEX

Ex nAC II T5

INMETRO





BR-Ex nAC IIC T5
 $-40\text{ °C} \leq T_a \leq +60\text{ °C}$

Model 2400S PROFIBUS-DP

CSA C-US

- Class I Division 2 Groups A, B, C, D
- Class II Division 2 Groups F and G

ATEX

 II 3 G Ex nAC II T5 (Zone 2)
 II 3 D IP66/IP67 T70°C

IECEX

Ex nAC II T5

Model 2400S DeviceNet

CSA C-US

- Class I Division 2 Groups A, B, C, D
- Class II Division 2 Groups F and G

IECEX

Ex nAC II T5

Physical specifications

All models

Specification	Value
Housing	NEMA 4X (IP66/67) polyurethane-painted cast aluminum or 316L stainless steel.
Weight	Transmitter is mounted integrally with sensor. For weight of flowmeter, see product data sheet for sensor.
Mounting	<ul style="list-style-type: none"> ■ Integral-mount or extended-mount ■ Available integrally mounted to Micro Motion ELITE and F-Series sensors ■ The transmitter can be rotated on the mounting in 45° increments, for eight different orientations.
With or without display	<ul style="list-style-type: none"> ■ Suitable for hazardous area installation. ■ User interface module can rotate 360° on the transmitter in 90° increments. ■ Three-color status LED on user interface module indicates flowmeter condition at a glance, using a solid green, yellow, or red light. Zero in progress is indicated by a flashing yellow light. ■ Two clips for service port connections (requires removing transmitter housing cover).
With display	<ul style="list-style-type: none"> ■ Depending on purchase option, transmitter housing cover has glass or plastic lens. ■ User interface module includes LCD panel. LCD line 1 displays process variable; line 2 displays engineering unit of measure. ■ Display update rate is user-configurable: 1 to 10 seconds at 1-second increments. ■ Display backlighting may be adjusted or turned off. ■ Operator access to transmitter menus is provided via optical switches that are operated through the lens. LED indicators show when a “button” has been pressed. ■ Infrared port allows access to service port from serial port IrDA without removing transmitter housing cover.
Without display	<ul style="list-style-type: none"> ■ Transmitter housing cover is all metal (no lens). ■ Access to user interface requires removing transmitter housing cover. ■ Zero button allows flowmeter zero from field (requires removing transmitter housing cover). ■ No IrDA port.

Model 2400S Analog

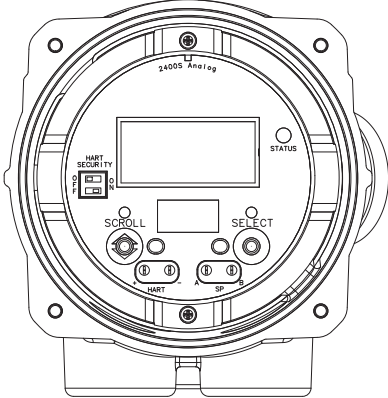
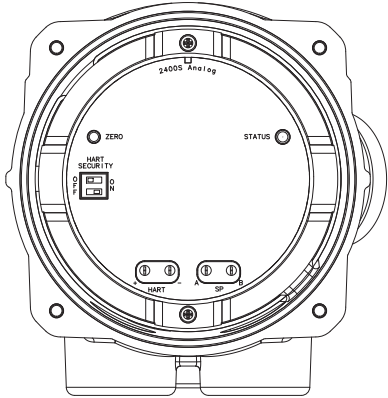
Specification	Value
With or without display	<ul style="list-style-type: none"> ■ Two clips for HART/Bell 202 connections (requires removing transmitter housing cover). ■ HART security switch (requires removing transmitter housing cover).
With display	
Without display	

Model 2400S PROFIBUS-DP

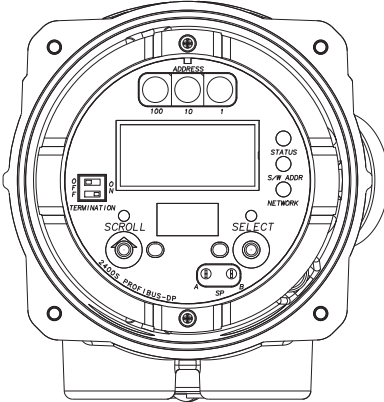
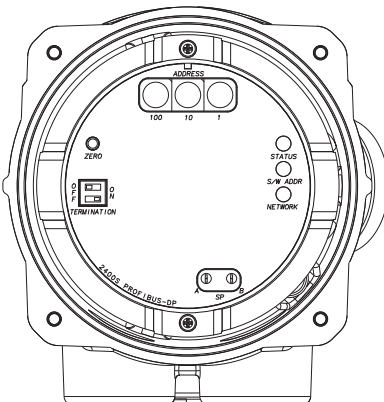
Specification	Value
With or without display	<ul style="list-style-type: none"> ■ Three rotary switches for selecting network address (network address is also software-selectable). ■ DIP switch for enabling internal termination resistor. ■ Address and network LEDs that indicate PROFIBUS-DP status.
With display	
Without display	

Model 2400S DeviceNet

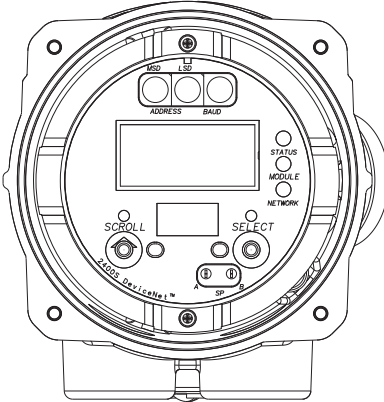
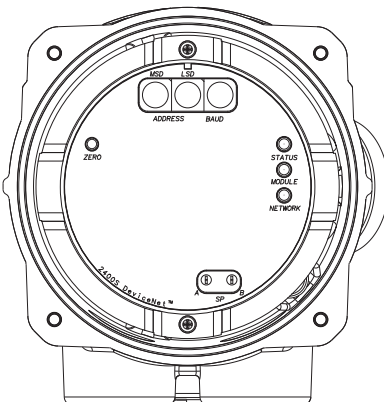
Specification	Value
With or without display	<ul style="list-style-type: none"> ■ Three rotary switches for selecting network address and baud rate (network address and baud rate are also software-selectable). ■ Module and network LEDs to indicate DeviceNet status.
With display	
Without display	

Dimensions

Dimensions for painted aluminum housing

Dimensions in inches (mm)

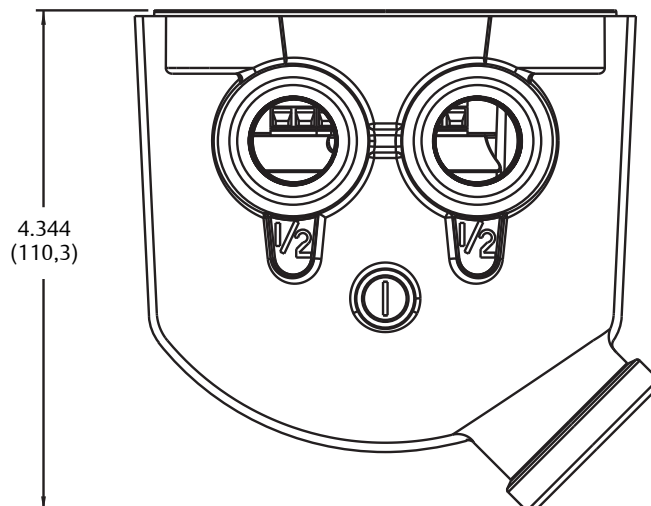
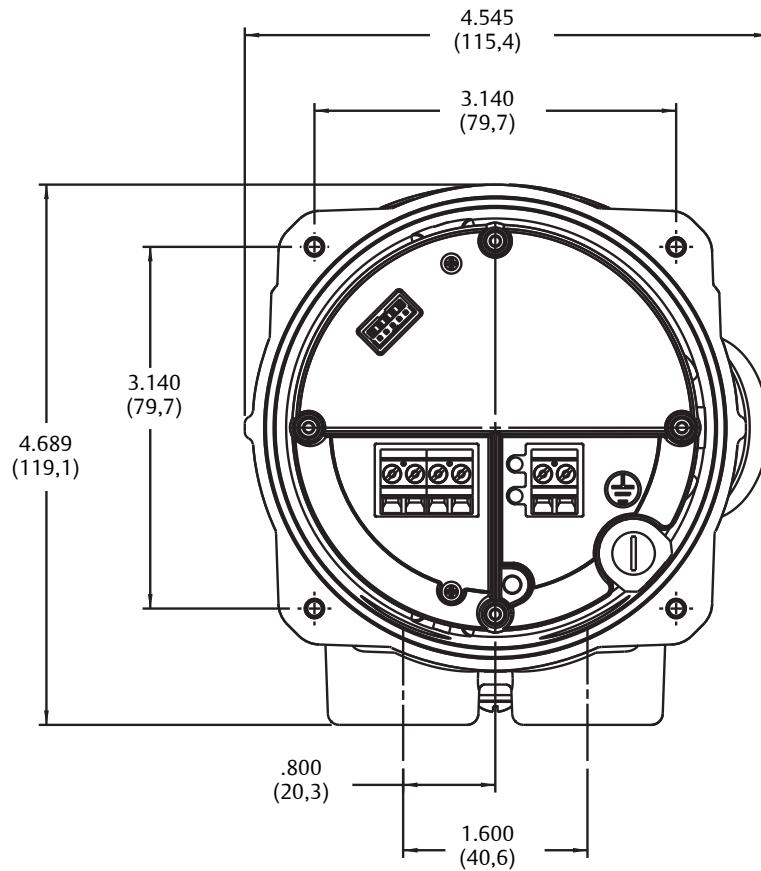

Dimensions for stainless steel housing

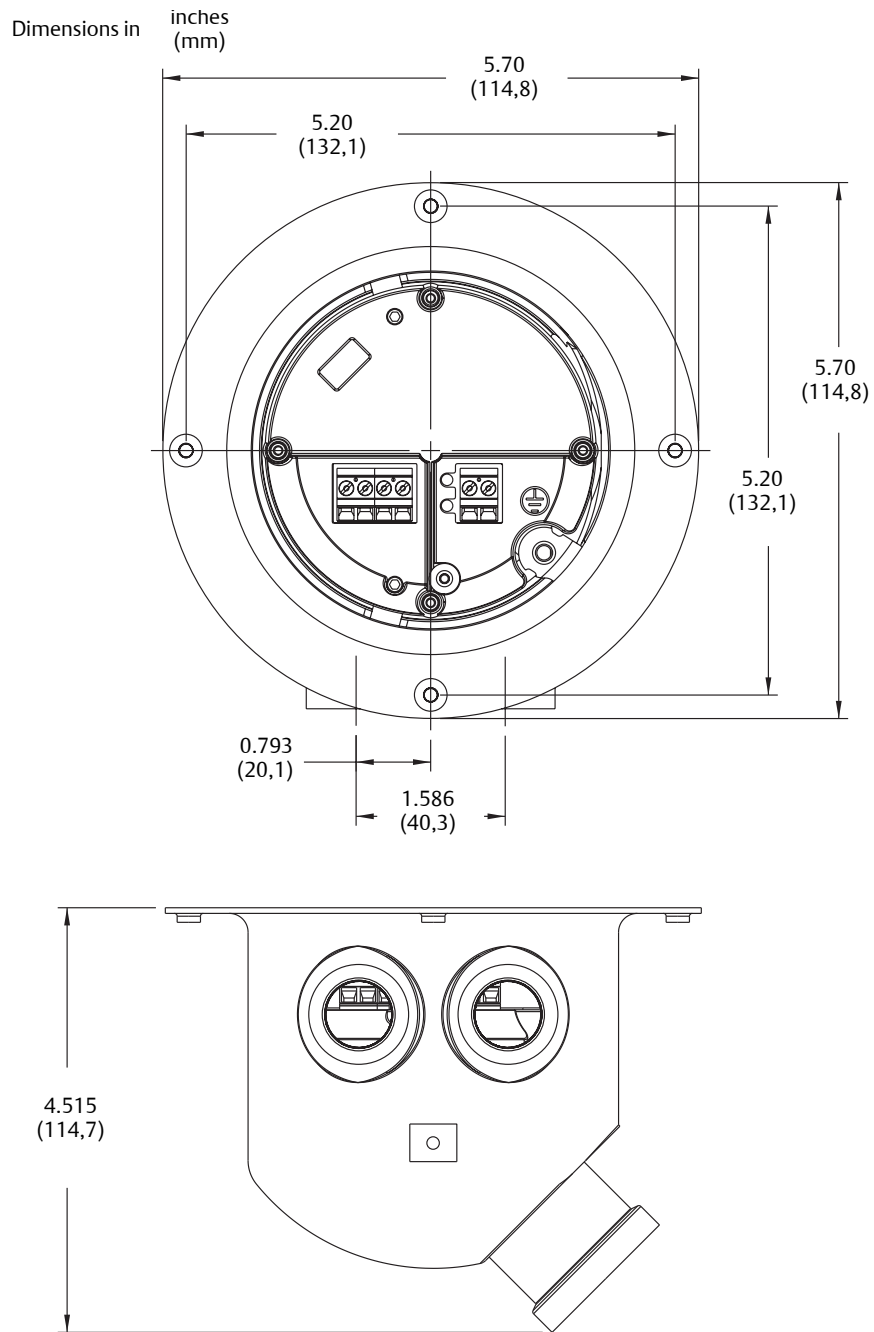

Ordering information

Product code structure for Model 2400S

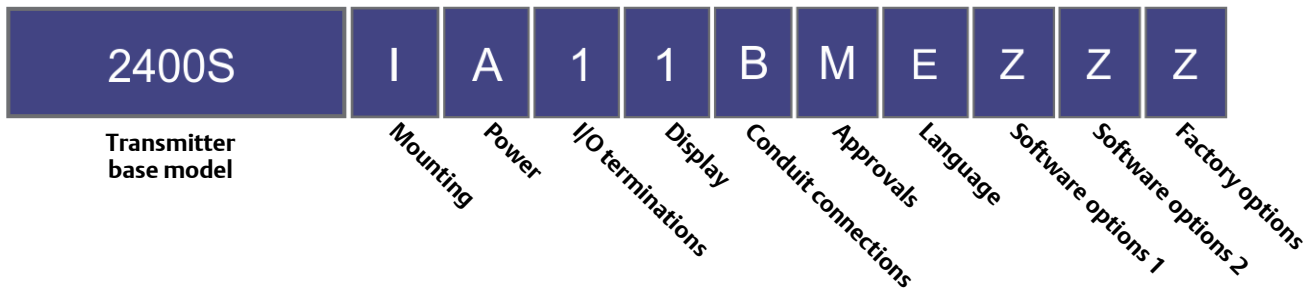

Base model

Model	Product description
2400S	Micro Motion Coriolis MVD transmitter. Must be ordered with a sensor.

Mounting

Code	Mounting options
I	Integral mount transmitter, polyurethane-painted aluminum
J ⁽¹⁾	Integral mount transmitter, 316L stainless steel

(1) Not recommended for truck-mount

Power

Code	Output options / power supply
A	One mA, one configurable output / 18 to 100 VDC and 85 to 265 VAC, self-switching
C ⁽¹⁾	DeviceNet (bus powered))
D	PROFIBUS-DP / 18 to 100 VDC and 85 to 265 VAC, self switching

(1) Requires selecting conduit connection option L or M.

I/O terminations

Code	I/O termination option
1	Compression screw terminals

Display

Code	Transmitter display options
1	Dual-line display for process variables and totalizer reset
3	No display
4 ⁽¹⁾	Non-glass dual line display for process variables and totalizer reset

(1) Not available with approval codes 2, L, 3, or G with country-specific approval R3, B3.

Conduit connections

Code	Conduit connection options
B	1/2-inch NPT – no gland
C	1/2-inch NPT with brass/nickel cable gland
D	1/2-inch NPT with stainless steel cable gland
E	M20 – no gland
F	M20 with brass/nickel cable gland
G	M20 with stainless steel cable gland
L	DeviceNet 5-pin Eurofast connector in M20 housing
M	DeviceNet 5-pin Eurofast connector in 1/2-inch NPT housing

Approvals

Code	Terminal options
M	Micro Motion standard (no approval with CE/EAC markings)
2	CSA Class I Div. 2 (U.S.A. and Canada)
L ⁽¹⁾	ATEX II 3, Zone 2
3 ⁽¹⁾	IECEX Zone 2
G ^{(1) (2)}	County-specific approval – Requires a selection in the Add-on options table

(1) Not available with approval codes 2, L, 3, or G with country-specific approval R3, B3.

(2) Requires a selection from the Approvals section of the “Add on Options”.

Language

Code	Display and documentation language
A	Danish installation manual and English configuration manual
D	Dutch installation manual and English configuration manual
E	English installation manual and English configuration manual
F	French installation manual and French configuration manual
G	German installation manual and German configuration manual
H	Finnish installation manual and English configuration manual
I	Italian installation manual and English configuration manual
J	Japanese installation manual and English configuration manual
M	Chinese installation manual and Chinese configuration manual
N	Norwegian installation manual and English configuration manual
P	Portuguese installation manual and English configuration manual
S	Spanish installation manual and Spanish configuration manual
W	Swedish installation manual and English configuration manual
C	Czech CE requirements, English installation manual, and English configuration manual
B	Hungarian CE requirements, English installation manual, and English configuration manual
K	Slovak CE requirements, English installation manual, and English configuration manual
T	Estonian CE requirements, English installation manual, and English configuration manual
O	Polish CE requirements, English installation manual, and English configuration manual
U	Greek CE requirements, English installation manual, and English configuration manual
L	Latvian CE requirements, English installation manual, and English configuration manual
V	Lithuanian CE requirements, English installation manual, and English configuration manual
Y	Slovenian CE requirements, English installation manual, and English configuration manual

Software options 1

Code	Software options 1
Z	No software options 1
G ⁽¹⁾	Enhanced density measurement
A ⁽¹⁾	Petroleum measurement

(1) Software options A and G are available only with power option codes C and D.

Software options 2

Code	Software options 2
Z	No software options 2
C	Smart Meter Verification

Factory options

Code	Factory options
Z	Standard product
X	ETO product

Add-on options

Code	Add-on options (optional)
GH	PROFIBUS-DP Eurofast M12 SST 5-pin Connector, M20
GI	PROFIBUS-DP DP Eurofast M12 SST 5-pin Connector, 1/2-inch NPT
County-specific approvals. Must select only one when approval option G is selected.	
R3 ^{(1) (2)}	EAC Zone 2 – Hazardous area approval
B3 ⁽¹⁾	INMETRO Zone 2 – Hazardous area approval

(1) Not available with approval codes 2, L, 3, or G with country-specific approval R3, B3.

(2) Available with only approval G.

Emerson Process Management Americas

7070 Winchester Circle
Boulder, Colorado USA 80301
www.MicroMotion.com
www.Rosemount.com
T: +1 800 522 6277
T: +1 (303) 527 5200
F: +1 (303) 530 8459

Mexico T: 52 55 5809 5300
Argentina T: 54 11 4837 7000
Brazil T: 55 15 3413 8000
Venezuela T: 58 26 1300 8100
Chile T: 56 2 2928 4800

Emerson Process Management Europe/Middle East

Central & Eastern Europe T: +41 41 7686 111
Dubai T: +971 4 811 8100
Abu Dhabi T: +971 2 697 2000
France T: 0800 917 901
Germany T: 0800 182 5347
Italy T: 8008 77334
The Netherlands T: +31 (0) 70 413 6666
Belgium T: +32 2 716 77 11
Spain T: +34 913 586 000
U.K. T: 0870 240 1978
Russia/CIS T: +7 495 981 9811

Emerson Process Management Asia Pacific

Australia T: (61) 3 9721 0200
China T: (86) 21 2892 9000
India T: (91) 22 6662 0566
Japan T: (81) 3 5769 6803
South Korea T: (82) 2 3438 4600
Singapore T: (65) 6 777 8211

© 2015 Micro Motion, Inc. All rights reserved.

The Emerson logo is a trademark and service mark of Emerson Electric Co. Micro Motion, ELITE, ProLink, MVD and MVD Direct Connect marks are marks of one of the Emerson Process Management family of companies. All other marks are property of their respective owners.

Micro Motion supplies this publication for informational purposes only. While every effort has been made to ensure accuracy, this publication is not intended to make performance claims or process recommendations. Micro Motion does not warrant, guarantee, or assume any legal liability for the accuracy, completeness, timeliness, reliability, or usefulness of any information, product, or process described herein. We reserve the right to modify or improve the designs or specifications of our products at any time without notice. For actual product information and recommendations, please contact your local Micro Motion representative.

