

Micro Motion[®] Series 1000 and Series 2000 Transmitters with MVD[™] Technology



Micro Motion Series 1000 and Series 2000 transmitters with MVD[™] technology deliver powerful features that make managing your process easier.

Advanced architecture with flexible installation options

- Integral or remote mounting provides maximum flexibility
- Cost-effective 4-wire interface reduces installation costs
- Remote field mount models available with stainless steel housing for harsher environments
- DIN rail option reduces complexity and increases versatility

Wide variety of I/O and application capabilities to fit your needs

- High-speed DSP for accuracy under the toughest conditions—entrained gas, high noise, high turndown, and more
- Concentration and net flow measurement eliminate the need for additional instruments
- Approved for custody transfer and certified for SIL2 and SIL3, which provides measurement confidence and reliability
- WirelessHART[®] option allows you to gain access to additional diagnostics and process information without added wiring costs

Micro Motion® Series 1000 and Series 2000 transmitters

Series 1000 and 2000 transmitters allow for the precise fit and integration for your Micro Motion Coriolis Flow and Density meters. Powerful adaptability to your installation needs combined with ultimate flexibility in output connections provides the proper fit for your application.

MVD technology makes your meter work smarter

- Front end signal processing gives faster response time and dramatically reduces signal noise
- Provides reduced wiring costs through use of standard 4 wire instrument cable
- On-board signal processing results in the cleanest, most accurate signal delivered, even with tough measurement conditions such as entrained gas

Smart Meter Verification: advanced diagnostics for your entire system

- A comprehensive test that can be run locally or from the control room to provide confidence in your meter functionality and performance
- Verifies that your meter performs as well as the day it was installed, giving you assurance in less than 90 seconds
- A basic version of Smart Meter Verification is included with new enhanced core processors that provides simple pass/fail results, and simple diagnostics that run without interrupting your processes
- A licensed version includes enhanced capabilities, such as viewing previous results and generating comprehensive reports

Mounting and Installation flexibility to fit your exact needs

- Form factors include rugged field mounts with a full suite of hazardous area approvals or DIN rail packages for cost effective control room cabinets
- Local User Interfaces provide detailed operator feedback and accessibility
- Connection to new or existing Micro Motion sensors easily achieved through flexible configurations

Connection and Interface adaptability for seamless integration

- Broad combinations of analog and frequency outputs allow for you to get signals where you need them
- Digital outputs bring a wealth of information to your control room, with offerings for Smart WirelessHART, HART™, Modbus, FOUNDATION™ fieldbus and PROFIBUS-PA
- Direct plug and play operation with the Micro Motion Ethernet/IP Module for fast, efficient communications

Overview

Feature	Model 2700	Model 2500	Model 1700	Model 1500
For applications requiring simultaneous monitoring of multiple flow variables <ul style="list-style-type: none"> Selected combinations of outputs including milliamp, frequency, and discrete I/O Modbus, HART, WirelessHART, FOUNDATION™ fieldbus, and PROFIBUS-PA digital communications Simultaneously outputs multiple variables, including: mass flow rate, volume flow rate, gas standard volume flow rate, density, temperature, and drive gain 	•	•		
For applications requiring only mass flow or volume flow measurement <ul style="list-style-type: none"> Milliamp and a frequency/pulse output HART or Modbus digital communications Outputs one of: mass flow rate, volume flow rate, or gas standard volume flow rate 			•	•
Compact, integral mounting to sensor with 360 degrees of rotation, or field mount option to a 4-wire or 9-wire Micro Motion sensor. ⁽¹⁾	•		•	
Compact, small-footprint, remote-mount transmitter using 35 mm DIN rail, with connection to either a 4-wire or 9-wire Micro Motion sensor		•		•
Class I, Division 1/Zone 1 local operator interface: <ul style="list-style-type: none"> Standard display supports English, French, Spanish, and German languages Chinese-language display supports English and Chinese languages⁽²⁾ View process variables, handle alarms, control totalizers, meter configuration, and more Interface functions can be customized and password protected 	•		•	
SIS certification: <ul style="list-style-type: none"> Available on the milliamp output with output option codes A or D One meter can be used in SIL 2 applications, and SIL 3 levels can be achieved if redundant meters are used 	•		•	
Compatible with a Smart Wireless THUM Adapter for WirelessHART capability ⁽³⁾	•	•	•	•
Available with Smart Meter Verification	•	•	•	•
Available with filling and dosing application for filling, dosing, and bottling processes. ⁽⁴⁾				•
Fuel consumption application	•	•		
Production Volume Reconciliation (PVR)	•	•	•	•
Piecewise Linearization (PWL)	•	•	•	•
Transient Bubble Remediation (TBR)	•	•	•	•
Transient Mist Remediation (TMR)	•	•	•	•

(1) Models 1700M/P and 2700M/P (stainless steel housing) are only available as remote mount.
 (2) This display is available for purchase in China only, on Model 1700 and 2700 transmitters with analog outputs. This display is certified for ATEX / NEPSI / IECEx Zone 1 use only. For detailed information regarding the approvals options available, see "Hazardous area classifications".
 (3) For more information on the Smart Wireless THUM Adapter, see the product data sheet available at www.emerson.com.
 (4) For more information on the Model 1500 transmitter with the filling and dosing application, see the product data sheet available at www.emerson.com.

Applications

Applications are custom designed programs and software available to offer additional functionality and performance to transmitters. These applications are available through options in the transmitter model code, see the ordering information section for details.

Smart Meter Verification (SMV)

- Provides a quick, complete assessment of a Coriolis meter, determining whether the meter has been affected by erosion, corrosion, or other influences affecting meter calibration.
- No secondary references are required to perform this operation, and the meter can continue normal process measurement while the test is in progress.
- A basic version of Smart Meter Verification is included with new enhanced core processors that provides simple pass/fail results, and simple diagnostics that run without interrupting your processes.

Discrete batch control

- Simple batch control based on totalizer values
- For transmitters with analog or intrinsically safe outputs, the frequency output can be configured as a discrete output.
- For transmitters with configurable I/O, a channel can be configured as a discrete output.

Weights & Measures custody transfer

- Physical and software security
- Security-alarm posting
- Mass or volume totalizer that can be configured by the user
- Compliant with MID 2014/32/EU Annex MI-005
- Certified by NTEP and OIML

Concentration measurement

Provides concentration measurement based on either industry-specific or liquid-specific units and relationships. Standard measurement options include:

- Industry-specific:
 - °Brix
 - °Plato
 - °Balling
 - °Baumé at SG60/60
 - Specific gravity
- Liquid-specific:
 - %HFCS
 - Concentration derived from reference density
 - Concentration derived from specific gravity

Additionally, the application can be customized for site-specific concentration measurement (such as %HNO₃, %NaOH).

Petroleum measurement

Adds the following calculations to the standard software:

- Calculates base density (corrected API Gravity) and Ctl (the correction for the effect of temperature on a liquid)
- Calculates gross volume at standard temperature
- Calculates flow-weighted average temperature and flow-weighted average observed gravity (flowing density)

Fuel consumption

- Automatically calculates the fluid consumption between two Coriolis flow sensors, typically for recirculating fuel consumption loops
- Eliminates the need to program an external calculation system and minimizes common inaccuracies related to time lag, sampling issues and cumulative errors
- Uses a proprietary algorithm that adapts to the unique calibration of each pair of Coriolis flow sensors

Production Volume Reconciliation (PVR)

- Provides oil and water volumes through density-based calculations for both line and reference conditions
- Detects bubble entrainment or flashing in the sensor, and can correct volumes accordingly
- Best for undersized three-phase separators that frequently have intermittent gas or water contamination in the oil leg
- Offers a simple, low-cost solution for net oil and net water measurement for two-phase separators

Transient Bubble Remediation (TBR)

- Used with single-component liquid streams that may experience intermittent low levels of gas entrainment, that is, gas carryunder
- Enables accurate measurement of a single fluid during periods of entrained gas by providing a substitute density value based on the immediately preceding process density (standard configuration)
- Tracks total time of aerated flow to assist in diagnosing process issues that may cause aeration

Transient Mist Remediation (TMR)

- Used with gas streams that may experience intermittent low levels of liquid entrainment, i.e., liquid carry-over
- Allows gas measurement to continue during periods of entrained liquid (mist) by providing a substitute flow rate value based on the immediately preceding process flow rate
- Returns to reporting the measured flow rate when the mist interval is over, increased or decreased by a maximum of 10%, until flow totals are appropriately adjusted for the unmeasured flow
- Provides an indication of the amount of time that liquid was present in the stream — identifying process improvements to reduce gas stream contamination

Piecewise Linearization (PWL) for gas applications

- Allows third-party gas calibration laboratories to use up to 10 calibration points to make the meter response linear
- Not included for third-party calibration service

Electrical connections

Connection type	Model 2700	Model 1700	Model 2500	Model 1500
Input/Output	<ul style="list-style-type: none"> Three pairs of wiring terminals for transmitter I/O and communications 	<ul style="list-style-type: none"> Intrinsically safe version: Two pairs of wiring terminals for transmitter outputs Non-intrinsically safe analog outputs (output option A): Three pairs of wiring terminals for transmitter outputs 	<ul style="list-style-type: none"> Three pairs of wiring terminals for transmitter outputs One pair of terminals for digital communications (Modbus/RS-485) 	
Power	<ul style="list-style-type: none"> One pair of wiring terminals accepts AC or DC power One internal ground lug for power-supply ground wiring 		<p>The transmitter has two pairs of terminals for the power connection:</p> <ul style="list-style-type: none"> Either pair accepts DC power The remaining pair can be used for making a jumper connection to a second transmitter 	
Service port	Two clips for temporary connection to the service port		One pair of terminals supports Modbus/RS-485 signal or service port mode. On device power-up, user has 10 seconds to connect in service port mode. After 10 seconds, the terminals default to Modbus/RS-485 mode.	

Note

- Each screw terminal connection accepts one or two solid conductors, 14 to 12 AWG (2.5 to 4.0 mm²) or one or two stranded conductors, 22 to 14 AWG (0.34 to 2.5 mm²). Each plug type connector accepts one stranded or solid conductor, 24 to 12 AWG (0.20 to 2.5 mm²).
- For Model 1700/2700 transmitters with an integral core processor (mounting code C), the 4-wire connection between the transmitter and core processor is not normally accessed.

Output summary

Model	Output code	Channel A	Channel B	Channel C	Channel D
1500	A	mA w/ Bell 202 HART	unused	FO/DO	RS-485 HART and Modbus
	C ⁽¹⁾	mA	DO	DO/DI	RS-485Modbus
2500	B	mA w/ Bell 202 HART	configurable to mA, FO, or DO (default mA)	configurable to FO, DO, or DI (default FO)	RS-485 HART and Modbus
	C	mA w/ Bell 202 HART	configurable to mA, FO, or DO (custom)	configurable to FO, DO, or DI (custom)	RS-485 HART and Modbus
1700	A	mA w/ Bell 202 HART	FO/DO	RS485 HART and Modbus	N/A
	D	mA w/ Bell 202 HART	FO/DO	unused	N/A
2700	A	mA w/ Bell 202 HART	FO/DO	RS485 HART and Modbus	N/A
	B	mA w/ Bell 202 HART	configurable to mA, FO, or DO (default mA)	configurable to FO, DO, or DI (default FO)	N/A

Model	Output code	Channel A	Channel B	Channel C	Channel D
	C	mA w/ Bell 202 HART	configurable to mA, FO, or DO (custom)	configurable to FO, DO, or DI (custom)	N/A
	D	mA w/ Bell 202 HART	FO/DO	mA	N/A
	E	FOUNDATION Fieldbus (FISCO)	unused	unused	N/A
	G	Profibus PA	unused	unused	N/A
	N	FOUNDATION Fieldbus (FNICO)	unused	unused	N/A
	2 ⁽²⁾	mA w/ Bell 202 HART	FO/DO	RS485 HART and Modbus	N/A
	3 ⁽²⁾	mA w/ Bell 202 HART	configurable to mA, FO, or DO (custom)	configurable to FO, DO, or DI (custom)	N/A
	4 ⁽²⁾	mA w/ Bell 202 HART	FO	mA	N/A

(1) Requires filling and dosing software package.

(2) Output codes 2, 3, and 4 include a Model 2700 transmitter housing with extra conduit connection for 775 THUM mounting capability.

Legend

FO = Frequency/pulse output, scalable to 10,000 Hz

DO = Discrete output

DI = Discrete input

BOLD = intrinsically safe outputs

Input/output signal detail

Code	Description
All	Inputs for all codes <ul style="list-style-type: none"> ■ With mounting codes R, M, and B: One 4-wire sensor signal input connection, intrinsically safe ■ With mounting codes C and P (9-wire remote transmitter): One 9-wire sensor signal input connection, intrinsically safe
Output code A or 2 Non-intrinsically safe analog output (with HART and Modbus); Model 1500, Model 1700, and Model 2700 transmitter	One active 4–20 mA output <ul style="list-style-type: none"> ■ Not intrinsically safe ■ Isolated to ±50 VDC from all other outputs and earth ground ■ Maximum load limit: 820 ohms ■ Model 1500 and Model 1700 can report mass flow or volume flow ■ Model 2700 can report mass flow, volume flow, density, temperature, or drive gain ■ Output is linear with process from 3.8 to 20.5 mA, per NAMUR NE43 (February 2003)

Code	Description
	<p>One active frequency/pulse output</p> <ul style="list-style-type: none"> ■ Not intrinsically safe ■ Can report mass flow or volume flow, which can be used to indicate flow rate or total ■ For Model 1500 and Model 1700, frequency output reports the same flow variable as the mA output ■ For Model 2700, frequency output is independent of mA output ■ Scalable to 10,000 Hz ■ For Model 1500 and 2500, output voltage is +15 VDC \pm3% with a 2.2 kohm internal pull-up resistor ■ For Model 1700 and Model 2700, output voltage is +24 VDC \pm3% with a 2.2 kohm internal pull-up resistor ■ Output is linear with flow rate to 12,500 Hz ■ Configurable polarity: active high or active low ■ Model 1700 discrete output: Can be configured as a discrete output to report flow direction and flow switch ■ Model 2700 discrete output: Can be configured as a discrete output to report five discrete events, flow direction, flow switch, calibration in progress, or fault. ■ On Model 1700 and Model 2700 transmitters, this can also be configured as a discrete output
<p>Output codes B, C, and 3</p> <p>Non-intrinsically safe configurable output Model 2500 and Model 2700 transmitters. Transmitter has a total of 3 configurable inputs/outputs. Refer to the data below and the information on page 10 for the ways that these 3 inputs/outputs can be configured</p>	<p>One or two active 4–20 mA outputs</p> <ul style="list-style-type: none"> ■ Not intrinsically safe ■ Isolated to \pm50 VDC from all other outputs and earth ground ■ Maximum load limit of mA1: 820 ohms; of mA2: 420 ohms ■ Can report mass flow, volume flow, density, temperature, or drive gain ■ Output is linear with process from 3.8 to 20.5 mA, per NAMUR NE43 (February 2003) <p>One or two active or passive frequency/pulse outputs</p> <ul style="list-style-type: none"> ■ Not intrinsically safe ■ Can report mass flow or volume flow, which can be used to indicate flow rate or total ■ If configured as a dual pulse output, the channels are electrically isolated but not independent (see custody transfer note below) ■ Scalable to 10,000 Hz ■ If active, output voltage is +15 VDC \pm3% with a 2.2 kohm internal pull-up resistor ■ If passive, output voltage is 30 VDC maximum, 24 VDC typical, sinking up to 500 mA at 30 VDC. ■ Output is linear with flow rate to 12,500 Hz
<p>Output codes B, C, and 3 (continued)</p>	<p>One or two active or passive discrete outputs</p> <ul style="list-style-type: none"> ■ Not intrinsically safe ■ Can report five discrete events, flow switch, forward/reverse flow, calibration in progress, or fault ■ If active, output voltage is +15 VDC \pm3% with a 2.2 kohm internal pull-up resistor ■ If passive, output voltage is 30 VDC maximum, 24 VDC typical, sinking up to 500 mA at 30 VDC <p>One discrete input</p> <ul style="list-style-type: none"> ■ Can be configured for active or passive power ■ Not intrinsically safe ■ Active power +15 VDC, 7 mA maximum source current ■ Passive power +3–30 VDC maximum ■ Can start/stop totals and inventories, reset all totals, reset mass total, reset volume total, start sensor zero, or initiate multiple actions

Code	Description
	<p>Custody transfer using double-pulse frequency output</p> <p>The transmitter can be configured for two frequency outputs. The second output can be phase-shifted -90, 0, 90, or 180 degrees from the first output, or the dual-pulse output can be set to quadrature mode</p>
<p>Output codes E and G</p> <p>Intrinsically safe FOUNDATION™ fieldbus and PROFIBUS-PA Model 2700 transmitters</p>	<p>One FOUNDATION fieldbus H1 or PROFIBUS-PA output</p> <ul style="list-style-type: none"> ■ FOUNDATION fieldbus and PROFIBUS-PA wiring is intrinsically safe with an intrinsically safe power supply ■ The transmitter fieldbus circuit is passive, and draws power from the fieldbus segment. Current draw from the fieldbus segment is 13 mA ■ Manchester-encoded digital signal conforms to IEC 61158-2
<p>Output code N</p> <p>Non-incendive FOUNDATION fieldbus transmitters.</p>	<p>One FOUNDATION fieldbus H1 output</p> <ul style="list-style-type: none"> ■ FOUNDATION fieldbus wiring is non-incendive ■ The transmitter fieldbus circuit is passive, and draws power from the fieldbus segment. Current draw from the fieldbus segment is 13 mA ■ Manchester-encoded digital signal conforms to IEC 61158-2
<p>Output codes D and 4</p> <p>Intrinsically safe Model 1700 and Model 2700 transmitters</p>	<p>One intrinsically safe passive 4–20mA output (two with Model 2700)</p> <ul style="list-style-type: none"> ■ Maximum input voltage: 30 VDC, 1 watt maximum ■ Maximum load limit: see chart below ■ Model 1700 can report mass flow or volume flow; Model 2700 can report mass flow, volume flow, density, temperature, or drive gain ■ Entity parameters: $U_i = 30$ VDC, $I_i = 300$ mA, $P_i = 1$ W, $C_i = 0.0005$ μF, $L_i =$ Less than 0.05 mH ■ Output is linear with process from 3.8 to 20.5 mA, per NAMUR NE43 (February 2003) <p style="text-align: center;">mA Output Load Resistance Value $R_{max} = (V_{supply} - 12) / 0.023$ *</p> <p style="text-align: center;">*If communicating with HART, a minimum of 250 ohms and 17.75 V supply is needed</p> <p>A. External resistor (ohms) B. Operating region C. Supply voltage (volts)</p>

Code	Description
	<p>One intrinsically safe frequency/pulse output or configurable frequency/pulse/discrete output</p> <ul style="list-style-type: none"> ■ Maximum input voltage: 30 VDC, 0.75 watt maximum ■ Maximum load limit: see chart below ■ Can report mass flow or volume flow, which can be used to indicate flow rate or total ■ For Model 1700, frequency output reports the same flow variable as the mA output ■ For Model 2700, frequency output is independent of the mA output ■ Scalable to 10,000 Hz ■ Entity parameters: $U_i = 30$ VDC, $I_i = 100$ mA, $P_i = 0.75$ W, $C_i = 0.0005$ μF, $L_i =$ Less than 0.05 mH ■ Output is linear with flow rate to 12,500 Hz <p style="text-align: center;">Frequency Output Load Resistance Value</p> $R_{\max} = (V_{\text{supply}} - 4) / 0.003$ $*R_{\min} = (V_{\text{supply}} - 25) / 0.006$ <p style="text-align: center;">*Absolute minimum=100 ohms for $V_{\text{supply}} < 25.6$ volts</p> <p>A. External resistor (ohms) B. Operating region C. Supply voltage (volts)</p>

Series 2000 transmitters with configurable I/O functionality

The Series 2000 transmitter with configurable inputs and outputs is designed to increase transmitter flexibility and reduce the number of transmitter variations required in inventory. The table below shows the various configuration options that can be produced with the configurable I/O output option.

Channel assignments for Series 2000 transmitters with configurable I/O (output option codes B, C, and 3)

- When output code B is selected, the transmitter ships with channels assigned to default values.
- When output codes C or 3 are selected, the transmitter is custom configured prior to shipment. Output code 3 is only available with Model 2700 transmitters.

Channel	Terminals		Configuration options	Default variable assignment	Power
	Model 2700	Model 2500			
A	1 & 2	21 & 22	mA output with Bell 202/HART (only)	Mass flow	Active
B	3 & 4	23 & 24	mA output (default)	Density	Active
			Frequency output ⁽¹⁾	Mass flow	Active or passive ⁽²⁾

Channel	Terminals		Configuration options	Default variable assignment	Power
	Model 2700	Model 2500			
			Discrete output	Fwd/rev flow	Active or passive
C	5 & 6	31 & 32	Frequency output (default) ⁽¹⁾	Mass flow	Active or passive
			Discrete output	Flow switch	Active or passive
			Discrete input	None	Active or passive

- (1) If channels B and C are both configured as a frequency output (dual pulse), both outputs are generated from the same signal. The outputs are electrically isolated but not independent.
- (2) The user must supply power when a channel is set to passive power.

Digital communications

Output type	Outputs and descriptions
All	<ul style="list-style-type: none"> ■ One service port can be used for temporary connection only ■ Uses RS-485 Modbus signal, 38.4 kilobaud, one stop bit, no parity
HART/RS-485, Modbus/RS-485	<ul style="list-style-type: none"> ■ Models/output codes: <ul style="list-style-type: none"> - All models with output code A, except when ordered with display code 8 - Model 2500 with output codes B and C - Model 2700 with output code 2 ■ One RS-485 output can be used for direct connection to a HART or Modbus host system; accepts data rates between 1200 baud and 38.4 kilobaud ■ HART revision 7 as default, selectable to HART revision 5
HART/Bell 202	<ul style="list-style-type: none"> ■ Models/output codes: Model 1500 with output code A, Models 1700 and 2500 with output codes A, B, C, and D. Model 2700 with output codes A, B, C, D, 2, 3, and 4 ■ HART Bell 202 signal is superimposed on the primary milliamp output, and is available for host system interface. Frequency 1.2 and 2.2 kHz, Amplitude: to 1.0 mA, 1200 baud, Requires 250 to 600 ohms load resistance ■ HART revision 7 as default, selectable to HART revision 5
FOUNDATION™ fieldbus	<ul style="list-style-type: none"> ■ Models/output codes: <ul style="list-style-type: none"> - Model 2700 with output code E - Model 2700 with output code N ■ Transmitters are registered with the Fieldbus Foundation, and conform to the FOUNDATION fieldbus H1 protocol specification. Transmitters with output code E are FISCO certified. Transmitters with output code N are FNICO certified ■ FISCO: <ul style="list-style-type: none"> - Field device in compliance with EN/IEC 60079-11:2012 Annex G - $U_i = 30\text{ V}$, $I_i = 380\text{ mA}$, $P_i = 5.32\text{ W}$, $C_i = 0.0005\text{ }\mu\text{F}$, $L_i = \text{Less than } 0.05\text{ mH}$ ■ Non intrinsically safe FF output
PROFIBUS-PA	<ul style="list-style-type: none"> ■ Model 2700 with output code G ■ Transmitters are registered with the Profibus Organization, and fulfill the requirements of the PROFIBUS-PA Profile for Process Control Devices. Compatible for configuration with Siemens® Simatic® PDM ■ FISCO: <ul style="list-style-type: none"> - Field device in compliance with EN/IEC 60079-11:2012 Annex G - $U_i = 30\text{ V}$, $I_i = 380\text{ mA}$, $P_i = 5.32\text{ W}$, $C_i = 0.0005\text{ }\mu\text{F}$, $L_i = \text{Less than } 0.05\text{ mH}$

Model 2700 transmitter with FOUNDATION™ fieldbus

Fieldbus software functionality

The Model 2700 FOUNDATION fieldbus software is designed to permit remote testing and configuration of the transmitter using the DeltaV™ Fieldbus Configuration Tool, or other FOUNDATION fieldbus compliant hosts. The Coriolis sensor signal is channelled through the flowmeter to the control room and the FOUNDATION fieldbus configuration device.

Transducer blocks

Transducer blocks hold data from the Coriolis sensor, including process variables, configuration, calibration, and diagnostics.

The Model 2700 transmitter with FOUNDATION fieldbus provides up to seven transducer blocks:

- Measurement - For process variables
- Calibration - For calibration information
- Diagnostic- For diagnosing problems and running diagnostic tests (including the Smart Meter Verification procedure, if the transmitter is paired with an enhanced core processor)
- Device Information - For data such as sensor type
- Local Display - For configuring the transmitter display
- API - For petroleum measurement calculations using API MPMS Chapter 11.1
- Concentration Measurement
- For complex density and concentration calculations (e.g., %HFCS, SG60/60)

Resource block

The resource block contains physical device information, including available memory, manufacturer identification, type of device, and features.

Analog input function blocks

The Analog Input (AI) function block processes the measurement from the Coriolis sensor and makes it available to other function blocks. It also allows filtering, alarm handling, and engineering unit changes. Each of the four Model 2700 AI blocks can be assigned to one of 19 available variables.

Analog output block

The AO function block assigns an output value to a field device through a specified channel. The block supports mode control, signal status calculation, and simulation. The AO block can report either pressure from an external pressure source or temperature from an external temperature source.

Discrete input block

One permanent Discrete Input (DI) function block can be assigned to any of the discrete input variable channels in the transducer block. The DI block channels are: forward/reverse indication, zero in progress, fault condition indication, and meter verification failure.

Discrete output block

One permanent Discrete Output (DO) function block can be assigned to any of the discrete output variable channels in the transducer block. The DO block channels are: start sensor zero, reset mass total, reset volume total, reset API reference (standard) volume total, reset all process totals, reset concentration measurement reference volume total, reset concentration measurement net mass total, reset concentration measurement net volume total, start/stop all totals, increment concentration measurement curve, reset gas standard volume total, and start meter verification in continuous measurement mode.

Proportional integral derivative block

The optional proportional integral derivative (PID) function block combines all the necessary logic to perform proportional/integral/derivative control. The block supports mode control, signal scaling and limiting, feed forward control, override tracking, alarm limit detection, and signal status propagation.

Integrator block

The integrator block provides functionality for the transmitter totalizers. Any process total can be selected and reset.

Diagnostics and service

Model 2700 transmitters automatically perform continuous self diagnostics. Using the Diagnostic transducer block, the user can perform on-line testing of the transmitter and sensor. Diagnostics are event driven and do not require polling for access.

PlantWeb® Field Diagnostic is supported. The diagnostic information is based on NAMUR NE 107 standard.

Power supply

Model	Description
Model 1700 and Model 2700	<ul style="list-style-type: none"> ■ Self switching AC/DC input, automatically recognizes supply voltage ■ Complies with low voltage directive 2014/35/EU per EN 61010-1 (IEC 61010-1) with amendment 2; Installation (Overvoltage) Category II, Pollution Degree 2 ■ AC power: 85 to 265 VAC, 50/60 Hz, 6 watts typical, 11 watts maximum ■ DC power: <ul style="list-style-type: none"> - 18 to 100 VDC, 6 watts typical, 11 watts maximum - Minimum 22 VDC with 1000 feet of 18 AWG (300 meters of 0.8 mm²) power-supply cable - At startup, transmitter power source must provide a minimum of 1.5 amperes of short-term current at a minimum of 18 volts at the transmitter’s power input terminals ■ Fuse: IEC 127-1.25 non-serviceable fuse, slow blow
Model 1500 and Model 2500	<ul style="list-style-type: none"> ■ Transmitter power supply meets Installation (Overvoltage) Category II, Pollution Degree 2 requirements ■ DC power: <ul style="list-style-type: none"> - Minimum 19.2 to 28.8 VDC, 6.3 watts - At startup, transmitter power source must provide a minimum of 1.0 amperes of short-term current per transmitter - Length and conductor diameter of the power cable must be sized to provide 19.2 VDC minimum at the power terminals, at a load current of 330 mA ■ Fuse: IEC 1.6A non-serviceable fuse, slow blow

Environmental limits

Environmental factor		°F	°C
Ambient temperature limits	Model 1700/2700 ^{(1) (2)}	Operating	-40 to +140
		Storage	-40 to +140
	Model 1500/2500 ⁽³⁾	Operating	-40 to +131
		Storage	-40 to +185
Humidity limits	5 to 95% relative humidity, non-condensing at 140 °F (60 °C)		
Vibration limits	Meets IEC 60068.2.6, endurance sweep, 5 to 2000 Hz, 50 sweep cycles at 1.0 g		

Environmental factor		°F	°C
Housing rating	Model 1700/2700	NEMA 4X (IP66/67/69(K)) ⁽⁴⁾	
	Model 1500/2500	None	

- (1) Display responsiveness decreases, and display may become difficult to read, below -4°F (-20°C). Above 131°F (55°C), some darkening of display might occur.
- (2) ATEX approvals require limiting ambient temperature to 140°F (60°C) on Model 1700/Model 2700 core processors (for example, Model 1700C/Model 2700C); UL approvals require limiting ambient temperature to below 140°F (60°C).
- (3) If the temperature is above 131°F (55°C), and you are mounting multiple transmitters, the transmitters must be at least 8.5mm apart.
- (4) The protection is IP69K-based NEN-ISO 20653:2013 and IP69 when using standard IEC/EN 60529.

Environmental effects

EMI effects

- Complies with EMC directive 2014/30/EU per EN 61326 Industrial
- Complies with NAMUR NE-21 (May 2012). With the exception of voltage dip when powered by 24 VDC on 1700/2700 transmitters

Ambient temperature effect

- On analog outputs: $\pm 0.005\%$ of span per $^{\circ}\text{C}$ change from temperature at which the outputs were trimmed

Hazardous area classifications

Model 1700 and Model 2700

UL, CSA, and CSA-US

- Ambient temperature is limited to -40°F (-40°C) to 140°F (60°C) for UL and CSA compliance.
- Class I, Div. 1, Groups C and D. Class II, Div. 1, Groups E, F, and G explosion proof (when installed with approved conduit seals). Otherwise, Class I, Div. 2, Groups A, B, C, and D.
- Provides nonincendive sensor outputs for use in Class I, Div. 2, Groups A, B, C, and D; or intrinsically safe sensor outputs for use in Class I, Div. 1, Groups C and D or Class II, Div. 1, Groups E, F, and G.

IECEx

- Ambient temperature is limited to -40°F (-40°C) to 131°F (55°C) for IECEx compliance. Transmitters with output codes A, B, C, D, E, G, and N are rated for increased safety or flameproof with approved cable glands.

Output option	Code	Approval		
Analog outputs	A	Flameproof	Ex d [ib] IIB+H2 T5 Gb	Standard display or Chinese-language display
			Ex d [ib] IIC T5 Gb	No display or IIC display
Configurable I/O	B or C	Flameproof	Ex d [ib] IIB+H2 T5 Gb	Standard display
			Ex d [ib] IIC T5 Gb	No display or IIC display
FOUNDATION™ fieldbus (non-intrinsically safe)	N	Flameproof	Ex d [ib] IIB+H2 T5 Gb	Standard display
			Ex d [ib] IIC T5 Gb	No display or IIC display
Intrinsically safe	D	Flameproof	Ex d [ia Ga] [ib] IIB+H2 T5 Gb	Standard display
			Ex d [ia Ga] [ib] IIC T5 Gb	No display or IIC display

Output option	Code	Approval		
FOUNDATION fieldbus (IS), or PROFIBUS-PA ⁽¹⁾	E or G	Flameproof	Ex d [ia Ga] [ib] IIB+H2 T5 Gb	Standard display
			Ex d [ia Ga] [ib] IIC T5 Gb	No display or IIC display
Intrinsically safe	D	Increased Safety	Ex de [ia Ga] [ib] IIB+H2 T5 Gb	Standard display
			Ex de [ia Ga] [ib] IIC T5 Gb	No display or IIC display
FOUNDATION fieldbus (IS), or PROFIBUS-PA	E or G	Increased Safety	Ex de [ia Ga] [ib] IIB+H2 T5 Gb	Standard display
			Ex de [ia Ga] [ib] IIC T5 Gb	No display or IIC display
I.S. with WirelessHART	4	Increased safety ⁽²⁾	Ex de [ia Ga] [ib] IIB+H2 T4 Gb	Standard display
			Ex de [ia Ga] [ib] IIC T4 Gb	No display or IIC display
Non-I.S. with WirelessHART	2 or 3	non-Sparking	Ex nA de [ib Gb] IIB+H2 T4 Gc	Standard display
			Ex nA de [ib Gb] IIC T4 Gc	No display or IIC display

(1) Output codes E and G are FISCO field devices in compliance with IEC 60079-11:2012.

(2) Models 1700M, 1700P, 2700M, and 2700P (stainless steel housing) are limited to flameproof (Exd) rating.

ATEX

Ambient temperature is limited to below 140 °F (60 °C) for ATEX compliance. Transmitters with output codes A, B, C, D, E, G, and N are rated for increased safety or flameproof with approved cable glands.

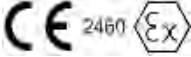
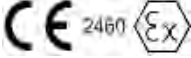
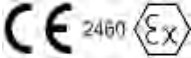
Output option	Code	Approval			
Analog outputs	A	 II 2G II 2D Ex tb IIIC T65 °C Db IP66/IP67	Increased safety ⁽¹⁾	Ex de [ib] IIB+H2 T5 Gb	Standard display or Chinese-language display
				Ex de [ib] IIC T5 Gb	No display or IIC display
			Flameproof	Ex d [ib] IIB+H2 T5 Gb	Standard display or Chinese-language display
				Ex d [ib] IIC T5 Gb	No display or IIC display
Configurable I/O	B or C	 II 2G II 2D Ex tb IIIC T65 °C Db IP66/IP67	Increased safety ⁽²⁾	Ex de [ib] IIB+H2 T5 Gb	Standard display
				Ex de [ib] IIC T5 Gb	No display or IIC display
			Flameproof	Ex d [ib] IIB+H2 T5 Gb	Standard display
				Ex d [ib] IIC T5 Gb	No display or IIC display
FOUNDATION fieldbus (non-intrinsically safe)	N	 II 2G II 2D Ex tb IIIC T65 °C Db IP66/IP67	Increased safety ⁽²⁾	Ex de [ib] IIB+H2 T5 Gb	Standard display
				Ex de [ib] IIC T5 Gb	No display or IIC display
			Flameproof	Ex d [ib] IIB+H2 T5 Gb	Standard display
				Ex d [ib] IIC T5 Gb	No display or IIC display

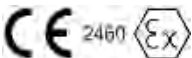
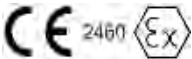
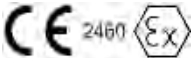
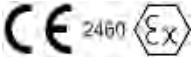
Output option	Code	Approval	
Intrinsically safe	D	 II (1) 2G II 2D Ex tb IIIC T65 °C Db IP66/IP67	
		Increased safety ⁽²⁾	Ex de [ia Ga] [ib] IIB+H2 T5 Gb Standard display Ex de [ia Ga] [ib] IIC T5 Gb No display or IIC display
		Flameproof	Ex d [ia Ga] [ib] IIB+H2 T5 Gb Standard display
			Ex d [ia Ga] [ib] IIC T5 Gb No display or IIC display
FOUNDATION fieldbus (IS), or PROFIBUS-PA ⁽²⁾	E or G	 II (1) 2G II 2D Ex tb IIIC T65 °C Db IP66/IP67	
		Increased safety ⁽²⁾	Ex de [ia Ga] [ib] IIB+H2 T5 Gb Standard display Ex de [ia Ga] [ib] IIC T5 Gb No display or IIC display
		Flameproof	Ex d [ia Ga] [ib] IIB+H2 T5 Gb Standard display
			Ex d [ia Ga] [ib] IIC T5 Gb No display or IIC display
I.S. with WirelessHART	4	 II (1) 2G	
		Increased safety ⁽²⁾	Ex de [ia Ga] [ib] IIB+H2 T4 Gb Standard display Ex de [ia Ga] [ib] IIC T4 Gb No display or IIC display
Non-I.S. with WirelessHART	2 or 3	 II (2) 3G	
		non-Sparking	Ex nA de [ib Gb] IIB+H2 T4 Gc Standard display Ex nA de [ib Gb] IIC T4 Gc No display or IIC display

(1) Models 1700M, 1700P, 2700M, and 2700P (stainless steel housing) are limited to flameproof (Exd) rating.

(2) Output codes E and G are FISCO field devices in compliance with EN/IEC 60079-11:2012 Annex G.

NEPSI

Output option	Code	Approval	
Analog outputs	A	Increased safety ⁽¹⁾	Ex de [ib] IIB+H2 T5 Gb Standard display or Chinese-language display Ex de [ib] IIC T5 Gb No display or IIC display
		Flameproof	Ex d [ib] IIB+H2 T5 Gb Standard display or Chinese-language display
			Ex d [ib] IIC T5 Gb No display or IIC display
		Configurable I/O	B or C
Flameproof	Ex d [ib] IIB+H2 T5 Gb Standard display		
	Ex d [ib] IIC T5 Gb No display or IIC display		
Intrinsically safe	D		
		Flameproof	Ex d [ia/ib] IIB+H2 T5 Gb Standard display

Output option	Code	Approval		
			Ex d [ia/ib] IIC T5 Gb	no display or IIC display
FOUNDATION fieldbus (IS), or PROFIBUS-PA ⁽¹⁾	E or G	Increased safety ⁽¹⁾	Ex de [ia/ib] IIB+H2 T5 Gb	Standard display
			Ex de [ia/ib] IIC T5 Gb	No display or IIC display
		Flameproof	Ex d [ia/ib] IIB+H2 T5 Gb	Standard display
			Ex d [ia/ib] IIC T5 Gb	No display or IIC display

(1) Output codes E and G are FISCO field devices in compliance with EN/IEC 60079-11:2012 Annex G.

Model 1500 and 2500

CSA and CSA-US

- Transmitter (when installed in a suitable enclosure): Class I, Div. 2, Groups A, B, C, and D.
- Sensor, including wiring to sensor: Class I, Div. 1, Groups C and D or Class II, Div. 1, Groups E, F, and G.

ATEX

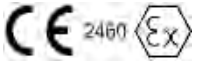
Ambient temperature	Limited to -40 to +131 °F (-40 to +55 °C) for ATEX compliance
Operating conditions: Environmental	 II (2) 3G [EEx ib] IIB/IIC

Marine approval classifications

Marine approval	Country
Det Norske Veritas- Germanischer Lloyd (Models 1500 and 2500 only)	Norway-Germany
American Bureau of Shipping (all models)	USA

Physical specifications

Model 1700 and Model 2700

Specification	Value		
Housing	<ul style="list-style-type: none"> ■ Polyurethane-painted cast aluminum or CF3M stainless steel; NEMA 4X (IP66) 		
Weight ⁽¹⁾	<ul style="list-style-type: none"> ■ Painted aluminum, 4-wire remote: <ul style="list-style-type: none"> ■ with display: 8 lb (4 kg) ■ without display: 7 lb (3kg) ■ Painted aluminum, 9-wire remote: <ul style="list-style-type: none"> ■ With display: 14 lb (6 kg) ■ Without display: 13 lb (6 kg) ■ Stainless steel: <ul style="list-style-type: none"> ■ With display: 21 lb (10 kg) ■ Without display: 20 lb (9 kg) ■ Option with Smart Wireless THUM Adapter: Add 0.65 lb (0.29 kg) to transmitter weight 		
Terminal compartments	<ul style="list-style-type: none"> ■ Output terminals are physically separated from the power and service-port terminals. 		
Cable gland entrances	<ul style="list-style-type: none"> ■ 1/2"–14 NPT or M20 × 1.5 female conduit ports for outputs and power supply ■ 3/4"–14 NPT female conduit port for sensor/core processor cable ■ Painted aluminum transmitters with WirelessHART, and all stainless steel transmitters, have one additional 1/2"–14 NPT conduit opening 		
Mounting	<ul style="list-style-type: none"> ■ Integral or remote mounting options (stainless steel versions are always remote mounted) ■ May be remotely connected to any 4-wire or 9-wire Micro Motion sensor ■ Remote-mount transmitters: <ul style="list-style-type: none"> ■ Painted aluminum versions include a 304L stainless steel mounting bracket; hardware for installing the transmitter on the mounting bracket is included ■ Stainless steel versions include a 316 stainless steel mounting bracket and hardware ■ Transmitter can be rotated on the sensor or the mounting bracket, 360 degrees, in 90-degree increments. 		
Maximum cable lengths between sensor and transmitter ⁽²⁾	Cable type	Wire gauge	Maximum length
	<ul style="list-style-type: none"> ■ Micro Motion 9-wire 	Not applicable	60 feet (20 meters)
	<ul style="list-style-type: none"> ■ Micro Motion 4-wire 	Not applicable	1000 feet (300 meters)
	<ul style="list-style-type: none"> ■ User-supplied 4-wire power wires (VDC) 	22 AWG (0.34 mm ²)	300 feet (90 meters)
		20 AWG (0.5 mm ²)	500 feet (150 meters)
18 AWG (0.8 mm ²)		1000 feet (300 meters)	
<ul style="list-style-type: none"> ■ User-supplied 4-wire signal wires (RS-485) 	22 AWG (0.34 mm ²) or larger	1000 feet (300 meters)	

Specification	Value
Standard interface/display	<ul style="list-style-type: none"> ■ Segmented 2-line display with LCD screen with optical controls and flowmeter-status LED is standard; suitable for hazardous area installation ■ Available in both backlit and non-backlit versions ■ Depending on purchase option, transmitter housing cover has non-glass or non-glare tempered glass lens ■ To facilitate various mounting orientations, the display can be rotated on transmitter, 360 degrees, in 90-degree increments ■ LCD line 1 lists the process variable; LCD line 2 lists engineering unit of measure ■ Display supports English, French, German, and Spanish languages ■ Display controls feature optical switches that are operated through the glass with a red LED for visual feedback to confirm when a “button” is pressed
Chinese-language interface/display ⁽³⁾	<ul style="list-style-type: none"> ■ Six-line graphical display optimized for Chinese-language support. Has LCD screen with optical controls and flowmeter-status LED; suitable for hazardous area installation ■ Available in both backlit and non-backlit versions ■ Transmitter housing cover has non-glare tempered-glass lens ■ To facilitate various mounting orientations, the display can be rotated on transmitter, 360 degrees, in 90-degree increments ■ Display shows the process variable name, value, and units of measure ■ Display supports English and Chinese languages ■ Display controls feature three optical switches that are operated through the lens with a red LED for visual feedback to confirm when a “button” is pressed. ■ Pressing specific optical switch combinations can access the display menu, change the language display, lock/unlock display access, and return to the process variables view
Display functions ⁽⁴⁾	<ul style="list-style-type: none"> ■ Operational: View process variables; start, stop, and reset totalizers; view and acknowledge alarms. ■ Off-line: Zero flowmeter, Smart Meter Verification, simulate outputs, change measurement units, configure outputs, and set RS-485 communications options. ■ Status LED: Three-color LED status light on display panel indicates flowmeter condition at a glance.

- (1) For transmitters integrally mounted to a sensor, you may need to add the weight of the transmitter to the sensor. Refer to the sensor product data sheet.
- (2) Where 4-wire cable is required, use only Micro Motion 4-wire cable. Depending on the specific model number ordered, 10 ft (3 m) of cable (4-wire or 9-wire) may be included (see ordering information for details). For longer cable lengths, contact customer support.
- (3) This option is available for purchase in China only.
- (4) Applies to all display options.

Model 1500/2500

Weight	0.52 lb (0.24 kg)		
Mounting	<ul style="list-style-type: none"> ■ Mounted on 35 mm rail ■ Rail must be grounded ■ May be remotely connected to any Micro Motion sensor ■ Requires standard 4-wire twisted, shielded signal cable, up to 1000 feet (300 meters) in length, between the sensor and the transmitter. (If the core processor is remotely mounted from the sensor, the maximum length of the 9-wire signal cable between the sensor and the remote core processor is 60 feet [20 meters]) 		
Maximum cable lengths between sensor and transmitter ⁽¹⁾	Cable type	Wire gauge	Maximum length
	■ Micro Motion 9-wire	Not applicable	60 feet (20 meters)
	■ Micro Motion 4-wire	Not applicable	1000 feet (300 meters)

	<ul style="list-style-type: none"> User-supplied 4-wire power wires (VDC) 	22 AWG (0.34 mm ²)	300 feet (90 meters)
		20 AWG (0.5 mm ²)	500 feet (150 meters)
		18 AWG (0.8 mm ²)	1000 feet (300 meters)
	<ul style="list-style-type: none"> User-supplied 4-wire signal wires (RS-485) 	22 AWG (0.34 mm ²) or larger	1000 feet (300 meters)
Status LED	Three-color status LED on face of transmitter indicates flowmeter condition at a glance, using a solid green, yellow, or red light. Zero in progress is indicated by a flashing yellow light		
Zero button	A zero button on the face of the transmitter can be used to start the transmitter zero procedure		

(1) Where 4-wire cable is required, use only Micro Motion 4-wire cable.

Model 1700/2700 4-wire remote-mount transmitter with display – painted aluminum housing

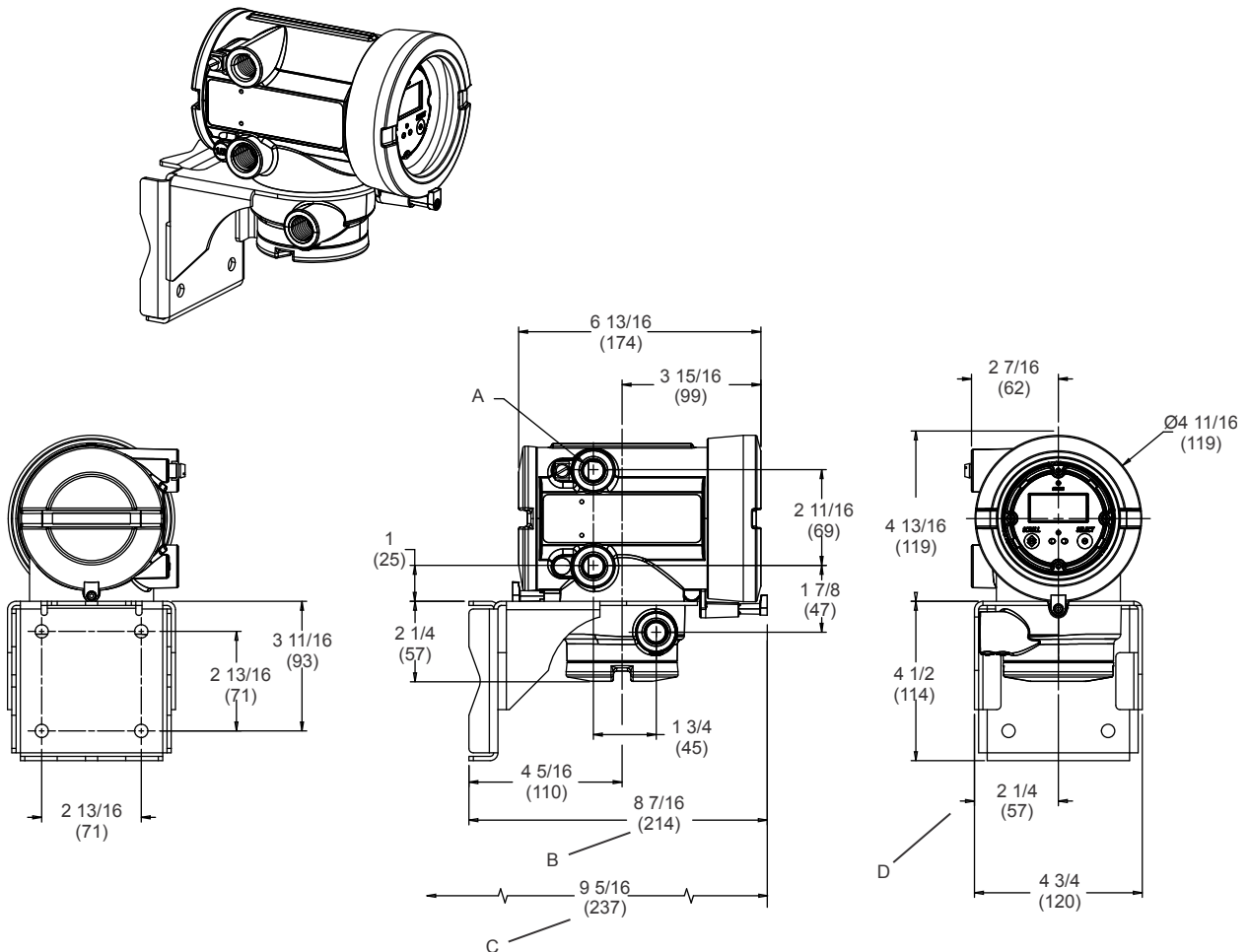

- A. 3 x 1/2"-14 NPT or M20 x 1.5
- B. Wall mount
- C. To centerline of 2 inch (50 mm) pipe (pipe mount)
- D. To conduit opening

Note

Dimensions are in inches (mm).

Model 1700/2700 4-wire remote-mount transmitter without display – painted aluminum housing

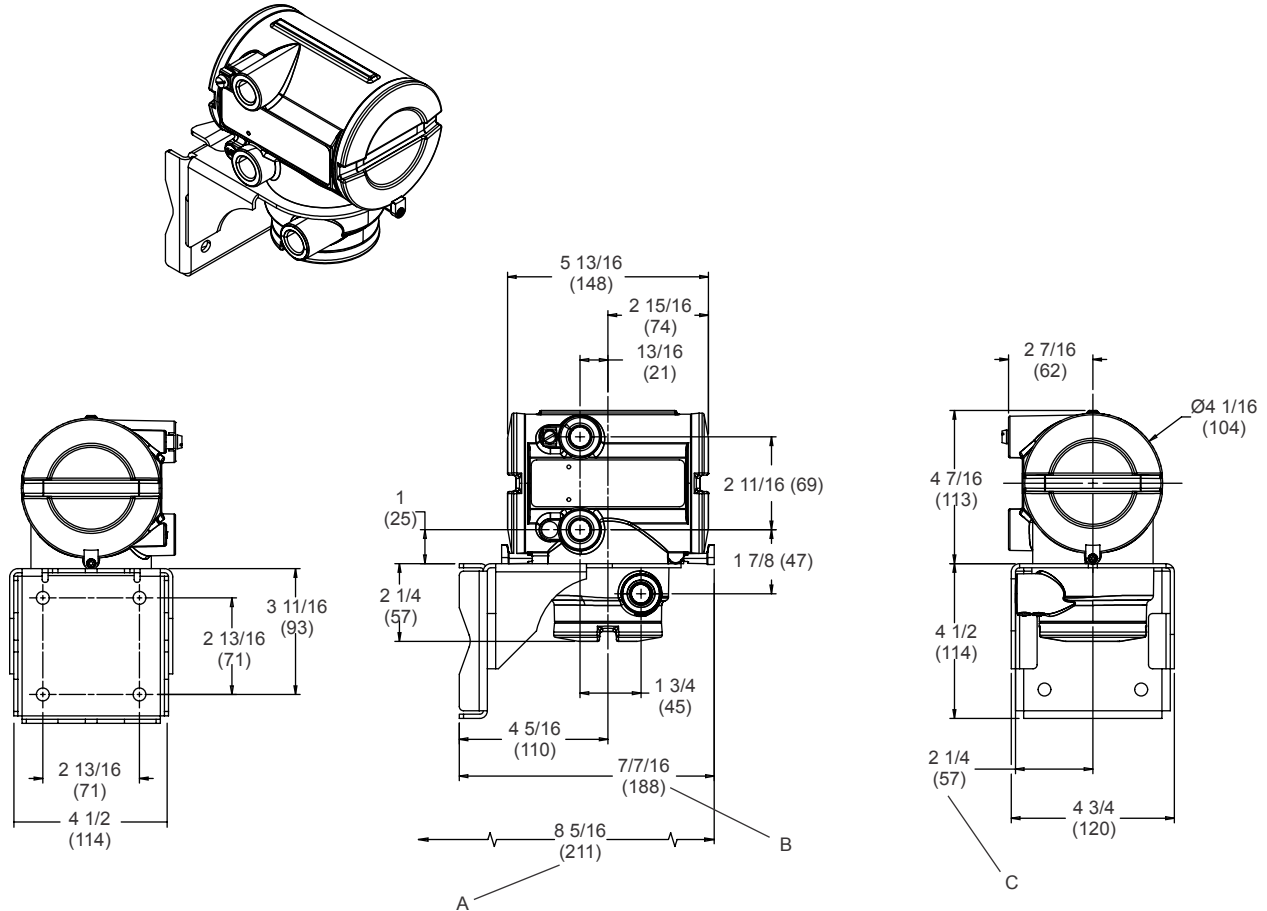

- A. To center line of 2 inch (50 mm) pipe (pipe mount)
- B. Wall mount
- C. To conduit opening

Note

- Dimensions are in inches (mm).
- For integrally-mounted transmitter and sensor dimensions, see the sensor product data sheet.

Model 1700/2700 9-wire remote-mount transmitter and core processor assembly with display – painted aluminum housing

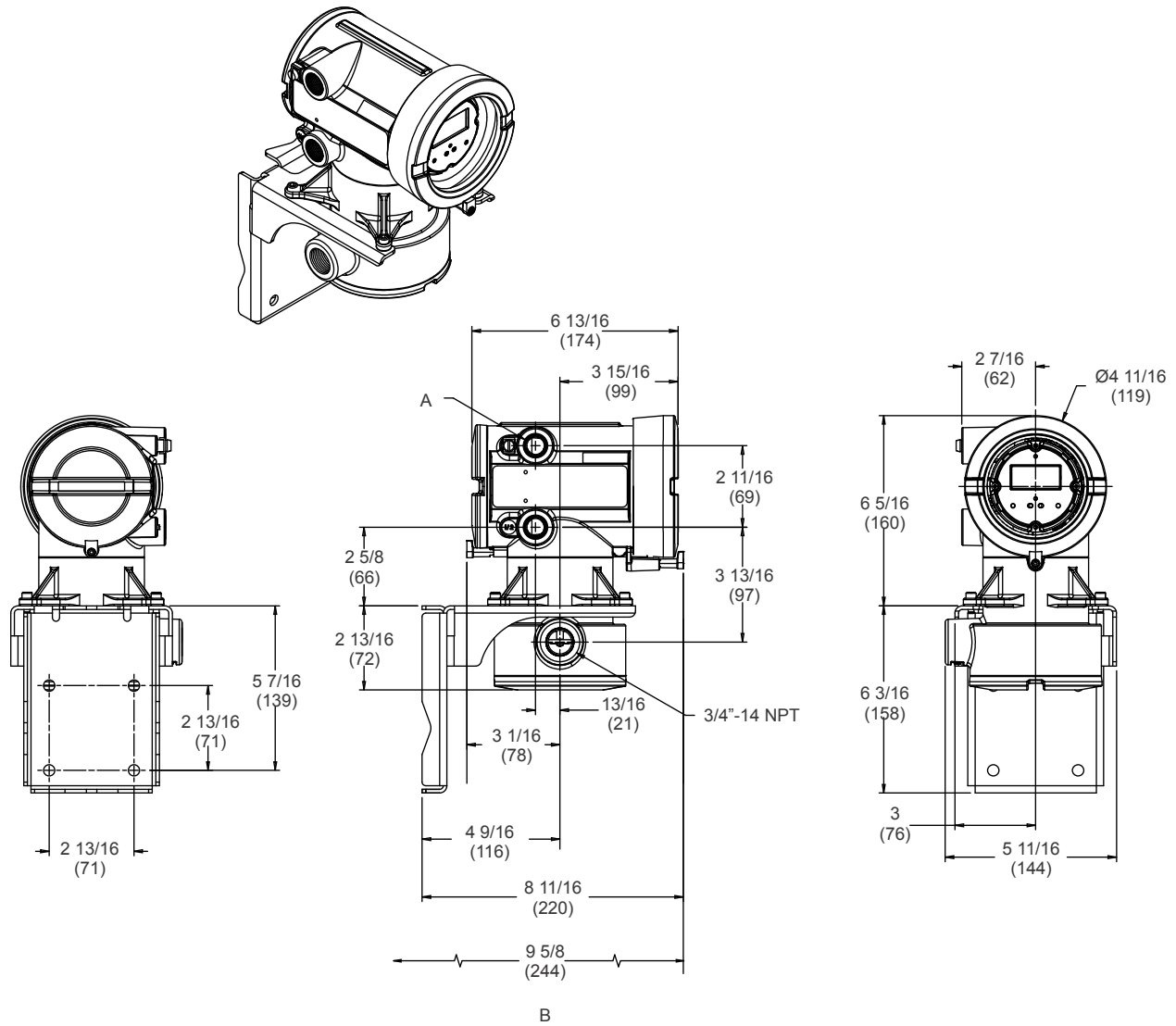

- A. 2 x 1/2 inch-14 NPT or M20 x 1.5
- B. To center line of 2 inches (50 mm) pipe (pipe mount)

Note

- Dimensions are in inches (mm).
- For integrally-mounted transmitter and sensor dimensions, refer to the sensor product data sheet.

Model 1700/2700 9-wire remote-mount transmitter and core processor assembly without display – painted aluminum housing

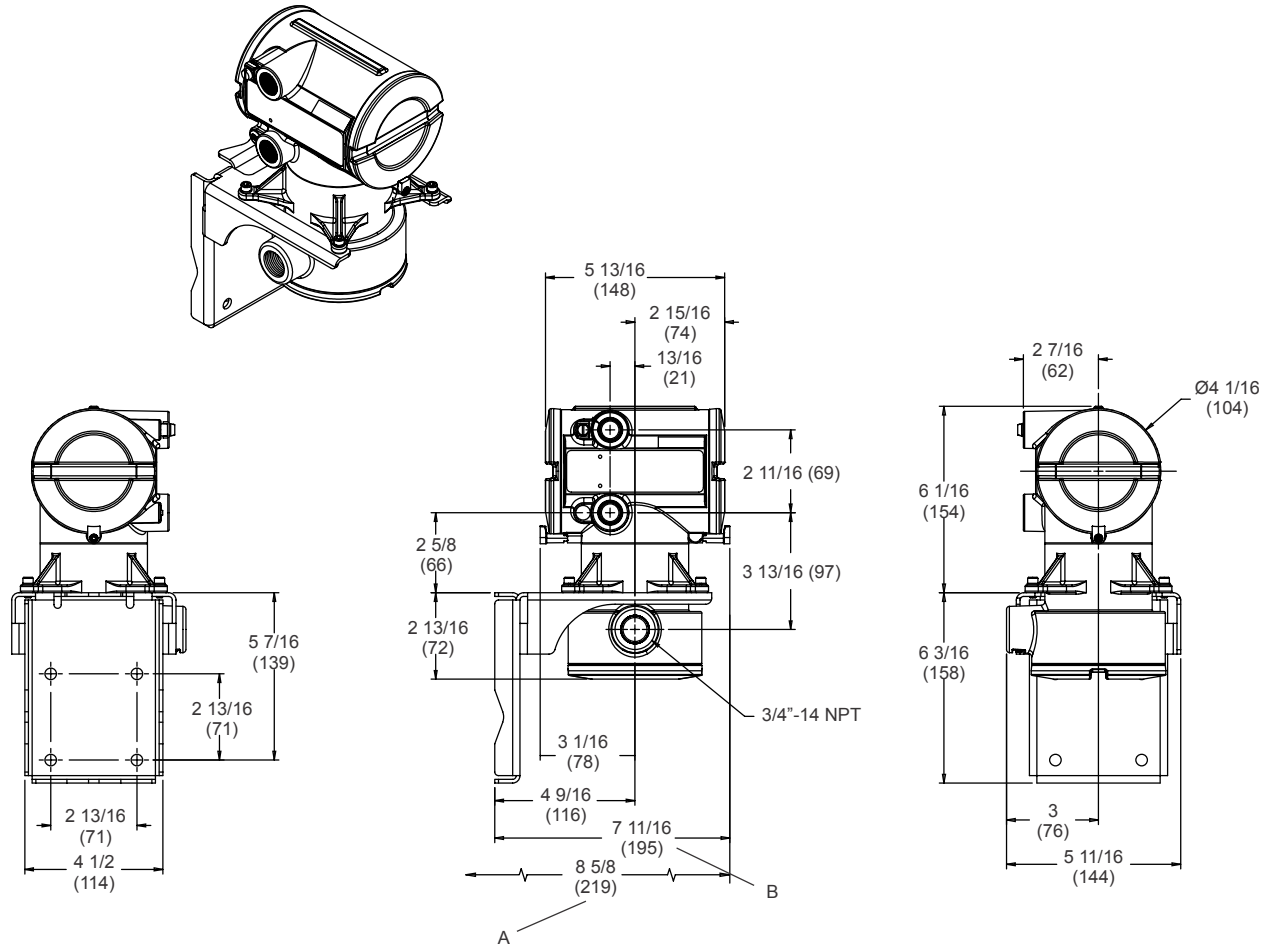

- A. To centerline of 2 inch (50 mm) pipe (pipe mount)
- B. Wall mount

Note

- Dimensions are in inches (mm).
- For integrally-mounted transmitter and sensor dimensions, refer to the sensor product data sheet.

Remote (standard) core processor

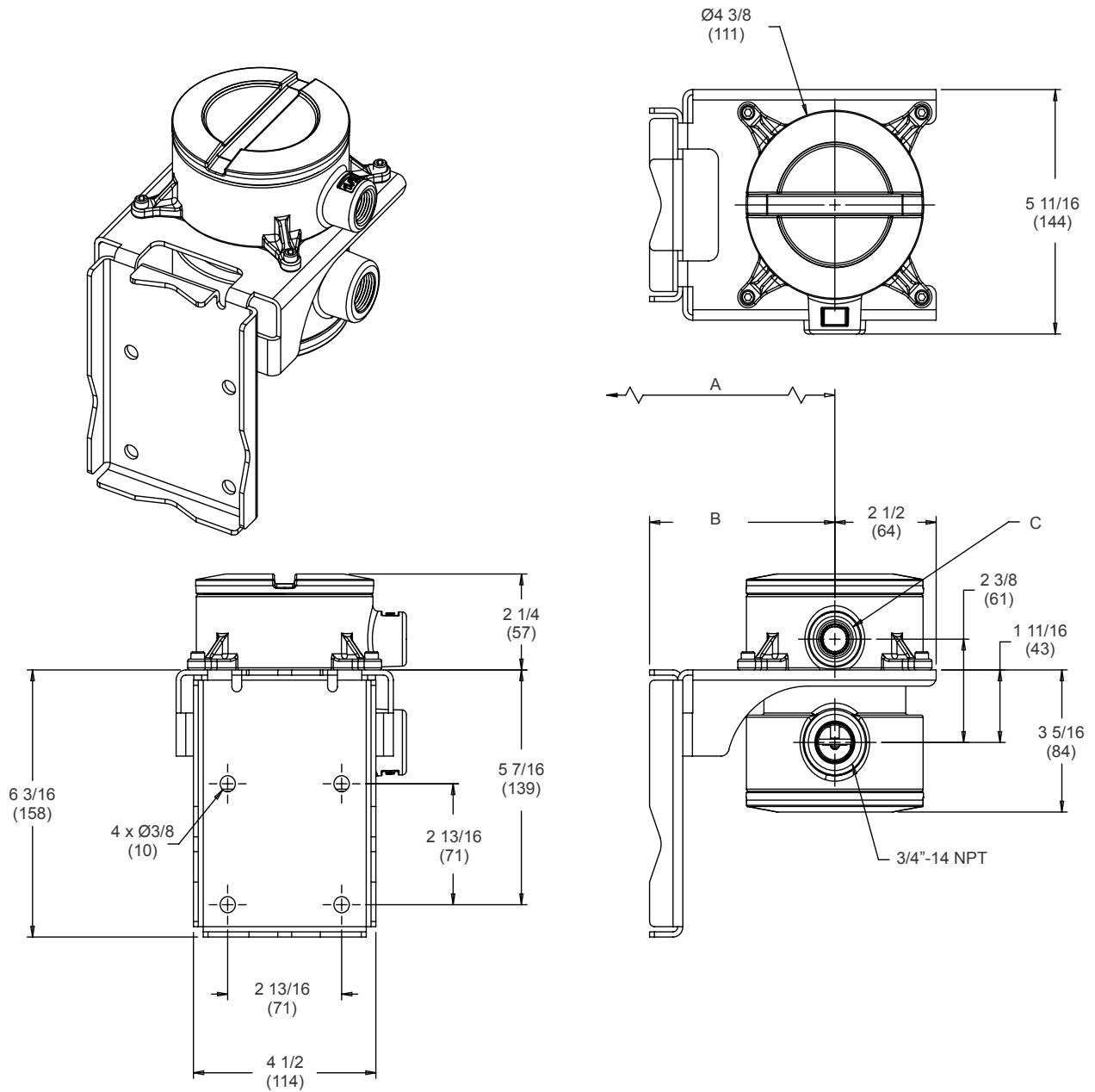

- A. $5 \frac{1}{2}$ inches (140 mm) pipe mount: To center line of 2 inch (50 mm) pipe
- B. $4 \frac{9}{16}$ inches (116 mm) wall mount
- C. $1/2''-14 \text{ NPT}$ or $\text{M}20 \times 1.5$

Note

Dimensions are in inches (mm).

Remote enhanced core processor

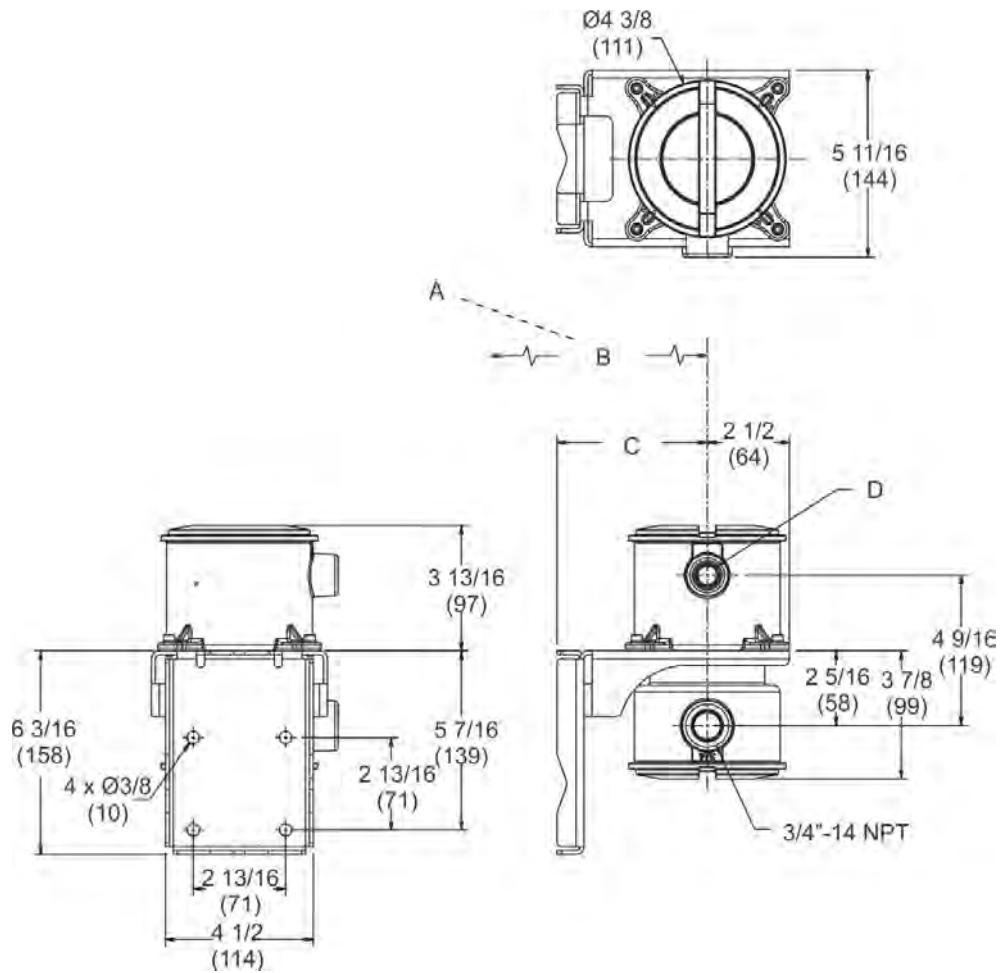

- A. To centerline of 2 inch (50 mm) pipe
- B. $5\ 1/2$ inch (140 mm) pipe mount
- C. $4\ 9/16$ inch (116 mm) wall mount
- D. $1/2$ inch-14 NPT or M20 x 1.5

Note

Dimensions are in inches (mm).

Model 2700 transmitter with Smart Wireless THUM™ Adapter

Output options 2 and 3 (all approval codes) and output option 4 (approval codes E and Z only)

The Model 2700 transmitter with the WirelessHART option provides an additional conduit opening at the top of the transmitter to install the Smart Wireless THUM Adapter. The THUM Adapter comes integrally mounted to the transmitter for output options 2 and 3 (all approval codes) and output option 4 (approval codes E and Z).

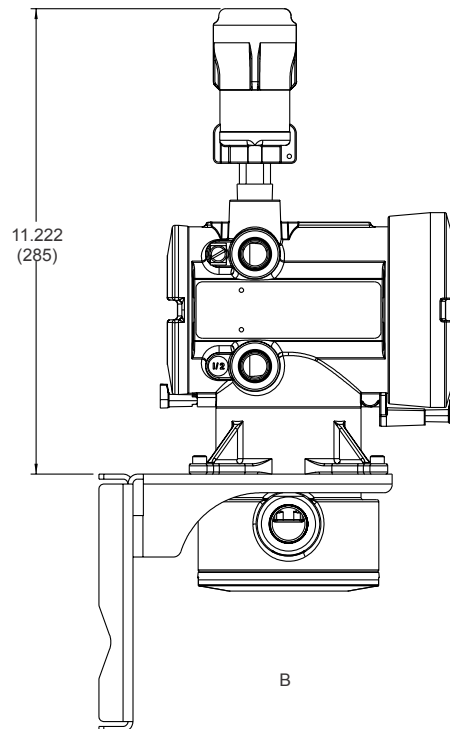
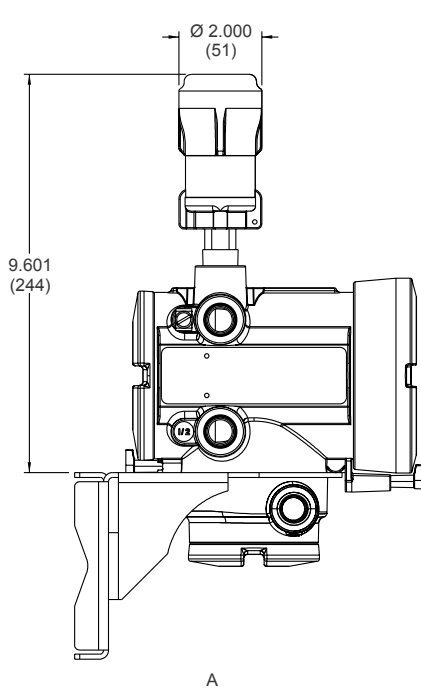
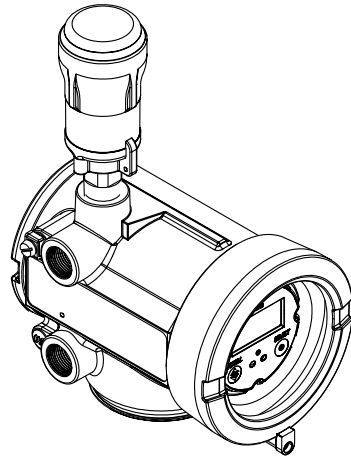

- A. Remote-mount transmitter with integral-mount THUM Adapter
- B. Remote-mount transmitter/core processor assembly with integral-mount THUM Adapter

Note

Dimensions are in inches (mm).

Model 2700 transmitter with Smart Wireless THUM™ Adapter Output option 4 (approval code A)

The Model 2700 transmitter with WirelessHART output option 4 (approval code A) requires using poured conduit seals or a stopping box between the transmitter and Smart Wireless THUM Adapter. The THUM Adapter is not pre-installed for approval code A.

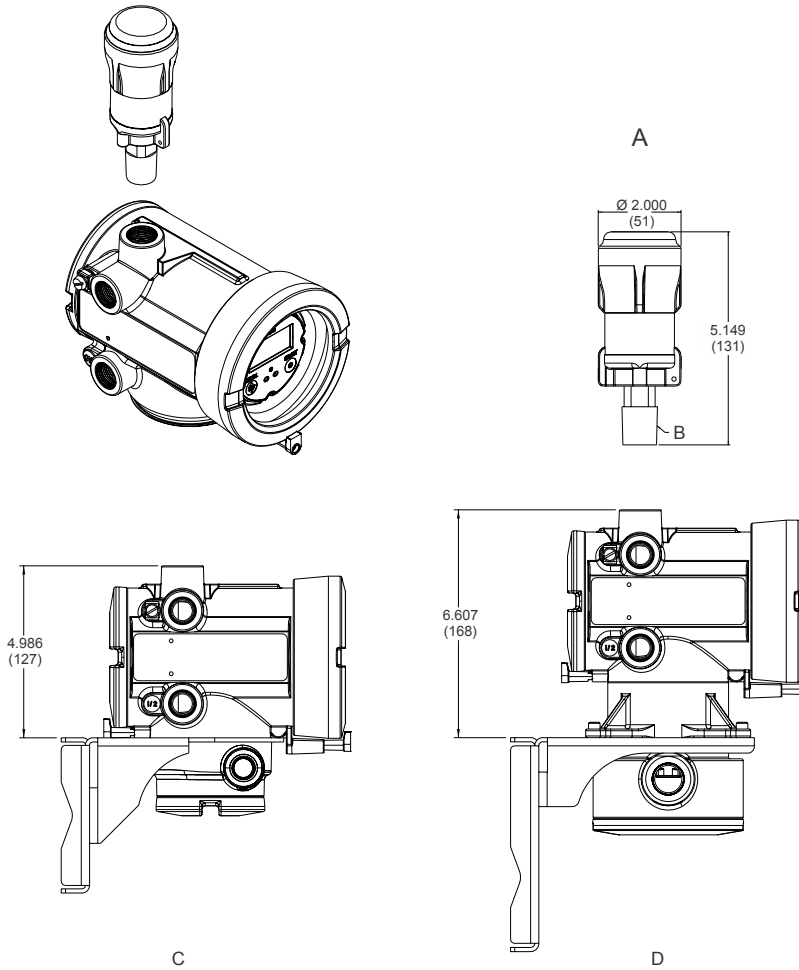

- A. Smart Wireless THUM Adapter
- B. 1/2-14 NPT male
- C. Remote-mount transmitter with additional conduit opening for installation of the THUM Adapter
- D. Remote-mount transmitter/core processor assembly with additional conduit opening for installation of the THUM Adapter

Note

Dimensions are in inches (mm).

Model 1500/2500

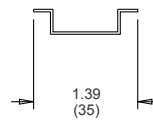
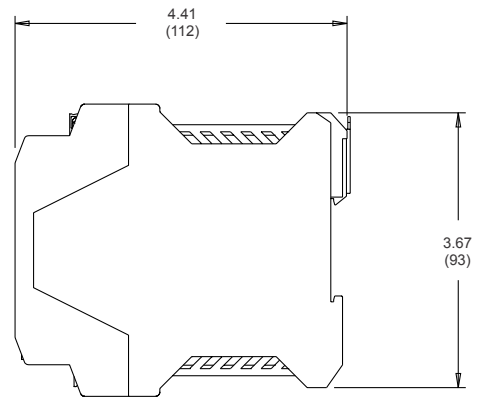
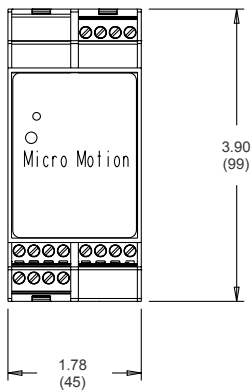
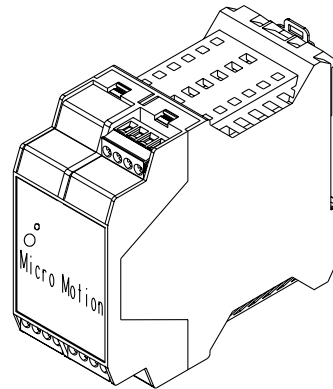
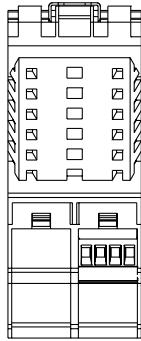

A

A. For mounting on a 35 mm rail

Note

Dimensions are in inches (mm).

Ordering information

Model 1500

Base model

Model	Product description
1500	Micro Motion Coriolis MVD™ 1500 single variable flow transmitter

Mounting

Code	Mounting options for Model 1500
D	4-wire remote 35 mm DIN rail transmitter
E	4-wire remote 35 mm DIN rail transmitter with 9-wire remote enhanced core processor; includes 10 ft. (3m) each 9-wire shielded FEP and 4-wire shielded PVC cable; Available with approval codes M, C, A, B or P only
B	4-wire remote 35 mm DIN rail transmitter with 9-wire remote core processor; includes 10 ft. (3 m) 9-wire shielded FEP cable

Power

Code	Power options for Model 1500
3	19.2 to 28.8 VDC

Conduit connection

Code	Conduit connection options for Model 1500 – with mounting code D
A	None

Code	Conduit connection options for Model 1500 – with mounting code B or E
B	1/2-inch NPT remote core processor – no gland
E	M20 remote core processor – no gland
F	Remote core processor – brass/nickel cable gland Not available with approval code S, T, or J
G	Remote core processor – stainless steel cable gland Not available with approval code S, T, or J
K	JIS B0202 1/2G – no gland Only available with approval code M, T, or S
L	Japan - brass nickel cable gland Only available with approval code M, T, or S
M	Japan - stainless cable gland Only available with approval code M, T, or S

Output

Code	Output options for Model 1500
A	One mA, one frequency, RS-485 Not available with software option 1 code B
C	One mA, two DO, RS-485 Only available with software 1 code B

Terminal

Code	Terminal options for Model 1500
B	Screw terminals

Approval

Code	Approval options for Model 1500
M	Micro Motion Standard (no approval, with CE/EAC mark)
C	CSA (Canada only)
A	CSA (US and Canada)
B	ATEX - Safe area with IS sensor outputs
P	NEPSI – Safe area Only available with language code M (Chinese)
T	TIIS - IIC sensor (not available for quotes outside of Japan) Available for quote only.
S	TIIS - IIB sensor (not available for quotes outside of Japan) Available for quote only.
J	Hardware ready for TIIS approval (EPM Japan only) Approval Code J is only available with Conduit Connections Option E; Available for order only
G	Country Specific Approval - Requires a selection from the Approvals section of the "Add on Options"

Language

Code	Language options for Model 1500
A	Danish CE requirements document; English installation and configuration manuals
D	Dutch CE requirements document; English installation and configuration manuals
E	English installation manual; English configuration manual
F	French installation manual; French configuration manual
G	German installation manual; German configuration manual
H	Finnish CE requirements document; English installation and configuration manuals
I	Italian installation manual; English configuration manual
J	Japanese installation manual; Japanese configuration manual
M	Chinese installation manual; Chinese configuration manual

Code	Language options for Model 1500
N	Norwegian CE requirements document; English installation and configuration manuals
O	Polish installation manual; English configuration manual
P	Portuguese installation manual; English configuration manual
S	Spanish installation manual; Spanish configuration manual
W	Swedish CE requirements document; English installation and configuration manuals
C ⁽¹⁾	Czech CE requirements document, English installation and configuration manuals
B ⁽¹⁾	Hungarian CE requirements document; English installation and configuration manuals
K ⁽¹⁾	Slovak CE requirements document; English installation and configuration manuals
T ⁽¹⁾	Estonian CE requirements document; English installation and configuration manuals
U ⁽¹⁾	Greek CE requirements document; English installation and configuration manuals
L ⁽¹⁾	Latvian CE requirements document; English installation and configuration manuals
V ⁽¹⁾	Lithuanian CE requirements document; English installation and configuration manuals
Y ⁽¹⁾	Slovenian CE requirements document; English installation and configuration manuals

(1) Not available with approval code J, T, or S.

Software 1

Code	Software options 1 for Model 1500
Z	Flow variable (standard)
B	Filling and dosing application Not available with Output code A.
J	Production Volume Reconciliation Available with software option 2 codes Z and C only
K	Transient Mist Remediation Available with software option 2 codes Z and C only
L	Transient Bubble Remediation Available with software option 2 codes Z and C only
R	Piece-wise linearization for gas Available with software option 2 codes Z and C only
X	ETO software option 1 Requires "X" Factory option code

Software 2

Code	Software options 2 for Model 1500
Z	No software options 2
C	Smart Meter Verification Not available with Mounting Option B; Smart Meter Verification is not available with all sensors.

Code	Software options 2 for Model 1500
X	ETO software option 2 Requires "X" Factory option code

Factory

Code	Factory options for Model 1500
Z	Standard product
X	ETO product

Add on Options

Code	Add on options for Model 1500
	Country specific approval (select one from the following if approval code G is selected):
R4	EAC Safe Area Only with IS Sensor Outputs - Hazardous Area Approval
B4	INMETRO Safe Area Only with IS Sensor Outputs - Hazardous Area Approval

Model 1700

Base model

Model	Product description
1700	Micro Motion Coriolis MVD Model 1700 single variable flow transmitter

Mounting

Code	Mounting options for Model 1700
R	4-wire remote mount transmitter (polyurethane-painted aluminum housing) includes 10 ft. [3m] 4 wire shielded PVC cable)
I	Integral mount transmitter (polyurethane-painted aluminum housing)
E	4-wire remote mount transmitter with 9-wire remote enhanced core processor; includes 10 ft. (3 m) each of 4-wire shielded PVC cable and 9-wire shielded FEP cable Not available with conduit connection code C or D; Not available with approval option codes S or T with conduit connections L or M
B	4-wire remote mount transmitter with 9-wire remote core processor; includes 10 ft. (3 m) each of 4-wire shielded PVC cable and 9-wire shielded FEP cable Not available with conduit connection code C or D
C	9-wire remote transmitter with integral core processor (polyurethane-painted aluminum housing) includes 10 ft. [3m] CFEPS cable
M	4-wire remote mount transmitter with stainless steel housing; includes 10 ft. (3m) 4-wire shielded PVC cable; Not available with Approval codes U, Z, P, K, T, S, J or G with country-specific approval codes R1 or B1.

Code	Mounting options for Model 1700
P	9-wire remote mount transmitter with stainless steel housing and integral core processor; includes 10 ft. (3m) CFEPs cable Not available with Approval codes U, Z, P, K, T, S, J or G with country-specific approval codes R1 or B1.

Power

Code	Power options for Model 1700
1	18 to 100 VDC or 85 to 265 VAC; self switching

Display

Code	Display options for Model 1700
1	Dual line display for CSA, UL, and IIB + H2 ATEX, IECEx and NEPSI ratings Not available with mounting code M or P
2	Backlit dual line display for CSA, UL, and IIB + H2 ATEX, IECEx and NEPSI ratings
3	No display Not available with approval codes J, T, or S
5	Backlit dual line display for IIC ATEX, IECEx, and NEPSI rating Only available with approval codes Z, F, P, K, I or G with country specific approval R1, B1, R2, B2
7	Non-glass backlit dual line display for General Purpose (no approvals) Only available with approval code M; Not available with either mounting code M or P
8	Display optimized for Chinese-language support; China only Available with Mounting Option codes R, I, C, or B; Output code A; Conduit Connections codes B, C, D, E, F or G; Approval codes M, Z, F, P, K, I or G with country specific approval codes R1, B1, R2, or B2; Language codes E or M; Software 2 Options Z or C; Factory Option Z.

Output

Code	Output options for Model 1700
A	Analog outputs: one mA; one frequency; RS-485
D	Intrinsically safe analog outputs: one mA, one frequency Not available with approval code T, S, or J

Conduit connection

Code	Conduit connection options for Model 1700
B	1/2-inch NPT – no gland Not available with approval code T, S, or J
C	1/2-inch NPT with brass nickel cable gland (not approved for Class 1 Division 1 installations) Not available with approval code T, S, or J; Not available with mounting codes B, E, M, or P
D	1/2-inch NPT with stainless-steel cable gland (not approved for Class 1 Division 1 installations) Not available with approval code T, S, or J; Not available with mounting code B or E.

Code	Conduit connection options for Model 1700
E	M20 – no gland Not available with approval code T or S
F	M20 with brass nickel cable gland (not approved for Class 1 Division 1 installations) Not available with mounting code M or P
G	M20 with stainless steel cable gland (not approved for Class 1 Division 1 installations)
K	JIS B0202 1/2G – no gland; Only available with approval code M; Not available with mounting code M or P
L	Japan - brass nickel cable gland; Only available with approval code M, T, or S; Not available with mounting code M or P
M	Japan - stainless-steel cable gland; Only available with approval code M, T, or S; Not available with mounting code M or P

Approval

Code	Approval options for Model 1700
M	Micro Motion Standard (no approval, with CE/EAC mark)
U	UL Only available with conduit connection code B or E
C	CSA (Canada only)
A	CSA (US and Canada)
Z	ATEX – Equipment Category 2 (Zone 1 – Increased safety terminal compartment)
F	ATEX – Equipment Category 2 (Zone 1 – Flameproof terminal compartment)
P	NEPSI – Equipment Category 2 (Zone 1 – Flameproof terminal compartment) Only available with language code M (Chinese)
K	NEPSI – Equipment Category 2 (Zone 1 – Increased safety terminal compartment) Only available with language code M (Chinese)
I	IECEx Equipment Category 2 (Zone 1 – Flameproof terminal compartment)
T	TIIS - IIC sensor (not available for quotes outside of Japan) Available for quote only
S	TIIS - IIB sensor (not available for quotes outside of Japan) Available for quote only
J	Hardware ready for TIIS approval (EPM Japan only) Approval code J is only available with Conduit Connections Option E; Available for order only
G	Country Specific Approval - Requires a selection from the Approvals section of the Add on Option

Language

Code	Language options for Model 1700
A	Danish CE requirements document; English installation and configuration manuals
D	Dutch CE requirements document; English installation and configuration manuals
E	English installation manual; English configuration manual
F	French installation manual; French configuration manual
G	German installation manual; German configuration manual
H	Finnish CE requirements document; English installation and configuration manuals
I	Italian installation manual; English configuration manual
J	Japanese installation manual; Japanese configuration manual
M	Chinese installation manual; Chinese configuration manual
N	Norwegian CE requirements document; English installation and configuration manuals
O	Polish installation manual; English configuration manual
P	Portuguese installation manual; English configuration manual
S	Spanish installation manual; Spanish configuration manual
W	Swedish CE requirements document; English installation and configuration manuals
C	Czech CE requirements: English installation and configuration manuals
B	Hungarian CE requirements document; English installation and configuration manuals
K	Slovak CE requirements document; English installation and configuration manuals
T	Estonian CE requirements document; English installation and configuration manuals
U	Greek CE requirements document; English installation and configuration manuals
L	Latvian CE requirements document; English installation and configuration manuals
V	Lithuanian CE requirements document; English installation and configuration manuals
Y	Slovenian CE requirements document; English installation and configuration manuals

Software 1

Code	Software options 1 for Model 1700
Z	Flow variable (standard)
J	Production volume reconciliation Available with software option 2 Z and C only
K	Transient mist remediation Available with software option 2 Z and C only
L	Transient bubble remediation Available with software option 2 Z and C only
R	Piece-wise linearization for gas Available with software option 2 Z and C only

Software 2

Code	Software options 2 for Model 1700
Z	No software options 2
C	Smart Meter Verification Not available with Mounting Option I, B, C, or P; Smart Meter Verification is not available with all sensors.
S	Safety certification of 4–20 mA output per IEC 61508 Only available with output code A or D
V	Safety Certification per IEC 61508 with Smart Meter Verification Not available with Mounting Option I, B, C, or P; Smart Meter Verification is not available with all sensors. Only available with output code A or D

Factory

Code	Factory options for Model 1700
Z	Standard product
X	ETO product

Add on Options

Code	Add on options for Model 1700
CL	Hardware for cover lockout Hardware only; does not include weight & measures software
PK	2-inch pipe mount U-bolt kit for electronics Not available with Mounting Option I Country specific approval (select one from the following if approval code G is selected)
R1	EAC Zone 2 - Hazardous Area Approval - Increased safety terminal compartment (Exe)
R2	EAC Zone 1 - Hazardous Area Approval - Flameproof terminal compartment
B1	INMETRO Zone 1 - Hazardous Area Approval - Increased safety terminal compartment
B2	INMETRO Zone 1 - Hazardous Area Approval - Flameproof terminal compartment

Model 2500

Base model

Model	Product description
2500	Micro Motion Coriolis MVD™ 2500 multivariable flow and density transmitter

Mounting

Code	Mounting options for Model 2500
D	4-wire remote 35 mm DIN rail transmitter
E	4-wire 35 mm DIN rail transmitter with 9-wire remote enhanced core processor; includes 10 ft. (3m) each 9-wire shielded FEP and 4-wire shielded PVC cable Available with approval options M, C, A, B or P only
B	4-wire remote 35 mm DIN rail transmitter with 9-wire remote core processor; includes 10 ft. (3 m) 9-wire shielded FEP cable

Power

Code	Power options for Model 2500
3	19.2 to 28.8 VDC

Conduit connection

Code	Conduit connection options for Model 2500 — with mounting code D
A	None

Code	Conduit connection options for Model 2500 — with mounting code B or E
B	1/2-inch NPT remote core processor – no gland
E	M20 remote core processor – no gland
F	Remote core processor – brass/nickel cable gland Not available with approval code S, T, or J
G	Remote core processor – stainless steel cable gland Not available with approval code S, T, or J
K	JIS B0202 1/2G – no gland; Only available with approval code M, T, or S
L	Japan - brass nickel cable gland; Only available with approval code M, T, or S
M	Japan - stainless cable gland; Only available with approval code M, T, or S

Output

Code	Output options for Model 2500
B	One mA, two configurable I/O channels, RS-485 – default configuration of two mA, one FO
C	One mA, two configurable I/O channels, RS-485 – custom configuration

Terminal

Code	Terminal options for Model 2500
B	Screw terminals

Approval

Code	Approval options for Model 2500
M	Micro Motion Standard (no approval, with CE/EAC mark)
C	CSA (Canada only)
A	CSA (US and Canada)
B	ATEX - Safe area with IS sensor outputs
P	NEPSI – Safe area Only available with language code M (Chinese)
T	TIIS - IIC sensor (not available for quotes outside of Japan) Available for quote only
S	TIIS - IIB sensor (not available for quotes outside of Japan) Available for quote only
J	Hardware ready for TIIS approval (EPM Japan only) Approval code J is only available with Conduit Connections Option E; Available for order only.
G	Country Specific Approval - Requires a selection from the Approvals section of the Add on Options

Language

Code	Language options for Model 2500
A	Danish CE requirements document; English installation and configuration manuals
D	Dutch CE requirements document; English installation and configuration manuals
E	English installation manual; English configuration manual
F	French installation manual; French configuration manual
G	German installation manual; German configuration manual
H	Finnish CE requirements document; English installation and configuration manuals
I	Italian installation manual; English configuration manual
J	Japanese installation manual; Japanese configuration manual
M	Chinese installation manual; Chinese configuration manual
N	Norwegian CE requirements document; English installation and configuration manuals
O	Polish installation manual; English configuration manual
P	Portuguese installation manual; English configuration manual

Code	Language options for Model 2500
S	Spanish installation manual; Spanish configuration manual
W	Swedish CE requirements document; English installation and configuration manuals
C ⁽¹⁾	Czech installation manual; English installation and configuration manuals
B ⁽¹⁾	Hungarian CE requirements document; English installation and configuration manuals
K ⁽¹⁾	Slovak CE requirements document; English installation and configuration manuals
T ⁽¹⁾	Estonian CE requirements document; English installation and configuration manuals
U ⁽¹⁾	Greek CE requirements document; English installation and configuration manuals
L ⁽¹⁾	Latvian CE requirements document; English installation and configuration manuals
V ⁽¹⁾	Lithuanian CE requirements document; English installation and configuration manuals
Y ⁽¹⁾	Slovenian CE requirements document; English installation and configuration manuals

(1) Not available with approvals code J, T, or S.

Software 1

Code	Software options 1 for Model 2500
Z	Flow and density variables (standard)
G	Concentration measurement Not available with approval code S, T or J
A	Petroleum measurement
J	Production Volume Reconciliation Available with Software Option 2 Z and C only
K	Transient Mist Remediation Available with Software Option 2 Z and C only
L	Transient Bubble Remediation Available with Software Option 2 Z and C only
M	Fuel consumption Available with Software Option 2 Z and C only
Q	Transient Bubble Remediation and petroleum measurement Available with Software Option 2 Z and C only
R	Piece-wise linearization for gas Available with Software Option 2 Z and C only
X	ETO software option 1 Requires factory code X

Software 2

Code	Software options 2 for Model 2500
Z	No software options 2
C	Smart Meter Verification Not available with Mounting Option B; Smart Meter Verification is not available with all sensors.
W	Weights and measures custody transfer (requires user-provided external sealing for approval)
D	Weights and measures custody transfer & Smart Meter Verification (requires user-provided external sealing) Not available with Mounting Option B; Smart Meter Verification is not available with all sensors.
X	ETO software option 2 Requires factory code X

Factory

Code	Factory options for Model 2500
Z	Standard product
X	ETO product

Add on Options

Code	Add on options for Model 2500
	Country specific approval (select one from the following if approval code G is selected):
R4	EAC Safe Area Only with IS Sensor Outputs - Hazardous Area Approval
B4	INMETRO Safe Area Only with IS Sensor Outputs - Hazardous Area Approval

Model 2700

Base model

Model	Product description
2700	Micro Motion Coriolis MVD Model 2700 multivariable flow and density transmitter

Mounting

Code	Mounting options for Model 2700
R	4-wire remote mount transmitter (polyurethane-painted aluminum housing) includes 10 ft. [3m] 4 wire shielded PVC cable
I	Integral mount transmitter (polyurethane-painted aluminum housing)
E	4-wire remote mount transmitter with 9-wire remote enhanced core processor; includes 10 ft. (3 m) each of 4-wire shielded PVC cable and 9-wire shielded FEP cable; Mounting code B, E not available with conduit connection code C or D; Available with approval options M, C, A, F, Z, P or I only; Not available with approval option codes S or T or with Conduit Connections L or M.
B	4-wire remote mount transmitter with 9-wire remote core processor (polyurethane-painted aluminum housing) includes 10 ft. [3m] each 9 wire shielded FEP and 4 wire shielded PVC cable Mounting code B, E not available with conduit connection code C or D
C	9-wire remote transmitter with integral core processor (polyurethane-painted aluminum housing) includes 10 ft. [3m] CFEPs cable Mounting codes M and P are not available with approval codes U, Z, P, K, T, S, J, E or G with country-specific approval codes R1 and B1;
M	4-wire remote mount transmitter with stainless steel housing; includes 10 ft. (3 m) 4-wire shielded PVC cable; Mounting codes M and P are not available with approval codes U, Z, P, K, T, S, J, E or G, with country-specific approval R1 or B1; Mounting codes M and P are not available with Output codes 2 and 3 because the SS housing is not Zone 1 increased safety (Ex e) approved.
P	9-wire remote mount transmitter with stainless steel housing and integral core processor; includes 10 ft. (3m) CFEPs cable Mounting codes M and P are not available with approval codes U, Z, P, K, T, S, J, E or G, with country-specific approval R1 or B1; Mounting codes M and P are not available with Output codes 2 and 3 because the SS housing is not Zone 1 increased safety (Ex e) approved.
H	4-wire remote mount transmitter (polyurethane-painted aluminum housing) for connecting to CDM/FDM/FVM meters [power and communications] includes 10ft (3m) 4 wire shielded PVC cable Not available with approval codes J, T or S

Power

Code	Power options for Model 2700
1	18 to 100 VDC or 85 to 265 VAC; self switching

Display

Code	Display options for Model 2700
1	Dual line display for CSA, UL, and IIB + H2 ATEX, IECEx and NEPSI ratings; Not available with mounting codes M, P; or H
2	Backlit dual line display for CSA, UL, and IIB + H2 ATEX, IECEx and NEPSI ratings
3	No display Not available with approval codes J, T, or S
5	Backlit dual line display for IIC ATEX, IECEx, and NEPSI rating Only available with approval codes Z, F, P, K, I, E, L, or 3

Code	Display options for Model 2700
7	Backlit dual line display for process variables and totalizer reset, non-glass lens Only available with approval code M; not available with mounting codes M, H, or P
8	Display optimized for Chinese-language support; China only Only available with mounting code R, I, C, or B, output code A, conduit connection code B, C, D, E, F or G, and approval code M, Z, F, P, K, I, or G code with country specific approval R1, R2, B1, B2

Output

Code	Output options for Model 2700
A	Analog outputs: one mA; one frequency; RS-485 Not available with mounting code H
B	One mA; two configurable IO channels - default configuration of 2 mA, 1 FO Not available with mounting code H
C	One mA; two configurable IO channels - custom configuration Not available with mounting code H
D	Intrinsically safe analog outputs: two mA, one frequency; Not available with mounting code H; Output code D and E are not available with approval codes T, S, and J.
E	Foundation fieldbus intrinsically safe H1 with standard function blocks (4 x AI, 1 x AO, 1 x integrator, 1 x DI, 1 x DO) Output code D and E are not available with approval codes T, S, and J; Output code E is not available with approval code U, 2, L, 3 or G with country specific approval codes R3 or B3
G	PROFIBUS-PA; not available with approval codes U, 2, L and 3 Output code G not available with approval codes U, 2, L, 3 or G with country-specific approval option R3, B3; not available with mounting code H:
N	Foundation Fieldbus H1 with standard function blocks (4 x AI, 1 x AO, 1 x integrator, 1 x DI, 1 x DO); Output code N is not available with approval codes U, C, A, E, 2, L, 3 or G with country-specific approval R3, B3
2	One mA; one frequency; RS485; Wireless HART ready; order 775 with 1/2" NPT mounting option Not available with mounting code H; output codes 2 and 3 are only available with approval codes M, 2, L, 3, G with country-specific approval R3, B3.
3	One mA; two configurable IO channels - custom configuration; Wireless HART ready; order 775 with 1/2" NPT mounting option Not available with approvals J, T or S; not available with mounting code H; output codes 2 and 3 are only available with approval codes M, 2, L, 3, G with country-specific approval R3, B3.
4	Intrinsically safe outputs; two mA; one frequency; Wireless HART ready; order 775 with 1/2" NPT mounting option Not available with mounting code H; output code 4 is only available with approval codes E, Z, A, or G with country-specific approval R1, B1 when using stopping box

Conduit connection

Code	Conduit connection options for Model 2700									
	Available with mounting codes:	R	I	B	E	C	M	P	H	
B	1/2-inch NPT – no gland; Not available with approval code T, S, or J	•	•	•	•	•	•	•	•	•
	Only available with mounting code R, I, B, E, C, M, or P:									
C	1/2-inch NPT with brass nickel cable gland (not approved in Class 1 Division 1 installations) Not available with approval code T, S, or J; mounting code B, E not available with Conduit Connection C or D; not available with mounting code M, or P	•	•			•				
D	1/2-inch NPT with stainless steel cable gland (not approved in Class 1 Division 1 installations) Not available with approval codes J, T, or S; mounting codes B or E not available with Conduit Connection codes C or D	•	•			•	•	•		
E	M20 – no gland Not available with approvals T or S	•	•	•	•	•	•	•		
F	M20 with brass nickel cable gland (not approved in Class 1 Division 1 installations) Not available with mounting code M or P	•	•	•	•	•				
G	M20 with stainless steel cable gland (not approved in Class 1 Division 1 installations)	•	•	•	•	•	•	•		
K	JIS B0202 1/2G – no gland Only available with approval code M; not available with mounting code M or P	•	•	•	•	•				
L	Japan - brass nickel cable gland Only available with approval codes M, T, or S; not available with mounting code M or P	•	•	•	•	•				
M	Japan - stainless cable gland Only available with approval codes M, T, or S; not available with mounting code M or P	•	•	•	•	•				

Approval

Code	Approval options for Model 2700
M	Micro Motion Standard (no approval, with CE/EAC mark)
U	UL Approval code U is available with conduit codes B or E only.
C	CSA (Canada only)
A	CSA C-US (US and Canada)
Z	ATEX - Equipment Category 2 (Zone 1 - Increased safety terminal compartment)
F	ATEX - Equipment Category 2 (Zone 1 - Flameproof terminal compartment)

Code	Approval options for Model 2700
P	NEPSI – Equipment Category 2 (Zone 1 – Flameproof terminal compartment); Available with Chinese (M) language option only
K	NEPSI – Equipment Category 2 (Zone 1 – Increased safety terminal compartment) Available with Chinese (M) language option only
I	IECEX Equipment Category 2 (Zone 1 – Flameproof terminal compartment)
T	TIIS - IIC sensor (not available for quotes outside of Japan) Available for quote only
S	TIIS - IIB sensor (not available for quotes outside of Japan) Available for quote only
J	Hardware ready for TIIS approval (EPM Japan only) Approval code J is only available with Conduit Connections Option E; Available for order only
E	IECEX (Zone 1 - Increased safety terminal compartment) Only available with output code 4
2	CSA Class 1 Div. 2 (US and Canada) Sensor connections will be intrinsically Safe without additional barrier
L	ATEX - Equipment Category 3 (Zone 2) Sensor connections will be intrinsically Safe without additional barrier; Approval code L is only available with output options 2 and 3.
3	IECEX (Zone 2) Sensor connections will be intrinsically Safe without additional barrier
G	Country Specific Approval - Requires a selection from the Approvals section of the Add on Options

Language

Code	Language options for Model 2700
A	Danish CE requirements document; English installation and configuration manuals
D	Dutch CE requirements document; English installation and configuration manuals
E	English installation manual; English configuration manual
F	French installation manual; French configuration manual
G	German installation manual; German configuration manual
H	Finnish CE requirements document; English installation and configuration manuals
I	Italian installation manual; English configuration manual
J	Japanese installation manual; Japanese configuration manual
M	Chinese installation manual; Chinese configuration manual
N	Norwegian CE requirements document; English installation and configuration manuals
O	Polish installation manual; English configuration manual
P	Portuguese installation manual; English configuration manual
S	Spanish installation manual; Spanish configuration manual
W	Swedish CE requirements document; English installation and configuration manuals

Code	Language options for Model 2700
C	Czech CE requirements document; English installation and configuration manuals
B	Hungarian CE requirements document; English installation and configuration manuals
K	Slovak CE requirements document; English installation and configuration manuals
T	Estonian CE requirements document; English installation and configuration manuals
U	Greek CE requirements document; English installation and configuration manuals
L	Latvian CE requirements document; English installation and configuration manuals
V	Lithuanian CE requirements document; English installation and configuration manuals
Y	Slovenian CE requirements document; English installation and configuration manuals

Software 1

Code	Software options 1 — only available with mounting codes R, I, B, E, C, M, and P
Z	Flow and density variables (standard)
G	Concentration measurement
A	Petroleum measurement
J	Production Volume Reconciliation Approval code J is only available with conduit connections option E.
K	Transient Mist Remediation Approval code J is only available with conduit connections option E.
L	Transient Bubble Remediation Approval code J is only available with conduit connections option E.
M	Fuel consumption Approval code J is only available with conduit connections option E.
Q	Transient Bubble Remediation and petroleum measurement Approval code J is only available with conduit connections option E.
R	Piece-wise linearization for gas Approval code J is only available with conduit connections option E.
X	ETO software option 1 Requires factory code X

Code	Software options 1 — only available with mounting code H (1)
B	CDM density meter connection - IIC ATEX & IECEx rating Not available with display code 2
C	FDM density meter connection - IIC ATEX & IECEx rating Not available with display code 2
D	FVM viscosity meter connection - IIC ATEX & IECEx rating Not available with display code 2
E	CDM density meter connection - CSA C1D1 & C1D2 and Zone 2 or 3 ATEX, IECEx ratings Not available with display code 5
F	FDM density meter connection - CSA C1D1 & C1D2 and Zone 2 or 3 ATEX, IECEx ratings Not available with display code 5
H	FVM viscosity meter connection - CSA C1D1 & C1D2 and Zone 2 or 3 ATEX, IECEx ratings Not available with display code 5

(1) All concentration measurement or petroleum measurement options are automatically programmed by the CDM / FDM.

Software 2

Code	Software options 2 for Model 2700 — available with all mounting codes
Z	No software options 2
W	Weights & measures custody transfer Only available with output codes A, B, C, 2 or 3; Not available with Software Options 1 codes C or D
X	ETO software option 2; requires factory code X

Code	Software options 2 for Model 2700 — available only with mounting codes R, I, B, E, C, or M and P
C	Smart Meter Verification Not available with Mounting Option I, B, C, or P; Smart Meter Verification is not available with all sensors.
D	Weights & measures custody transfer and Smart Meter Verification Not available with Mounting Option I, B, C, or P; Smart Meter Verification is not available with all sensors.
A	Regulatory Control Suite: Standard function blocks plus 1 PID block Available with output codes E and N only
F	Regulatory Control Suite: Standard function blocks plus 1 PID block & Smart Meter Verification Available with output codes E and N only; Available with sensor electronic interface codes 2 through 5 only; Not available with mounting option I, B, E, C, or P
S	Safety Certification of 4-20 mA output per IEC 61508 Available with Output codes A, B, C, and D only

Code	Software options 2 for Model 2700 — available only with mounting codes R, I, B, E, C, or M and P
V	Safety Certification per IEC 61508 with Smart Meter Verification Available with output codes E and N only; Available with sensor electronic interface codes 2 through 5 only; Not available with mounting option I, B, E, C, or P; Not available with approval options S or T with conduit connections L or M

Factory

Code	Factory options for Model 2700
Z	Standard product
X	ETO product

Add on Options

Code	Add on options for Model 2700 — Available only for output code 2, 3, or 4
PI	Model 775 integrally mounted at the factory, wiring completed in the field Not available with approvals J, T, or S; Add on option PI is not available with Output code 4 and approval code A. CSA requires installation with a poured conduit seal or stopping box between the transmitter and the 775 Thum.
NI	Model 775 not installed, installation and wiring completed in the field Not available with approvals J, T, or S

Code	Add on options for Model 2700 — for mounting code R, B, E, H, M, P, or C
PK	2-inch pipe mount U-bolt kit for electronics

Code	Add on options for Model 2700 — Country-specific approval (select one from the following if approval code G is selected)
R1	EAC Zone 2 - Hazardous Area Approval - Increased safety terminal compartment (Exe)
R2	EAC Zone 1 - Hazardous Area Approval - Flameproof terminal compartment
R3	EAC Zone 2 - Hazardous Area Approval - Energy limited device (ExnA) Sensor connections will be intrinsically safe without additional barrier
B1	INMETRO Zone 1 - Hazardous Area Approval - Increased safety terminal compartment N/C
B2	INMETRO Zone 1 - Hazardous Area Approval - Flameproof terminal compartment
B3	INMETRO Zone 2 - Hazardous Area Approval Sensor connections will be intrinsically safe without additional barrier

Emerson Automation Solutions

Worldwide Headquarters
7070 Winchester Circle
Boulder, Colorado USA 80301
T: +1 800-522-6277
T: +1 303-527-5200
F: +1 303-530-8459
Mexico: 52 55 5809 5300
Argentina: 54 11 4837 7000
Brazil: 55 15 3413 8147
Chile: 56 2 2928 4800

Emerson Automation Solutions

Central Europe: +41 41 7686 111
Eastern Europe: +41 41 7686 111
Dubai: +971 4 811 8100
Abu Dhabi: +971 2 697 2000
France: 0800 917 901
Germany: +49 (0) 2173 3348 0
Italy: 8008 77334
The Netherlands: +31 (0) 70 413 6666
Belgium: +32 2 716 77 11
Spain: +34 913 586 000
U.K.: 0870 240 1978
Russian/CIS: +7 495 981 9811

Emerson Automation Solutions

Australia: (61) 3 9721 0200
China: (86) 21 2892 9000
India: (91) 22 6662 0566
Japan: (81) 3 5769 6803
South Korea: (82) 31 8034 0000
Singapore: (65) 6 777 8211

©2018 Micro Motion, Inc. All rights reserved.

The Emerson logo is a trademark and service mark of Emerson Electric Co. Micro Motion, ELITE, ProLink, MVD and MVD Direct Connect marks are marks of one of the Emerson Automation Solutions family of companies. All other marks are property of their respective owners.