



Level



Pressure



Flow



Temperature



Liquid
Analysis



Registration



Systems
Components



Services



Solutions

Technical Information

iTEMP[®] TMT111, DIN rail

Universal temperature transmitter for resistance thermometers (RTD), thermocouples, resistance and voltage transmitters, PC programmable, for installation on DIN rail according to IEC 60715



Application

- PC programmable (PCP) DIN rail temperature transmitter for converting various input signals into a scalable 4 to 20 mA analog output signal
- Usable for resistance thermometer (RTD), thermocouple (TC), resistance transmitter (Ω), voltage transmitter (mV)
- Device configuration using PC with configuration kit and PC-Software ReadWin[®] 2000
- Installation on DIN rail according to IEC 60715, TH35

Your benefits

- 2-wire technology, 4 to 20 mA analog output
- Fault signal on sensor break or short circuit, presettable to NAMUR NE 43
- UL recognized component to UL 3111-1
- CSA General Purpose
- Meets the EMC requirements as per NAMUR NE21
- Ex-Certification:
 - ATEX Ex ia
 - CSA IS
 - FM IS
- Galvanic isolation 2 kV (input/output)
- Output simulation for quick and easy testing of the measurement loop

Function and system design

Measuring principle Electronic measurement and conversion of input signals in industrial temperature measurement.

Measuring system The iTEMP[®] TMT111, DIN rail temperature transmitter is a 2-wire transmitter with an analog output. It has a measurement input for resistance thermometers (RTD) and resistance transmitters in 2-, 3- or 4-wire connection, thermocouples and voltage transmitters. Setting up of the TMT111 is done using a configuration kit (see chapter “Accessories” on page 9 and the free of charge configuration software ReadWin[®] 2000.

Input

Measured variable Temperature (temperature linear), resistance and voltage.

Measuring range Depending upon the sensor connection and input signal. The transmitter evaluates a number of different measurement ranges.

Type of input	Designation	Measurement range limits	Minimum measurement range	
Resistance thermometer (RTD) as per IEC 60751 ($\alpha = 0.00385$)	Pt100	-200 to 850 °C (-328 to 1562 °F)	10 K	
	Pt500	-200 to 250 °C (-328 to 482 °F)	10 K	
	Pt1000	-200 to 250 °C (-328 to 482 °F)	10 K	
	as per DIN 43760 ($\alpha = 0.006180$)	Ni100 Ni500 Ni1000	-60 to 250 °C (-76 to 482 °F) -60 to 150 °C (-76 to 302 °F) -60 to 150 °C (-76 to 302 °F)	10 K 10 K 10 K
as per Edison Curve ($\alpha = 0.006720$)	Ni120	-70 to 270 °C (-94 to 518 °F)	10 K	
	<ul style="list-style-type: none"> ■ Connection type: 2-wire, 3-wire or 4-wire connection ■ For 2-wire circuit, compensation for wire resistance possible (0 to 20 Ω) ■ Sensor cable resistance max. 40 Ω per cable ■ Sensor current: ≤ 0.6 mA 			
Resistance transmitter	Resistance Ω	10 to 400 Ω 10 to 2000 Ω	10 Ω 100 Ω	
Thermocouples (TC) as per IEC 584 part 1	B (PtRh30-PtRh6)	0 to +1820 °C (32 to 3308 °F)	500 K	
	E (NiCr-CuNi)	-270 to +1000 °C (-454 to 1832 °F)	50 K	
	J (Fe-CuNi)	-210 to +1200 °C (-346 to 2192 °F)	50 K	
	K (NiCr-Ni)	-270 to +1372 °C (-454 to 2501 °F)	50 K	
	N (NiCrSi-NiSi)	-270 to +1300 °C (-454 to 2372 °F)	50 K	
	R (PtRh13-Pt)	-50 to +1768 °C (-58 to 3214 °F)	500 K	
	S (PtRh10-Pt)	-50 to +1768 °C (-58 to 3214 °F)	500 K	
	T (Cu-CuNi)	-270 to +400 °C (-454 to 752 °F)	50 K	
	as per ASTM E988	C (W5Re-W26Re) D (W3Re-W25Re)	0 to +2320 °C (32 to 4208 °F) 0 to +2495 °C (32 to 4523 °F)	500 K 500 K
	as per DIN 43710	L (Fe-CuNi) U (Cu-CuNi)	-200 to +900 °C (-328 to 1652 °F) -200 to +600 °C (-328 to 1112 °F)	50 K 50 K
	<ul style="list-style-type: none"> ■ Internal cold junction (Pt100) or external 0 °C to +80 °C (32 to 176 °F) ■ Cold junction accuracy: ± 1 K 			
Voltage transmitters (mV)	Millivolt transmitter (mV)	-10 to 100 mV	5 mV	

Output

Output signal	Analog 4 to 20 mA, 20 to 4 mA
Signal on alarm	<ul style="list-style-type: none"> ■ Underranging: Linear drop to 3.8 mA ■ OVERRANGING: Linear rise to 20.5 mA ■ Sensor breakage; Sensor short circuit¹: ≤ 3.6 mA or ≥ 21.0 mA (for configuration ≥ 21.0 mA, output ≥ 21.5 mA is guaranteed)
Load	Max. $(V_{\text{Power supply}} - 12 \text{ V}) / 0.022 \text{ A}$ (Current output)
Linearization / transmission behavior	Temperature linear, resistance linear, voltage linear
Filter	Digital filter 1 st degree: 0 to 8 s
Galvanic isolation	U = 2 kV AC (Input/output)
Min. current consumption	≤ 3.5 mA
Current limit	≤ 23 mA
Switch-on delay	4 s (during power up $I_a \approx 3.8 \text{ mA}$)

Power supply

Electrical connection

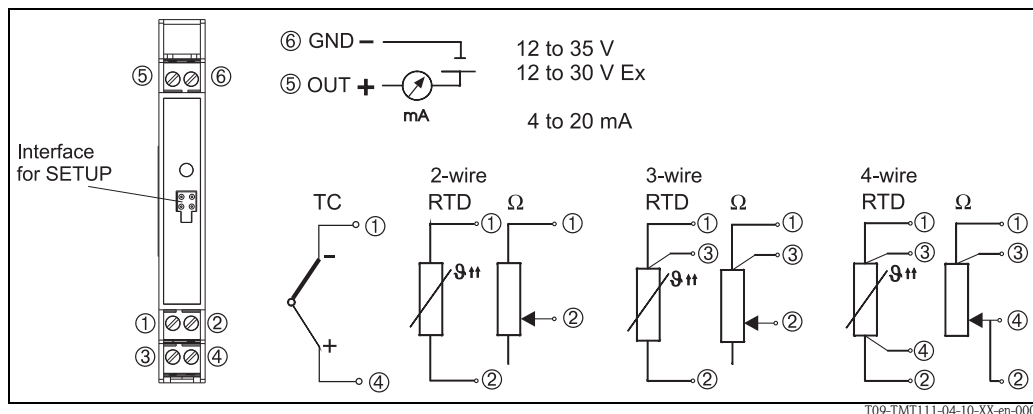

T09-TMT111-04-10-XX-en-000

Connection terminal	Sensor-connection cable	
	Option 1	Option 2
	① Red, ② White	① White, ② Red
	③ Red, ④ White	③ White, ④ Red

Temperature transmitter terminal connections

Supply voltage	$U_b = 12 \text{ to } 35 \text{ V}$, polarity protected
	<ol style="list-style-type: none"> 1. Not for thermocouple

Residual ripple Allowable ripple $U_{ss} \leq 3 \text{ V}$ at $U_b \geq 15 \text{ V}$, $f_{\text{max.}} = 1 \text{ kHz}$

Performance characteristics

Response time 1 s

Reference operating conditions

- Calibration temperature: $+25 \text{ °C} \pm 5 \text{ K}$ ($77 \text{ °F} \pm 9 \text{ °F}$)
- Supply voltage: 24 V DC
- 4-wire circuit for resistance adjustment

Maximum measured error The accuracy data are typical values and correspond to a standard deviation of $\pm 3\sigma$ (normal distribution), i.e. 99.8% of all the measured values achieve the given values or better values.

	Type	Measurement accuracy
Resistance thermometer RTD	Pt100, Ni100	0.2 K or 0.08%
	Pt500, Ni500	0.5 K or 0.20%
	Pt1000, Ni1000	0.3 K or 0.12%
Thermocouple TC	K, J, T, E, L, U	typ. 0.5 K or 0.08%
	N, C, D	typ. 1.0 K or 0.08%
	S, B, R	typ. 2.0 K or 0.08%

	Measurement range	Measurement accuracy
Resistance transmitter (Ω)	10 to 400 Ω	$\pm 0.1 \text{ } \Omega$ or 0.08%
	10 to 2000 Ω	$\pm 1.5 \text{ } \Omega$ or 0.12%
Voltage transmitter (mV)	-10 to 100 mV	$\pm 20 \text{ } \mu\text{V}$ or 0.08%

Influence of power supply $\leq \pm 0.01\%/V$ deviation from 24 V¹

Influence of ambient temperature (temperature drift) Total temperature drift = input temperature drift + output temperature drift

Impact on accuracy when ambient temperature changes by 1 K (1.8 °F):	
Input 10 to 400 Ω	Typ. 0.001% of the measured value, min. 1 m Ω
Input 10 to 2000 Ω	Typ. 0.001% of the measured value, min. 10 m Ω
Input -10 to 100 mV	Typ. 0.001% of the measured value, min. 0.2 μV @
@f _{put} 4 to 20 mA	Typ. 0.0015% of the span

Typical sensitivity of resistance thermometers	
Pt: $0.00385 * R_{\text{nom}}/K$	Ni: $0.00617 * R_{\text{nom}}/K$
Example Pt100: $0.00385 * 100 \text{ } \Omega/K = 0.385 \text{ } \Omega/K$	

Typical sensitivity of thermocouples:					
B: 9 $\mu\text{V}/K$ at 1000 °C (1832 °F)	C: 18 $\mu\text{V}/K$ at 1000 °C (1832 °F)	D: 20 $\mu\text{V}/K$ at 1000 °C (1832 °F)	E: 81 $\mu\text{V}/K$ at 500 °C (932 °F)	J: 56 $\mu\text{V}/K$ at 500 °C (932 °F)	K: 43 $\mu\text{V}/K$ at 500 °C (932 °F)
L: 60 $\mu\text{V}/K$ at 500 °C (932 °F)	N: 38 $\mu\text{V}/K$ at 500 °C (932 °F)	R: 13 $\mu\text{V}/K$ at 1000 °C (1832 °F)	S: 11 $\mu\text{V}/K$ at 1000 °C (1832 °F)	T: 46 $\mu\text{V}/K$ at 100 °C (212 °F)	U: 70 $\mu\text{V}/K$ at 500 °C (932 °F)

Example of calculating the measured error with ambient temperature drift:

Input temperature drift $\Delta \vartheta = 10 \text{ K}$ (18 °F), Pt100, measuring range 0 to 100 °C (32 to 212 °F). Maximum process temperature: 100 °C (212 °F)

Measured resistance value: 138.5 Ω (IEC 60751) at maximum process temperature

Typical temperature drift in Ω : (0.001% of 138.5 Ω) * 10 = 0.01385 Ω

Conversion to Kelvin: 0.01385 Ω / 0.385 Ω/K = 0.04 K (0.054 °F)

Long-term stability	$\leq 0.1\text{K}/\text{year}$ or $\leq 0.05\%/ \text{year}^1$ ²
Influence of load	$\leq \pm 0.02\%/100 \Omega^1$
Influence of cold junction	Pt100 DIN IEC 60751 Cl. B (internal cold junction with thermocouples TC)

1) according to reference conditions

2) % is related to the adjusted measurement range (the value to be applied is the greater one)

Installation conditions

Installation instructions

■ Mounting location:

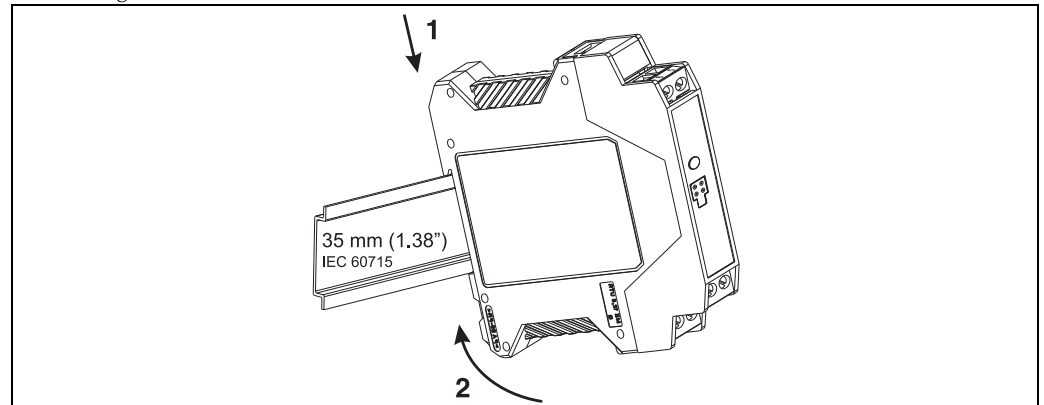

Installation on DIN rail according to IEC 60715, TH35 - follow sequence 1 and 2

T09-TMT111-17-10-06-zx-000

- #### ■ Orientation:
- No restrictions

Environmental conditions

Ambient temperature	-40 to +85 °C (-40 to +185 °F) - for Ex-areas see Ex-certification
Storage temperature	-40 to +100 °C (-40 to 212 °F)
Climate class	According to IEC 60654-1, Class C
Degree of protection	IP20 (NEMA Type 1 Encl.)
Electromagnetic compatibility (EMC)	Interference immunity and interference emission according to IEC 61326 and NAMUR NE 21
Humidity	<ul style="list-style-type: none"> ■ Condensation as per IEC 60 068-2-33 permitted ■ Max. rel. humidity: 95% as per IEC 60068-2-30

Mechanical construction

Design, dimensions

Installation on DIN rail according to IEC 60715, TH35

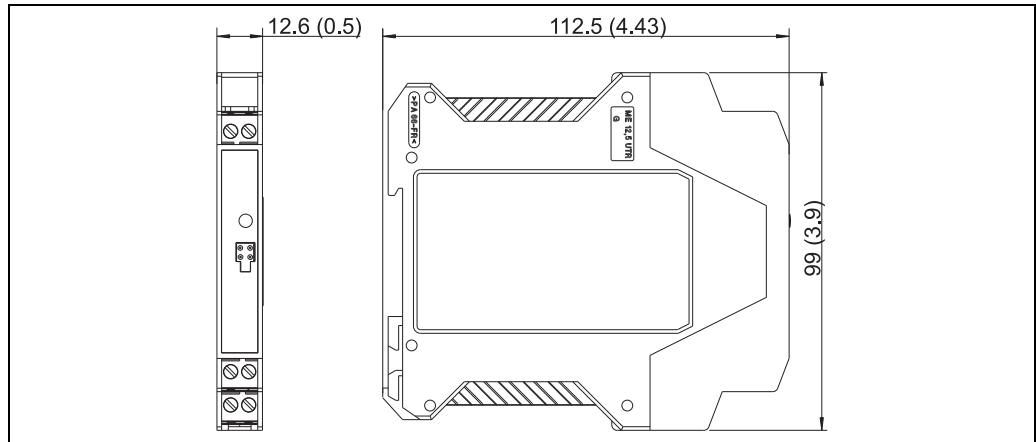

Dimensions in mm (in)

T09-TMT111-06-10-XX-XX-000

Weight	Approx. 90 g (3.17 oz)
Material	Housing: Plastic PC/ABS, UL 94V0
Terminals	Keyed plug-in screw terminals, core size max. 2.5 mm ² (16 AWG) solid, or strands with ferrules

Human interface

Display elements A yellow illuminated LED signalizes: Device is operational.

Operating elements No operating elements are available on the temperature transmitter. The temperature transmitter will be configured by remote operation with the PC software ReadWin® 2000. Available configuration kits see chapter 'accessories' on page 9.

Operation via PC

Menu	Configurable parameters
Standard settings	<ul style="list-style-type: none"> ■ Sensor type ■ Connection (2-, 3- or 4-wire connection) ■ Units °C, °F ■ Measurements range limits (depends on selected sensor type)
Expanded settings	<ul style="list-style-type: none"> ■ Cold junction compensation (internal/external on TC connection) ■ Temperature external (on TC with cold junction compensation external) ■ Compensation resistance (0 to 20 Ω) on RTD 2-wire connection ■ Fault condition reaction (≤ 3.6 mA or ≥ 21.0 mA), for configuration ≥ 21.0 mA, output ≥ 21.5 mA is guaranteed ■ Analog output: 4 to 20 mA (standard) or 20 to 4 mA (inverse) ■ Filter, optional from 0 to 8 s ■ Zero point, offset (-9.9 to +9.9 K / -18 to +18 °F) ■ TAG (Measurement point description)
Service functions	<ul style="list-style-type: none"> ■ Simulation analog output: on/off ■ Password assignment

Certificates and approvals

CE approval

The measurement system fulfils the requirements demanded by the EU regulations. Endress+Hauser acknowledges successful unit testing by adding the CE mark.

Hazardous area approvals

ATEX approval

TMT111		ATEX II 2(1)G	EEx ia IIC	T6/T5/T4
Power supply (Terminals 5 and 6)		$U_i \leq 30$ V DC $I_i \leq 100$ mA $P_i \leq 750$ mW $C_i =$ negligibly small $L_i =$ negligibly small		
Sensor circuit (Terminals 1 to 4)		$U_0 \leq 4.4$ V DC $I_0 \leq 9.6$ mA $P_0 \leq 10.6$ mW		
Max. connection data	EEx ia IIC EEx ia IIB	$L_0 = 100$ mH $L_0 = 100$ mH		$C_0 = 2.4$ μ F $C_0 = 12$ μ F
Temperature range	T6 T5 T4	$T_a = -40$ °C ... +50 °C $T_a = -40$ °C ... +65 °C $T_a = -40$ °C ... +85 °C		

Application:

- Equipment Category: Explosive gas-air mixtures (G)
- Category 1 Zone 1 or 2, Apparatus with external circuits for connection to equipment in category 1



Note!

For Zone 0: This apparatus may be installed in Zones 1, 2 and the sensor circuit can be fed into Zone 0.

FM approval

TMT111		IS / Class I / Division 1 / Groups ABCD / T4/T5/T6 Class I / Zone 0 / AEx ia IIC / T4/T5/T6 NI / Class I / Division 2 / Groups ABCD / T4/T5/T6		
Supply circuit (Terminals 5 and 6)		$U_i \leq 30$ V DC $I_i \leq 100$ mA $P_i \leq 750$ mW $C_i =$ negligible small $L_i =$ negligible small		
Sensor circuit (Terminals 1 to 4)		$U_0 \leq 2.5$ V DC $I_0 \leq 2.2$ mA $P_0 \leq 1.4$ mW		
Max. connecting values	Group A, B Group C Group D	IIC IIB IIA	$L_a = L_0 = 1000$ mH $L_a = L_0 = 1000$ mH $L_a = L_0 = 1000$ mH	$C_a = C_0 = 100$ μ F $C_a = C_0 = 1000$ μ F $C_a = C_0 = 1000$ μ F
Temperature range	T6 T5 T4		$T_a = -40$ °C ... +50 °C $T_a = -40$ °C ... +65 °C $T_a = -40$ °C ... +85 °C	

Labeling:

- IS / Class I / Division 1 / Groups ABCD / T4/T5/T6
- Class I / Zone 0 / AEx ia IIC / T4/T5/T6
- NI / Class I / Division 2 / Groups ABCD / T4/T5/T6

Application:

- Intrinsic Safety
- Non-Incendive

CSA (Canadian Standard Association)

TMT111		IS / Class I / Division 1 / Groups ABCD / T4/T5/T6 Ex ia IIC / T4/T5/T6 NI / Class I / Division 2 / Groups ABCD / T4/T5/T6	
Supply circuit (Terminals 5+ and 6-)		$U_i \leq 30 \text{ V DC}$ $I_i \leq 100 \text{ mA}$ $P_i \leq 750 \text{ mW}$ $C_i = \text{negligible small}$ $L_i = \text{negligible small}$	
Sensor circuit (Terminals 1 to 4)		$U_0 \leq 4.4 \text{ V DC}$ $I_0 \leq 9.6 \text{ mA}$ $P_0 \leq 10.2 \text{ mW}$	
Max. connecting values	Group A, B Group C Group D	IIC IIB IIA	$L_a = L_0 = 100 \text{ mH}$ $C_a = C_0 = 100 \mu\text{F}$ $L_a = L_0 = 100 \text{ mH}$ $C_a = C_0 = 1000 \mu\text{F}$ $L_a = L_0 = 100 \text{ mH}$ $C_a = C_0 = 1000 \mu\text{F}$
Temperature range	T6 T5 T4	$T_a = -40 \text{ }^\circ\text{C} \dots +50 \text{ }^\circ\text{C}$ $T_a = -40 \text{ }^\circ\text{C} \dots +65 \text{ }^\circ\text{C}$ $T_a = -40 \text{ }^\circ\text{C} \dots +85 \text{ }^\circ\text{C}$	

Labeling:

- Class I / Div. 1 / Groups ABCD / T4/T5/T6
- Class I / Div. 2 / Groups ABCD / T4/T5/T6

Application:

- Intrinsically safe
- Non-Incendive

For further details on the available Ex versions (ATEX, CSA, FM, etc.), please contact your nearest Endress+Hauser sales organization. All relevant data for hazardous areas can be found in separate Ex documentation. If required, please request copies from your Endress+Hauser sales organization.

UL

Recognized component to UL 3111-1

CSA GP

CSA General Purpose according to C22.2 No. 1010.1-92

Other standards and guidelines

- IEC 60529: Degrees of protection by housing (IP code)
- IEC 61010: Safety requirements for electrical measurement, control and laboratory instrumentation
- IEC 61326: Electromagnetic compatibility (EMC requirements)
- NAMUR: International user association of automation technology in process industries (www.namur.de).

Ordering information

Detailed ordering information is available from the following sources:

- In the Product Configurator on the Endress+Hauser website:
www.endress.com → Select country → Instruments → Select device → Product page function:
Configure this product
- From your Endress+Hauser Sales Center:
www.endress.com/worldwide

Product Configurator - the tool for individual product configuration:

- Up-to-the-minute configuration data
- Depending on the device: Direct input of measuring point-specific information such as measuring range or operating language
- Automatic verification of exclusion criteria
- Automatic creation of the order code and its breakdown in PDF or Excel output format
- Ability to order directly in the Endress+Hauser Online Shop

Accessories

Configuration kits for PC programmable transmitters

- FXA291 Commubox: PC-interface cable with 4-pin USB-plug;
Order-Code: 51516983
- TMT121A-VK: Setup-program ReadWin[®] 2000 and PC-interface cable (TTL/RS232C);
Order-Code: TMT121A-VK
- TXU10-AA: Setup-program ReadWin[®] 2000 and PC-interface cable with 4-pin USB-plug;
Order-Code: TXU10-AA

The operating software ReadWin[®] 2000 can be downloaded free of charge from the Internet from the following address: www.endress.com/readwin

Documentation

- Operating Instructions "iTEMP[®] TMT111 DIN rail" (BA159R/09/c4)
- Ex supplementary documentation: ATEX II 2(1) G EEx ia IIC (XA021R/09/a3)

Instruments International

Endress+Hauser
Instruments International AG
Kaegenstrasse 2
4153 Reinach
Switzerland

Tel.+41 61 715 81 00
Fax+41 61 715 25 00
www.endress.com
info@ii.endress.com

Endress + Hauser 
People for Process Automation