

# Technical Information

## Proline Promass 80F, 83F

Coriolis flowmeter



The flowmeter with premium accuracy and robustness with a compact or remote transmitter

### Application

- Measuring principle operates independently of physical fluid properties such as viscosity or density
- Highest measurement performance for liquids and gases under varying, demanding process conditions

### Device properties

- Mass flow: measured error  $\pm 0.05\%$  (PremiumCal)
- Rated secondary containment up to 40 bar (580 psi)
- Nominal diameter: DN 8 to 250 ( $\frac{3}{8}$  to 10")
- 4-line backlit display with touch control (Promass 83)
- Device in compact or remote version
- HART, PROFIBUS PA/DP, Modbus RS485, FF, EtherNet/IP (Promass 83)

### Your benefits

- Highest process safety – immune to fluctuating and harsh environments
- Fewer process measuring points – multivariable measurement (flow, density, temperature)
- Space-saving installation – no in/outlet run needs
- Safe operation – display provides easy readable process information
- Quality – software for filling & dosing, density & concentration, advanced diagnostics (Promass 83)
- Automatic recovery of data for servicing
- Fully industry compliant – IEC/EN/NAMUR

## Table of contents

<b>Function and system design</b> .....	<b>3</b>	Medium density .....	21
Measuring principle .....	3	Medium pressure range (nominal pressure) .....	21
Measuring system .....	4	Pressure-temperature ratings .....	23
<b>Input</b> .....	<b>5</b>	Rupture disk .....	28
Measured variable .....	5	Limiting flow .....	28
Measuring range .....	5	Pressure loss .....	28
Operable flow range .....	6	System pressure .....	28
Input signal .....	6	Thermal insulation .....	29
<b>Output</b> .....	<b>6</b>	Heating .....	29
Output signal .....	6	<b>Mechanical construction</b> .....	<b>30</b>
Signal on alarm .....	8	Design, dimensions .....	30
Load .....	8	Weight .....	65
Low flow cutoff .....	8	Material .....	65
Galvanic isolation .....	8	Process connections .....	66
Switching output .....	8	<b>Operability</b> .....	<b>66</b>
<b>Power supply</b> .....	<b>9</b>	Local operation .....	66
Terminal assignment .....	9	Language group .....	67
Supply voltage .....	10	Remote operation .....	67
Power consumption .....	10	<b>Certificates and approvals</b> .....	<b>67</b>
Power supply failure .....	10	CE mark .....	67
Electrical connection .....	11	C-Tick symbol .....	67
Electrical connection remote version .....	12	Ex approval .....	67
Potential equalization .....	12	Sanitary compatibility .....	67
Cable entries .....	12	Functional safety .....	67
Remote version cable specification .....	12	HART certification .....	68
<b>Performance characteristics</b> .....	<b>12</b>	FOUNDATION Fieldbus certification .....	68
Reference operating conditions .....	12	PROFIBUS DP/PA certification .....	68
Maximum measured error .....	13	Modbus certification .....	68
Repeatability .....	15	Pressure measuring device approval .....	68
Response time .....	15	Other standards and guidelines .....	68
Influence of medium temperature .....	15	<b>Ordering Information</b> .....	<b>70</b>
Influence of medium pressure .....	15	<b>Accessories</b> .....	<b>70</b>
Design fundamentals .....	16	Device-specific accessories .....	70
<b>Installation</b> .....	<b>17</b>	Communication-specific accessories .....	71
Mounting location .....	17	Service-specific accessories .....	71
Orientation .....	18	System components .....	71
Installation instructions .....	19	<b>Documentation</b> .....	<b>72</b>
Inlet and outlet runs .....	19	<b>Registered trademarks</b> .....	<b>72</b>
Length of connecting cable .....	19		
Special installation instructions .....	19		
<b>Environment</b> .....	<b>21</b>		
Ambient temperature range .....	21		
Storage temperature .....	21		
Degree of protection .....	21		
Shock resistance .....	21		
Vibration resistance .....	21		
Electromagnetic compatibility (EMC) .....	21		
<b>Process</b> .....	<b>21</b>		
Medium temperature range .....	21		

## Function and system design

### Measuring principle

The measuring principle is based on the controlled generation of Coriolis forces. These forces are always present when both translational and rotational movements are superimposed.

$$F_C = 2 \cdot \Delta m (v \cdot \omega)$$

$F_C$  = Coriolis force

$\Delta m$  = moving mass

$\omega$  = rotational velocity

$v$  = velocity of the moving mass in a rotating or oscillating system

The amplitude of the Coriolis force depends on the moving mass  $\Delta m$ , its velocity  $v$  in the system, and thus on the mass flow. Instead of a constant angular velocity  $\omega$ , the Promass sensor uses oscillation.

The measuring tubes through which the measured material flows are brought into oscillation. The Coriolis forces produced at the measuring tubes cause a phase shift in the tube oscillations (see illustration):

- At zero flow, in other words when the fluid is at a standstill, the two tubes oscillate in phase (1).
- Mass flow causes deceleration of the oscillation at the inlet of the tubes (2) and acceleration at the outlet (3).

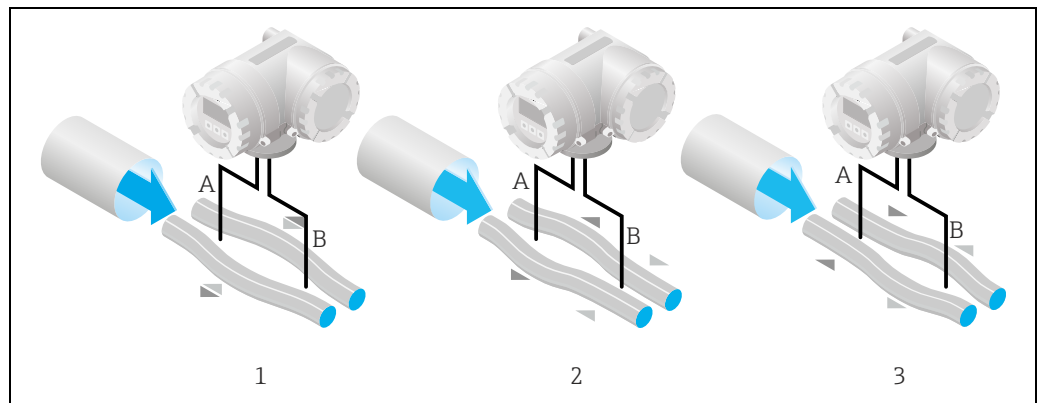

The phase difference (A-B) increases with increasing mass flow. Electrodynamic sensors register the tube oscillations at the inlet and outlet.

System balance is ensured by the antiphase oscillation of the two measuring tubes. The measuring principle operates independently of temperature, pressure, viscosity, conductivity and flow profile.

### Density measurement

The measuring tubes are continuously excited at their resonance frequency. A change in the mass and thus the density of the oscillating system (comprising measuring tubes and fluid) results in a corresponding, automatic adjustment in the oscillation frequency. Resonance frequency is thus a function of fluid density. The microprocessor utilizes this relationship to obtain a density signal.

### Temperature measurement

The temperature of the measuring tubes is determined in order to calculate the compensation factor due to temperature effects. This signal corresponds to the process temperature and is also available as an output.

**Measuring system**

The measuring system consists of a transmitter and a sensor. Two versions are available:

- Compact version: transmitter and sensor form a mechanical unit
- Remote version: transmitter and sensor are mounted physically separate from one another

**Transmitter**

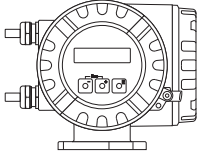
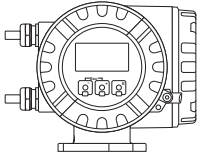
<p><b>Promass 80</b></p>  <p style="text-align: right; font-size: small;">a0003671</p>	<ul style="list-style-type: none"> <li>■ Two-line liquid-crystal display</li> <li>■ Operation with push buttons</li> </ul>
<p><b>Promass 83</b></p>  <p style="text-align: right; font-size: small;">a0003672</p>	<ul style="list-style-type: none"> <li>■ Four-line liquid-crystal display</li> <li>■ Operation with "Touch control"</li> <li>■ Application-specific Quick Setup</li> <li>■ Mass flow, volume flow, density and temperature measurement as well as calculated variables (e.g. fluid concentrations)</li> </ul>

**Sensor**

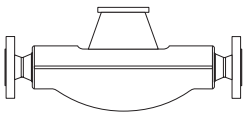
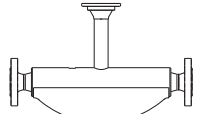
<p><b>F (Standard version)</b></p>  <p style="text-align: right; font-size: small;">a0003673</p>	<ul style="list-style-type: none"> <li>■ Universal sensor for fluid temperatures up to +200 °C (+392 °F).</li> <li>■ Nominal diameters DN 8 to 250 (3/8" to 10").</li> <li>■ Material: Stainless Steel EN 1.4539/ASTM 904L, EN 1.4404/ASTM 316L, Alloy C22 DIN 2.4602</li> <li>■ Material: <ul style="list-style-type: none"> <li>- Sensor: Stainless Steel: 1.4301/1.4307 (304L), optional 1.4404 (316/316L)</li> <li>- Measuring tube: Stainless Steel: 1.4539 (904L), 1.4404 (316/316L); Alloy C22, 2.4602 (UNS N06022)</li> <li>- Process connections: Stainless Steel: 1.4301 (F304), 1.4404 (316/316L); Alloy C22, 2.4602 (UNS N06022)</li> </ul> </li> </ul>
<p><b>F (High-temperature version)</b></p>  <p style="text-align: right; font-size: small;">a0003675</p>	<ul style="list-style-type: none"> <li>■ Universal high-temperature sensor for fluid temperatures up to +350 °C (+662 °F).</li> <li>■ Nominal diameters DN 25, 50, 80 (1", 2", 3")</li> <li>■ Material: <ul style="list-style-type: none"> <li>- Process connections: Rostfreier Stahl 1.4404 (316/316L); Alloy C22, 2.4602 (UNS N06022)</li> </ul> </li> </ul>

# Input

**Measured variable**

- Mass flow (proportional to the phase difference between two sensors mounted on the measuring tube to register a phase shift in the oscillation)
- Fluid density (proportional to resonance frequency of the measuring tube)
- Fluid temperature (measured with temperature sensors)

**Measuring range**

**Measuring ranges for liquids**

DN		Range for full scale values (liquids) $\dot{m}_{\min(F)}$ to $\dot{m}_{\max(F)}$	
[mm]	[in]	[kg/h]	[lb/min]
8	3/8	0 to 2 000	0 to 73.50
15	1/2	0 to 6 500	0 to 238.9
25	1	0 to 18 000	0 to 661.5
40	1 1/2	0 to 45 000	0 to 1 654
50	2	0 to 70 000	0 to 2 573
80	3	0 to 180 000	0 to 6 615
100	4	0 to 350 000	0 to 12 860
150	6	0 to 800 000	0 to 29 400
250	10	0 to 2 200 000	0 to 80 850

**Measuring ranges for gases**

The full scale values depend on the density of the gas. Use the formula below to calculate the full scale values:

$$\dot{m}_{\max(G)} = \dot{m}_{\max(F)} \cdot \rho_{(G)} \div x \text{ [kg/m}^3 \text{ (lb/ft}^3\text{)]}$$

$$\dot{m}_{\max(G)} = \text{max. full scale value for gas [kg/h (lb/min)]}$$

$$\dot{m}_{\max(F)} = \text{max. full scale value for liquid [kg/h (lb/min)]}$$

$$\rho_{(G)} = \text{gas density in [kg/m}^3 \text{ (lb/ft}^3\text{)] under process conditions}$$

DN		X	DN		X
[mm]	[in]		[mm]	[in]	
8	3/8	60	80	3	110
15	1/2	80	100	4	130
25	1	90	150	6	200
40	1 1/2	90	250	10	200
50	2	90			

Here,  $\dot{m}_{\max(G)}$  can never be greater than  $\dot{m}_{\max(F)}$

Calculation example for gas:

- Sensor type: Promass F, DN 50
- Gas: air with a density of 60.3 kg/m<sup>3</sup> (at 20 °C and 50 bar)
- Measuring range (liquid): 70 000 kg/h
- x = 90 (for Promass F DN 50)

Max. possible full scale value:

$$\dot{m}_{\max(G)} = \dot{m}_{\max(F)} \cdot \rho_{(G)} \div x \text{ [kg/m}^3\text{]} = 70\,000 \text{ kg/h} \cdot 60.3 \text{ kg/m}^3 \div 90 \text{ kg/m}^3 = 46\,900 \text{ kg/h}$$

Recommended measuring ranges:

See information in the "Limiting flow" Section → 28

<b>Operable flow range</b>	Greater than 1000 :1. Flow rates above the preset full scale value do not overload the amplifier, i.e. the totalizer values are registered correctly.
<b>Input signal</b>	<p><b>Status input (auxiliary input)</b></p> <p>U = 3 to 30 V DC, <math>R_i = 5 \text{ k}\Omega</math>, galvanically isolated. Configurable for: totalizer reset, positive zero return, error message reset, zero point adjustment start, batching start/stop (optional), totalizer reset for batching (optional).</p> <p><b>Status input (auxiliary input) with PROFIBUS DP</b></p> <p>U = 3 to 30 V DC, <math>R_i = 3 \text{ k}\Omega</math>, galvanically isolated. Switch level: <math>\pm 3</math> to <math>\pm 30</math> V DC, independent of polarity. Configurable for: positive zero return, error message reset, zero point adjustment start, batching start/stop (optional), totalizer reset for batching (optional).</p> <p><b>Status input (auxiliary input) with Modbus RS485</b></p> <p>U = 3 to 30 V DC, <math>R_i = 3 \text{ k}\Omega</math>, galvanically isolated. Switch level: <math>\pm 3</math> to <math>\pm 30</math> V DC, independent of polarity. Configurable for: totalizer reset, positive zero return, error message reset, zero point adjustment start.</p> <p><b>Current input (only Promass 83)</b></p> <p>Active/passive selectable, galvanically isolated, resolution: <math>2 \mu\text{A}</math></p> <ul style="list-style-type: none"> <li>■ Active: 4 to 20 mA, <math>R_L &lt; 700 \Omega</math>, <math>U_{\text{out}} = 24 \text{ V DC}</math>, short-circuit proof</li> <li>■ Passive: 0/4 to 20 mA, <math>R_i = 150 \Omega</math>, <math>U_{\text{max}} = 30 \text{ V DC}</math></li> </ul>

## Output

<b>Output signal</b>	<p><b>Promass 80</b></p> <p><i>Current output</i></p> <p>Active/passive selectable, galvanically isolated, time constant selectable (0.05 to 100 s), full scale value selectable, temperature coefficient: typically 0.005% o.r./°C, resolution: <math>0.5 \mu\text{A}</math></p> <ul style="list-style-type: none"> <li>■ Active: 0/4 to 20 mA, <math>R_L &lt; 700 \Omega</math> (for HART: <math>R_L \geq 250 \Omega</math>)</li> <li>■ Passive: 4 to 20 mA; supply voltage <math>U_s</math> 18 to 30 V DC; <math>R_i \geq 150 \Omega</math></li> </ul> <p><i>Pulse/frequency output</i></p> <p>Passive, open collector, 30 V DC, 250 mA, galvanically isolated.</p> <ul style="list-style-type: none"> <li>■ Frequency output: full scale frequency 2 to 1000 Hz (<math>f_{\text{max}} = 1250 \text{ Hz}</math>), on/off ratio 1:1, pulse width max. 2 s</li> <li>■ Pulse output: pulse value and pulse polarity selectable, pulse width configurable (0.5 to 2000 ms)</li> </ul> <p><i>PROFIBUS PA interface</i></p> <ul style="list-style-type: none"> <li>■ PROFIBUS PA in accordance with EN 50170 Volume 2, IEC 61158-2 (MBP), galvanically isolated</li> <li>■ Profile Version 3.0</li> <li>■ Current consumption: 11 mA</li> <li>■ Permitted supply voltage: 9 to 32 V</li> <li>■ Bus connection with integrated reverse polarity protection</li> <li>■ Error current FDE (Fault Disconnection Electronic) = 0 mA</li> <li>■ Data transmission rate: 31.25 kBit/s</li> <li>■ Signal encoding: Manchester II</li> <li>■ Function blocks: 4 × Analog Input, 2 × Totalizer</li> <li>■ Output data: Mass flow, Volume flow, Density, Temperature, Totalizer</li> <li>■ Input data: Positive zero return (ON/OFF), Zero point adjustment, Measuring mode, Totalizer control</li> <li>■ Bus address can be configured via miniature switches or via the local display (optional)</li> </ul>
----------------------	---

**Promass 83***Current output*

Active/passive selectable, galvanically isolated, time constant selectable (0.05 to 100 s), full scale value selectable, temperature coefficient: typically 0.005% o.r./°C, resolution: 0.5  $\mu$ A

- Active: 0/4 to 20 mA,  $R_L < 700 \Omega$  (for HART:  $R_L \geq 250 \Omega$ )
- Passive: 4 to 20 mA; supply voltage  $U_S$  18 to 30 V DC;  $R_i \geq 150 \Omega$

*Pulse/frequency output*

active/passive selectable, galvanically isolated

- Active: 24 V DC, 25 mA (max. 250 mA during 20 ms),  $R_L > 100 \Omega$
- Passive: open collector, 30 V DC, 250 mA
- Frequency output:
  - full scale frequency 2 to 10000 Hz ( $f_{max} = 12500$  Hz), on/off ratio 1:1, pulse width max. 2 s
- Pulse output:
  - pulse value and pulse polarity selectable, pulse width configurable (0.05 to 2000 ms)

*HART protocol*

Order code "Power Supply; Display", option A, B, C, D, E, F, G, H, X, 7, 8 (HART 5)

- Valid until software version: 3.01.XX

Order code "Power Supply; Display", option P, Q, R, S, T, U, 4, 5 (HART 7)

- Valid as of software version: 3.07.XX

*PROFIBUS DP interface*

- PROFIBUS DP in accordance with EN 50170 Volume 2
- Profile Version 3.0
- Data transmission rate: 9.6 kBaud to 12 MBaud
- Automatic data transmission rate recognition
- Signal encoding: NRZ Code
- Function blocks: 6  $\times$  Analog Input, 3  $\times$  Totalizer
- Output data: Mass flow, Volume flow, Corrected volume flow, Density, Reference density, Temperature, Totalizers 1 to 3
- Input data: Positive zero return (ON/OFF), Zero point adjustment, Measuring mode, Totalizer control
- Bus address can be configured via miniature switches or via the local display (optional)
- Available output combination  $\rightarrow$   9

*PROFIBUS PA interface*

- PROFIBUS PA in accordance with EN 50170 Volume 2, IEC 61158-2 (MBP), galvanically isolated
- Data transmission rate:
  - 31.25 kBit/s
- Current consumption: 11 mA
- Permitted supply voltage: 9 to 32 V
- Bus connection with
  - integrated reverse polarity protection
- Error current FDE (Fault Disconnection Electronic): 0 mA
- Signal encoding: Manchester II
- Function blocks: 6  $\times$  Analog Input, 3  $\times$  Totalizer
- Output data: Mass flow, Volume flow, Corrected volume flow, Density, Reference density, Temperature, Totalizers 1 to 3
- Input data: Positive zero return (ON/OFF), Zero point adjustment, Measuring mode, Totalizer control
- Bus address can be configured via miniature switches or via the local display (optional)
- Available output combination  $\rightarrow$   9

*Modbus interface*

- Modbus device type: slave
- Address range: 1 to 247
- Supported function codes: 03, 04, 06, 08, 16, 23
- Broadcast: supported with the function codes 06, 16, 23
- Physical interface: RS485 in accordance with EIA/TIA-485 standard

- Supported baud rate: 1200, 2400, 4800, 9600, 19200, 38400, 57600, 115200 Baud
- Transmission mode: RTU or ASCII
- Response times:
  - Direct data access = typically 25 to 50 ms
  - Auto-scan buffer (data range) = typically 3 to 5 ms
- Possible output combinations → 9

#### *FOUNDATION Fieldbus interface*

- FOUNDATION Fieldbus H1, IEC 61158-2, galvanically isolated
- Data transmission rate: 31.25 kBit/s
- Current consumption: 12 mA
- Permitted supply voltage: 9 to 32 V
- Error current FDE (Fault Disconnection Electronic): 0 mA
- Bus connection with integrated reverse polarity protection
- Signal encoding: Manchester II
- ITK Version 5.01
- Function blocks:
  - 8 × Analog Input (Execution time: each 18 ms)
  - 1 × Digital Output (18 ms)
  - 1 × PID (25 ms)
  - 1 × Arithmetic (20 ms)
  - 1 × Input Selector (20 ms)
  - 1 × Signal Characterizer (20 ms)
  - 1 × Integrator (18 ms)
- Number of VCRs: 38
- Number of link objects in VFD: 40
- Output data: Mass flow, Volume flow, Corrected volume flow, Density, Reference density, Temperature, Totalizers 1 to 3
- Input data: Positive zero return (ON/OFF), Zero point adjustment, Measuring mode, Reset totalizer
- Link Master (LM) function is supported

---

#### Signal on alarm

#### Current output

Failsafe mode selectable (e.g. in accordance with NAMUR Recommendation NE 43)

#### Pulse/frequency output

Failsafe mode selectable

#### Status output (Promass 80)

Nonconductive in the event of a fault or if the power supply fails

#### Relay output (Promass 83)

Dead in the event of a fault or if the power supply fails

---

#### Load

see "Output signal"

---

#### Low flow cutoff

Switch points for low flow are selectable.

---

#### Galvanic isolation

All circuits for inputs, outputs, and power supply are galvanically isolated from each other.

---

#### Switching output

#### Status output (Promass 80)

- Open collector
- max. 30 V DC / 250 mA
- galvanically isolated
- Configurable for: error messages, Empty Pipe Detection (EPD), flow direction, limit values

#### Relay output (Promass 83)

- max. 30 V / 0.5 A AC; 60 V / 0.1 A DC
- galvanically isolated
- Normally closed (NC or break) or normally open (NO or make) contacts available (factory setting: relay 1 = NO, relay 2 = NC)



## Power supply

### Terminal assignment

#### Promass 80

Order characteristic for "inputs/outputs"	Terminal No. (inputs/outputs)			
	20 (+) / 21 (-)	22 (+) / 23 (-)	24 (+) / 25 (-)	26 (+) / 27 (-)
A	-	-	Frequency output	Current output, HART
D	Status input	Status output	Frequency output	Current output, HART
H	-	-	-	PROFIBUS PA
S	-	-	Frequency output Ex i, passive	Current output Ex i Active, HART
T	-	-	Frequency output Ex i, passive	Current output Ex i Passive, HART
8	Status input	Frequency output	Current output 2	Current output 1, HART

#### Promass 83

The inputs and outputs on the communication board can be either permanently assigned (fixed) or variable (flexible), depending on the version ordered (see table). Replacements for modules which are defective or which have to be replaced can be ordered as accessories.

Order characteristic for "inputs/outputs"	Terminal No. (inputs/outputs)			
	20 (+) / 21 (-)	22 (+) / 23 (-)	24 (+) / 25 (-)	26 (+) / 27 (-)
<i>Fixed communication boards (permanent assignment)</i>				
A	-	-	Frequency output	Current output, HART
B	Relay output	Relay output	Frequency output	Current output, HART
F	-	-	-	PROFIBUS PA, Ex i
G	-	-	-	FOUNDATION Fieldbus Ex i
H	-	-	-	PROFIBUS PA
J	-	-	+5V (ext. termination)	PROFIBUS DP
K	-	-	-	FOUNDATION Fieldbus
Q	-	-	Status input	Modbus RS485
R	-	-	Current output 2 Ex i, active	Current output 1 Ex i active, HART
S	-	-	Frequency output Ex i, passive	Current output Ex i Active, HART
T	-	-	Frequency output Ex i, passive	Current output Ex i Passive, HART
U	-	-	Current output 2 Ex i, passive	Current output 1 Ex i passive, HART
<i>Flexible communication boards</i>				
C	Relay output 2	Relay output 1	Frequency output	Current output, HART
D	Status input	Relay output	Frequency output	Current output, HART
E	Status input	Relay output	Current output 2	Current output, HART
L	Status input	Relay output 2	Relay output 1	Current output, HART
M	Status input	Frequency output 2	Frequency output 1	Current output, HART

Order characteristic for "inputs/outputs"	Terminal No. (inputs/outputs)			
	20 (+) / 21 (-)	22 (+) / 23 (-)	24 (+) / 25 (-)	26 (+) / 27 (-)
N	Current output	Frequency output	Status input	Modbus RS485
P	Current output	Frequency output	Status input	PROFIBUS DP
V	Relay output 2	Relay output 1	Status input	PROFIBUS DP
W	Relay output	Current output 3	Current output 2	Current output 1, HART
0	Status input	Current output 3	Current output 2	Current output 1, HART
2	Relay output	Current output 2	Frequency output	Current output 1, HART
3	Current input	Relay output	Current output 2	Current output 1, HART
4	Current input	Relay output	Frequency output	Current output, HART
5	Status input	Current input	Frequency output	Current output, HART
6	Status input	Current input	Current output 2	Current output 1, HART
7	Relay output 2	Relay output 1	Status input	Modbus RS485

**Supply voltage** 85 to 260 V AC, 45 to 65 Hz  
20 to 55 V AC, 45 to 65 Hz  
16 to 62 V DC

**Power consumption** AC: <15 VA (including sensor)  
DC: <15 W (including sensor)  
*Switch-on current:*  

- Max. 13.5 A (<50 ms) at 24 V DC
- Max. 3 A (<5 ms) at 260 V AC

**Power supply failure** **Promass 80**  
Lasting min. 1 power cycle:  

- EEPROM saves measuring system data if the power supply fails
- HistoROM/S-DAT: exchangeable data storage chip with sensor specific data (nominal diameter, serial number, calibration factor, zero point, etc.)

**Promass 83**  
Lasting min. 1 power cycle:  

- EEPROM and T-DAT save the measuring system data if the power supply fails.
- HistoROM/S-DAT: exchangeable data storage chip with sensor specific data (nominal diameter, serial number, calibration factor, zero point, etc.)

Electrical connection

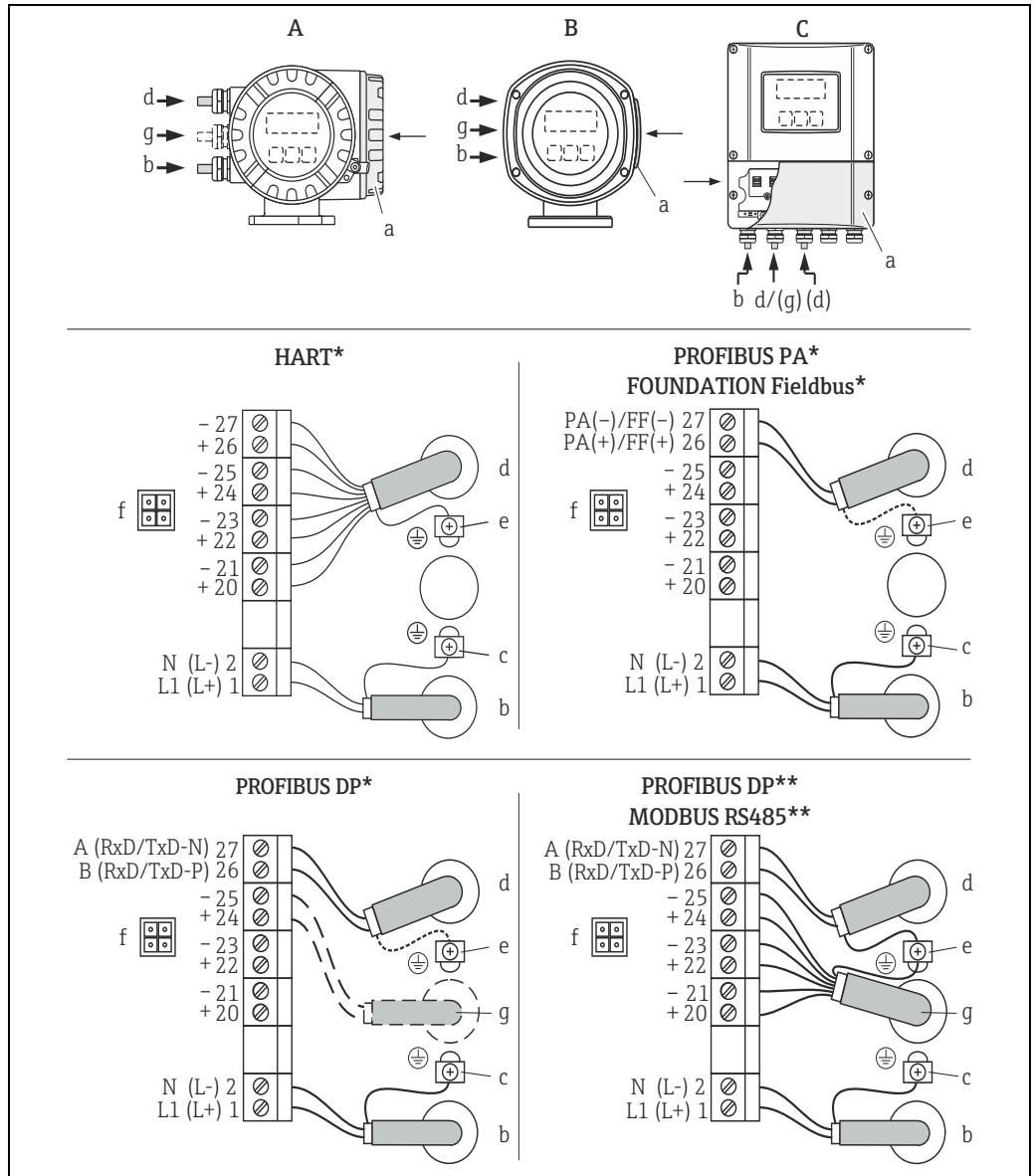

a0002441

Connecting the transmitter, cable cross-section: max. 2.5 mm<sup>2</sup>

- A View A (field housing)
- B View B (Stainless Steel field housing)
- C View C (wall-mount housing)

\*) fixed communication board

\*\*) flexible communication board

a Connection compartment cover

b Cable for power supply: 85 to 260 V AC, 20 to 55 V AC, 16 to 62 V DC

Terminal No. 1: L1 for AC, L+ for DC

Terminal No. 2: N for AC, L- for DC

c Ground terminal for protective ground

d Signal cable: see Terminal assignment → 9

Fieldbus cable:

Terminal No. 26: DP (B) / PA (+) / FF (+) / Modbus RS485 (B) / (PA, FF: with reverse polarity protection)

Terminal No. 27: DP (A) / PA (-) / FF (-) / Modbus RS485 (A) / (PA, FF: with reverse polarity protection)

e Ground terminal for signal cable shield / fieldbus cable / RS485 line

f Service adapter for connecting service interface FXA 193 (Fieldcheck, FieldCare)

g Signal cable: see Terminal assignment → 9

g Cable for external termination (only for PROFIBUS DP with permanent assignment communication board):

Terminal No. 24: +5 V

Terminal No. 25: DGND

## Electrical connection remote version

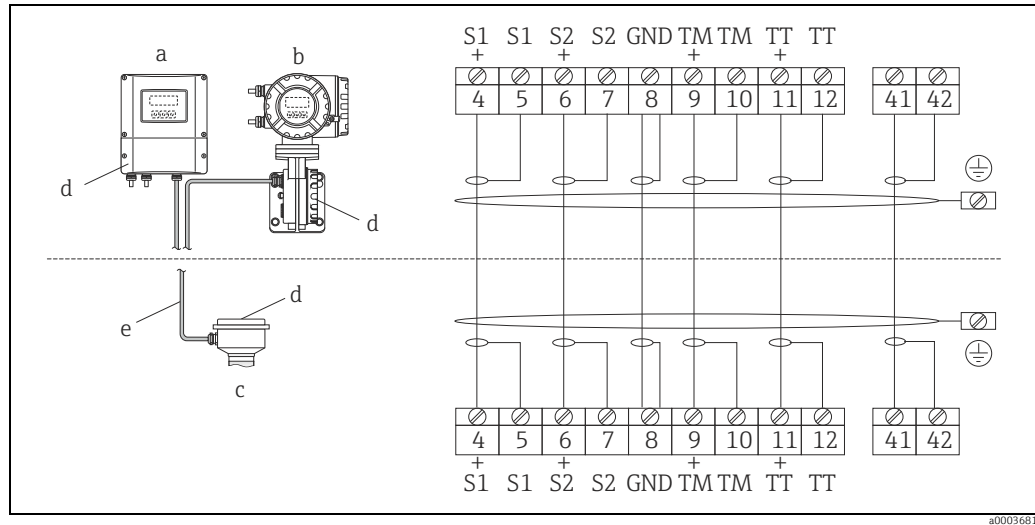

### Connecting the remote version

- a Wall-mount housing: non-hazardous area and ATEX II3G / zone 2 → see separate "Ex documentation"  
 b Wall-mount housing: ATEX II2G / Zone 1 /FM/CSA → see separate "Ex documentation"  
 c Connection housing sensor  
 d Cover for connection compartment or connection housing  
 e Connecting cable

Terminal No.: 4/5 = gray; 6/7 = green; 8 = yellow; 9/10 = pink; 11/12 = white; 41/42 = brown

## Potential equalization

No special measures for potential equalization are required. For instruments for use in hazardous areas, observe the corresponding guidelines in the specific Ex documentation.

## Cable entries

### Power-supply and signal cables (inputs/outputs):

- Cable entry M20 × 1.5 (8 to 12 mm / 0.31" to 0.47")
- Thread for cable entries, ½" NPT, G ½"

### Connecting cable for remote version:

- Cable entry M20 × 1.5 (8 to 12 mm / 0.31" to 0.47")
- Thread for cable entries, ½" NPT, G ½"

## Remote version cable specification

- 6 × 0.38 mm<sup>2</sup> (PVC cable with common shield and individually shielded cores)
- Conductor resistance: ≤ 50 Ω/km (≤ 0.015 Ω/ft)
- Capacitance: core/shield: ≤ 420 pF/m (≤ 128 pF/ft)
- Cable length: max. 20 m (65 ft)
- Permanent operating temperature: max. +105 °C (+221 °F)

### Operation in zones of severe electrical interference:

The measuring device complies with the general safety requirements in accordance with EN 61010, the EMC requirements of EN 61326/A1, and NAMUR recommendation NE 21/43.

## Performance characteristics

## Reference operating conditions

- Error limits following ISO/DIN 11631
- Water with 15 to 45 °C (59 to 113 °F); 2 to 6 bar (29 to 87 psi)
- Data according to calibration protocol
- Accuracy based on accredited calibration rigs according to ISO 17025

To obtain measured errors, use the Applicator sizing tool *Applicator*: → 71.

**Maximum measured error** o.r. = of reading;  $1 \text{ g/cm}^3 = 1 \text{ kg/l}$ ; T = fluid temperature

**Base accuracy**

**Mass flow and volume flow (liquids)**

- Promass 83F:
- $\pm 0.05\%$  o.r. (PremiumCal, for mass flow)
  - $\pm 0.10\%$  o.r.

- Promass 80F:
- $\pm 0.10\%$  o.r. (optional)
  - $\pm 0.15\%$  o.r.

**Mass flow (gases)**

Promass 83F, 80F:  $\pm 0.35\%$  o.r.

**Density (liquids)**

- Reference conditions:  $\pm 0.0005 \text{ g/cm}^3$
- Field density calibration:  $\pm 0.0005 \text{ g/cm}^3$  (valid after field density calibration under process conditions)
- Standard density calibrations:  $\pm 0.01 \text{ g/cm}^3$  (valid over the entire measuring range of the sensor → 21)
- Special density calibration:  $\pm 0.001 \text{ g/cm}^3$  (optional, valid range:  $+5$  to  $+80 \text{ }^\circ\text{C}$  ( $+41$  to  $+176 \text{ }^\circ\text{F}$ ) and  $0$  to  $2.0 \text{ g/cm}^3$ )

**Temperature**

$\pm 0.5 \text{ }^\circ\text{C} \pm 0.005 \cdot T \text{ }^\circ\text{C}$  ( $\pm 1 \text{ }^\circ\text{F} \pm 0.003 \cdot (T - 32) \text{ }^\circ\text{F}$ )

**Zero point stability**

*Promass F (Standard version)*

DN		Zero point stability	
[mm]	[in]	[kg/h]	[lb/min]
8	$\frac{3}{8}$	0.030	0.001
15	$\frac{1}{2}$	0.200	0.007
25	1	0.540	0.019
40	$1\frac{1}{2}$	2.25	0.083
50	2	3.50	0.129
80	3	9.00	0.330
100	4	14.00	0.514
150	6	32.00	1.17
250	10	88.00	3.23

*Promass F (high-temperature version)*

DN		Zero point stability	
[mm]	[in]	[kg/h]	[lb/min]
25	1	1.80	0.0661
50	2	7.00	0.2572
80	3	18.0	0.6610

**Flow values**

Flow values as turndown parameter depending on nominal diameter.

*SI units*

DN [mm]	1:1 [kg/h]	1:10 [kg/h]	1:20 [kg/h]	1:50 [kg/h]	1:100 [kg/h]	1:500 [kg/h]
8	2000	200.0	100.0	40.00	20.00	4.000
15	6500	650.0	625.0	130.0	65.00	13.00
25	18000	1800	900.0	360.0	180.0	36.00
40	45000	4500	2250	900.0	450.0	90.00
50	70000	7000	3500	1400	700.0	140.0
80	180000	18000	9000	3600	1800	360.0
100	350000	35000	17500	7000	3500	700.0
150	800000	80000	40000	16000	8000	1600
250	2200000	220000	110000	44000	22000	4400

*US units*

DN [in]	1:1 [lb/min]	1:10 [lb/min]	1:20 [lb/min]	1:50 [lb/min]	1:100 [lb/min]	1:500 [lb/min]
$\frac{3}{8}$	73.50	7.350	3.675	1.470	0.735	0.147
$\frac{1}{2}$	238.9	23.89	11.95	4.778	2.389	0.478
1	661.5	66.15	33.08	13.23	6.615	1.323
1½	1654	165.4	82.70	33.08	16.54	3.308
2	2573	257.3	128.7	51.46	25.73	5.146
3	6615	661.5	330.8	132.3	66.15	13.23
4	12860	1286	643.0	257.2	128.6	25.72
6	29400	2940	1470	588.0	294.0	58.80
10	80850	8085	4043	1617	808.5	161.7

**Accuracy of outputs**

o.r. = of reading; o.f.s. = of full scale value

The output accuracy must be factored into the measured error if analog outputs are used, but can be ignored for fieldbus outputs (e.g. Modbus RS485, EtherNet/IP).

*Current output*

Accuracy: Max.  $\pm 0.05$  % o.f.s. or  $\pm 5$   $\mu$ A

*Pulse/frequency output*

Genauigkeit: Max.  $\pm 50$  % ppm o.r.

**Repeatability** Design fundamentals →  16.

**Base repeatability**

**Mass flow and volume flow (liquids)**

Promass 83F:

- ±0.025% o.r. (PremiumCal, for mass flow)
- ±0.05% o.r.

Promass 80F: ±0.05% o.r.

**Mass flow (gases)**

Promass 80F, 83F: ±0.25% o.r.

**Density (liquids)**

±0.00025 g/cm<sup>3</sup>

**Temperature**

±0.25 °C ± 0.0025 · T °C (±0.45 °F ± 0.0015 · (T - 32) °F)

**Response time**

- The response time depends on the configuration (damping).
- Response time in the event of erratic changes in the measured variable (only mass flow): after 100 ms 95 % of the full scale value.

**Influence of medium temperature**

When there is a difference between the temperature for zero point adjustment and the process temperature, the typical measured error of the Promass sensor is ±0.0002% of the full scale value/°C (±0.0001% of the full scale value / °F).

**Influence of medium pressure**

The table below shows the effect on accuracy of mass flow due to a difference between calibration pressure and process pressure.

DN		Promass F	Promass F High-temperature version
[mm]	[in]	[% o.r./bar]	[% o.r./bar]
8	3/8	no influence	-
15	1/2	no influence	-
25	1	no influence	no influence
40	1 1/2	-0.003	-
50	2	-0.008	-0.008
80	3	-0.009	-0.009
100	4	-0.007	-
150	6	-0.009	-
250	10	-0.009	-

**Design fundamentals**

o.r. = of reading

BaseAccu = base accuracy in % o.r.

BaseRepeat = base repeatability in % o.r.

MeasValue = measured value (in flow units consistent with the zero point stability value → 13)

ZeroPoint = zero point stability

**Calculation of the maximum measured error depending on flowrate**

Flowrate (in flow units consistent with the zero point stability value → 13)	Maximum measured error in % o.r.
$\geq \frac{\text{ZeroPoint}}{\text{BaseAccu}} \cdot 100$ <small>A0021332</small>	$\pm \text{BaseAccu}$ <small>A0021339</small>
$< \frac{\text{ZeroPoint}}{\text{BaseAccu}} \cdot 100$ <small>A0021333</small>	$\pm \frac{\text{ZeroPoint}}{\text{MeasValue}} \cdot 100$ <small>A0021334</small>

**Calculation of the repeatability depending on flowrate**

Flowrate (in flow units consistent with the zero point stability value → 13)	Repeatability in % o.r.
$\geq \frac{1/2 \cdot \text{ZeroPoint}}{\text{BaseRepeat}} \cdot 100$ <small>A0021335</small>	$\pm \text{BaseRepeat}$ <small>A0021340</small>
$< \frac{1/2 \cdot \text{ZeroPoint}}{\text{BaseRepeat}} \cdot 100$ <small>A0021336</small>	$\pm 1/2 \cdot \frac{\text{ZeroPoint}}{\text{MeasValue}} \cdot 100$ <small>A0021337</small>

**Example for maximum measured error**

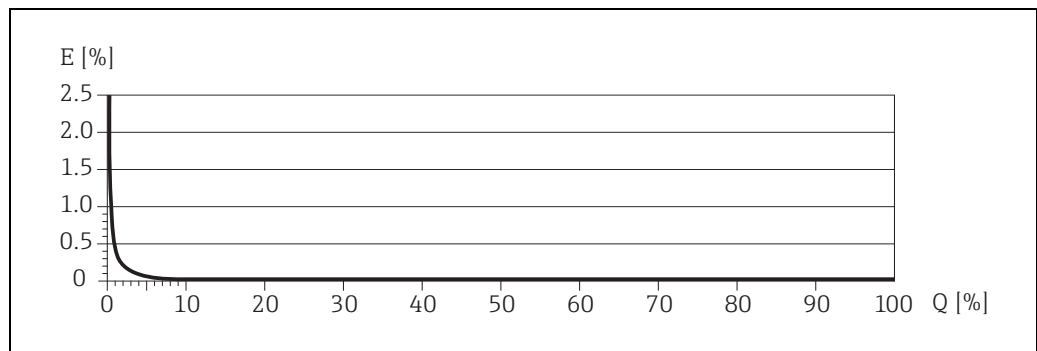

E = Error: Maximum measured error as % o.r. (example Promass 83F)

Q = Flow rate as %



## Installation

### Mounting location

Entrained air or gas bubbles in the measuring tube can result in an increase in measuring errors. **Avoid** the following mounting locations in the pipe:

- Highest point of a pipeline. Risk of air accumulating.
- Directly upstream from a free pipe outlet in a vertical pipeline

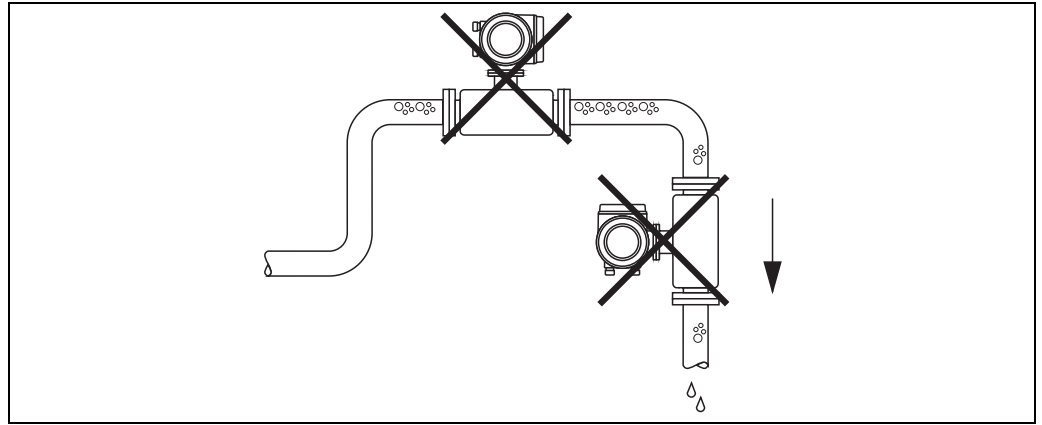

Mounting location

Notwithstanding the above, the installation proposal below permits installation in an open vertical pipeline. Pipe restrictions or the use of an orifice with a smaller cross-section than the nominal diameter prevent the sensor running empty while measurement is in progress.

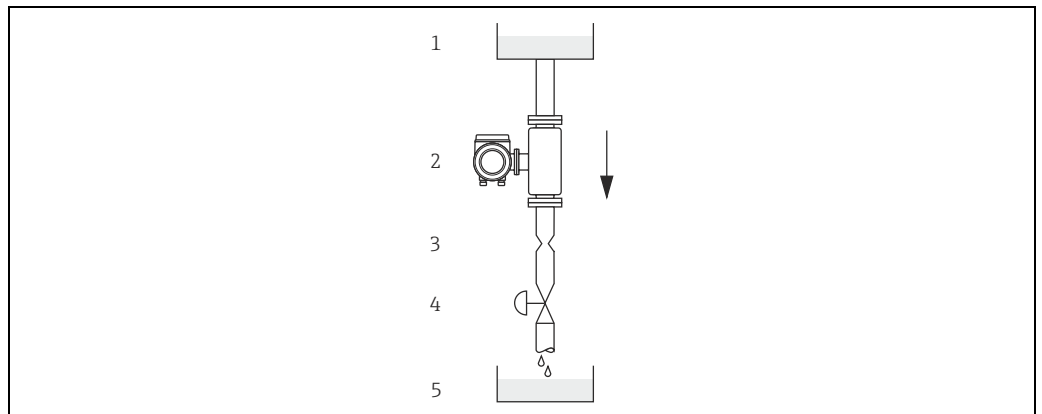

Installation in a down pipe (e.g. for batching applications)

- 1 Supply tank
- 2 Sensor
- 3 Orifice plate, pipe restriction (see table on following page)
- 4 Valve
- 5 Batching tank

DN		ØOrifice plate, pipe restriction	
[mm]	[in]	mm	in
8	$\frac{3}{8}$	6	0.24
15	$\frac{1}{2}$	10	0.40
25	1	14	0.55
40	$1\frac{1}{2}$	22	0.87
50	2	28	1.10
80	3	50	2.00
100	4	65	2.60
150	6	90	3.54
250	10	150	5.91

## Orientation



Make sure that the direction of the arrow on the nameplate of the sensor matches the direction of flow (direction in which the fluid flows through the pipe).

### Vertical (Fig. V)

Recommended orientation with upward direction of flow (Fig. V). When fluid is not flowing, entrained solids will sink down and gases will rise away from the measuring tube. The measuring tubes can be completely drained and protected against solids build-up.

### Horizontal (Fig. H1, H2)

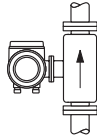
The measuring tubes must be horizontal and beside each other. When installation is correct the transmitter housing is above or below the pipe (Fig. H1, H2). Always avoid having the transmitter housing in the same horizontal plane as the pipe. Please note the special installation instructions →  28.

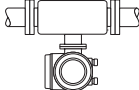
Orientation	Vertical	Horizontal, Transmitter head up	Horizontal, Transmitter head down
	 <i>Fig. V</i> <small>a0004572</small>	 <i>Fig. H1</i> <small>a0004576</small>	 <i>Fig. H2</i> <small>a0004580</small>
Standard version, Compact version	✓✓	✓✓	✓✓ <sup>2</sup>
Standard version, Remote version	✓✓	✓✓	✓✓ <sup>2</sup>
High-temperature version, Compact version	✓✓	✗ <sup>1</sup> TM > 200 °C (> 392°F)	✓✓ <sup>2</sup>
High-temperature version, Remote version	✓✓	✗ <sup>1</sup> TM > 200 °C (> 392°F)	✓✓ <sup>2</sup>

✓✓ = Recommended orientation; ✓ = Orientation recommended in certain situations; ✗ = Impermissible orientation

In order to ensure that the maximum permissible ambient temperature for the transmitter is not exceeded, we recommend the following orientations:

<sup>1</sup> = For fluids with low temperatures, we recommend the horizontal orientation with the transmitter head pointing upwards (Fig. H1) or the vertical orientation (Fig. V).

<sup>2</sup> = For fluids with high-temperatures, >200 °C (>392 °F), we recommend the horizontal orientation with the transmitter head pointing downwards (Fig. H2) or the vertical orientation (Fig. V).

Both measuring tubes are slightly curved. The position of the sensor, therefore, has to be matched to the fluid properties when the sensor is installed horizontally.

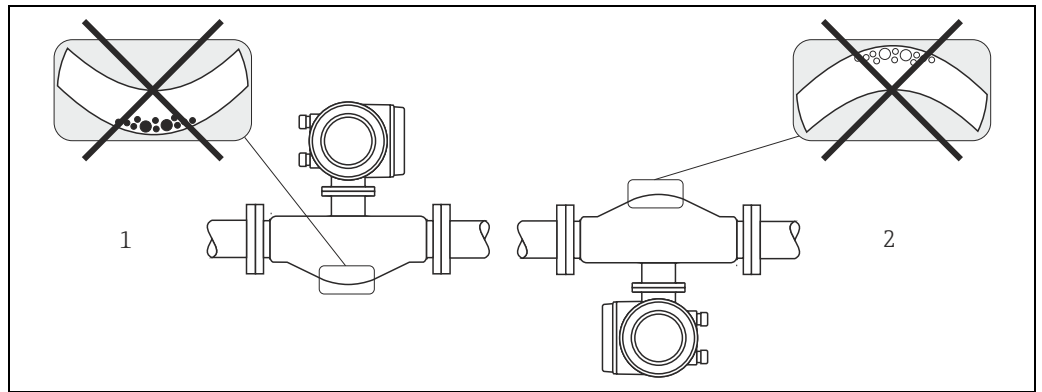

Horizontal installation

- 1 Not suitable for fluids with entrained solids. Risk of solids accumulating.
- 2 Not suitable for outgassing fluids. Risk of air accumulating.

**Installation instructions**

Note the following points:

- No special measures such as supports are necessary. External forces are absorbed by the construction of the instrument, for example the secondary containment.
- The high oscillation frequency of the measuring tubes ensures that the correct operation of the measuring system is not influenced by pipe vibrations.
- No special precautions need to be taken for fittings which create turbulence (valves, elbows, T-pieces, etc.), as long as no cavitation occurs.
- For mechanical reasons and to protect the pipe, support is recommended for heavy sensors.

**Inlet and outlet runs**

There are no installation requirements regarding inlet and outlet runs.

**Length of connecting cable**

max. 20 m (65 ft), remote version

**Special installation instructions**

**Rupture disk**

Make sure that the function and operation of the rupture disk is not impeded through the installation of the device. The position of the rupture disk is indicated on a sticker beside it. For additional information that is relevant to the process (→ 64).

The existing connecting nozzles are not designed for a rinse or pressure monitoring function.

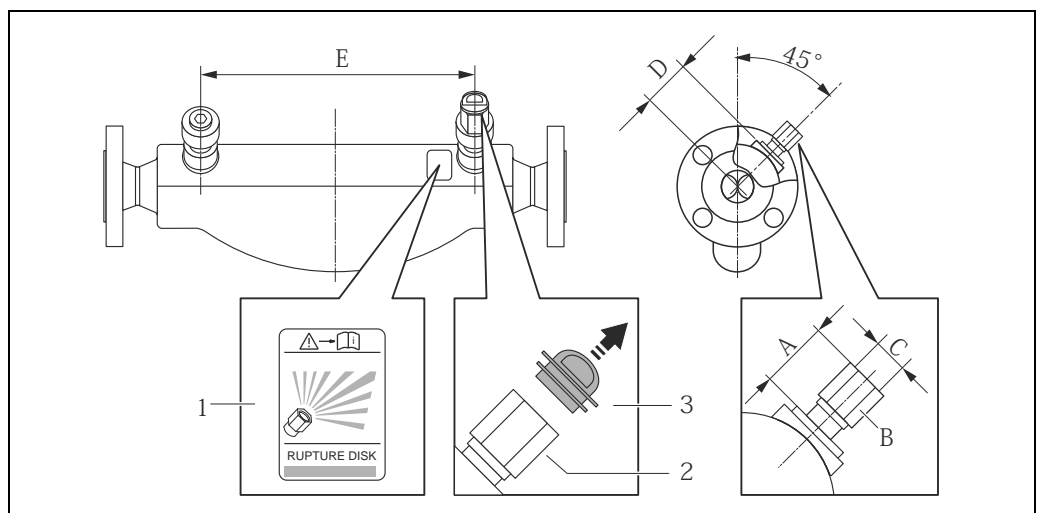

DN 8 to DN 150 (3/8" to 6")

1 = Rupture disk label, 2 = Rupture disk with 1/2" NPT internal thread with 1" width across flat, 3 = Transport protection

## Dimensions

DN		A		B	C	D		E	
[mm]	[in]	[mm]	[in]	[in]	[in]	[mm]	[in]	[mm]	[in]
8	$\frac{3}{8}$	ca. 42	ca. 1.65	SW 1	$\frac{1}{2}$ NPT	62.0	2.44	216	8.50
15	$\frac{1}{2}$	ca. 42	ca. 1.65	SW 1	$\frac{1}{2}$ NPT	62.0	2.44	220	8.66
25	1	ca. 42	ca. 1.65	SW 1	$\frac{1}{2}$ NPT	62.0	2.44	260	10.26
40	1 $\frac{1}{2}$	ca. 42	ca. 1.65	SW 1	$\frac{1}{2}$ NPT	67.0	2.64	310	12.20
50	2	ca. 42	ca. 1.65	SW 1	$\frac{1}{2}$ NPT	79.0	3.11	452	17.78
80	3	ca. 42	ca. 1.65	SW 1	$\frac{1}{2}$ NPT	101.0	3.98	560	22.0
100	4	ca. 42	ca. 1.65	SW 1	$\frac{1}{2}$ NPT	120.0	4.72	684	27.0
150	6	ca. 42	ca. 1.65	SW 1	$\frac{1}{2}$ NPT	141.0	5.55	880	34.6

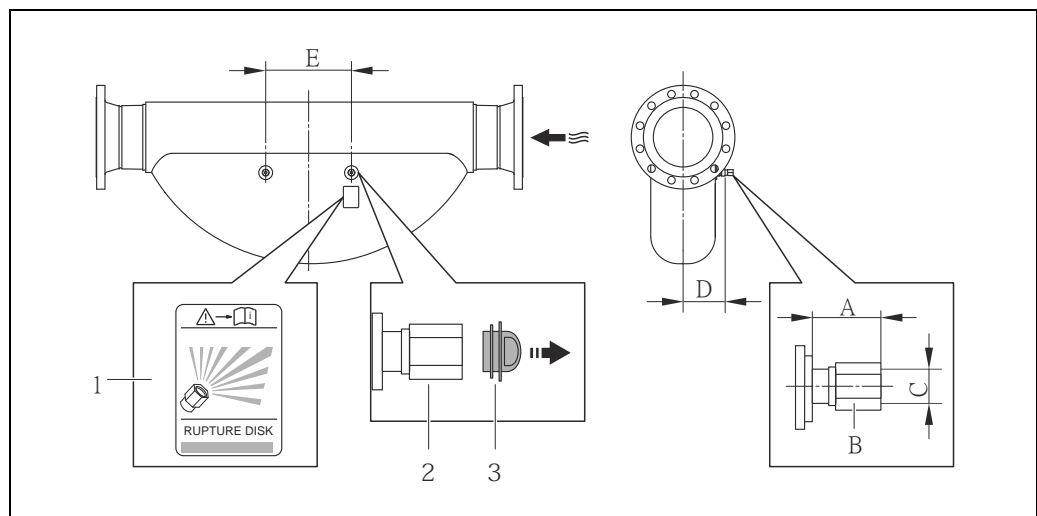

DN 250 (10")

1 = Rupture disk label, 2 = Rupture disk with 1/2" NPT internal thread with 1" width across flat, 3 = Transport protection

## Dimensions

DN		A		B	C	D		E	
[mm]	[in]	[mm]	[in]	[in]	[in]	[mm]	[in]	[mm]	[in]
250	10	ca. 42	ca. 1.65	SW 1	$\frac{1}{2}$ NPT	182	7.17	380	14.96

## Zero point adjustment

All measuring devices are calibrated to state-of-the-art technology. Calibration takes place under reference operating conditions → 12. Consequently, the zero point adjustment is generally not necessary.

Experience shows that the zero point adjustment is advisable only in special cases:

- To achieve highest measuring accuracy also with small flow rates
- Under extreme process or operating conditions (e.g. very high process temperatures or very high-viscosity fluids).

---

## Environment

---

<b>Ambient temperature range</b>	Sensor and transmitter <ul style="list-style-type: none"> <li>■ Standard: -20 to +60 °C (-4 to +140 °F)</li> <li>■ Optional: -40 to +60 °C (-40 to +140 °F)</li> </ul>
	Note! <ul style="list-style-type: none"> <li>■ Install the device at a shady location. Avoid direct sunlight, particularly in warm climatic regions.</li> <li>■ At ambient temperatures below -20 °C (-4 °F) the readability of the display may be impaired.</li> </ul>
<b>Storage temperature</b>	-40 to +80 °C (-40 to +175 °F), preferably +20 °C (+68 °F)
<b>Degree of protection</b>	Standard: IP 67 (NEMA 4X) for transmitter and sensor
<b>Shock resistance</b>	In accordance with IEC 68-2-31
<b>Vibration resistance</b>	Acceleration up to 1 g, 10 to 150 Hz, following IEC 68-2-6
<b>Electromagnetic compatibility (EMC)</b>	To IEC/EN 61326 and NAMUR Recommendation NE 21

---

## Process

---

<b>Medium temperature range</b>	<b>Sensor</b> <ul style="list-style-type: none"> <li>■ Standard version: -50 to +200 °C (-58 to +392 °F)</li> <li>■ High-temperature version: -50 to +350 °C (-58 to +662 °F)</li> </ul>
<b>Medium density</b>	0 to 5000 kg/m <sup>3</sup> (0 to 312 lb/ft <sup>3</sup> )
<b>Medium pressure range (nominal pressure)</b>	<b>Flanges</b> <ul style="list-style-type: none"> <li>■ Standard version:             <ul style="list-style-type: none"> <li>- according to DIN PN 16 to 100</li> <li>- according to ASME B16.5 Cl 150, Cl 300, Cl 600</li> <li>- JIS 10K, 20K, 40K, 63K</li> </ul> </li> <li>■ High temperature version:             <ul style="list-style-type: none"> <li>- according to DIN PN 40, 64, 100</li> <li>- according to ASME B16.5 Cl 150, Cl 300, Cl 600</li> <li>- JIS 10K, 20K, 63K</li> </ul> </li> </ul>

### Secondary containment pressure rating

The sensor housing is filled with dry nitrogen and protects the electronics and mechanics inside.

DN		Secondary containment rating (designed with a safety factor $\geq 4$ )		Burst pressure of secondary containment	
[mm]	[in]	[bar]	[psi]	[bar]	[psi]
8	$\frac{3}{8}$	40	580	255	3695
15	$\frac{1}{2}$	40	580	200	2900
25	1	40	580	280	4060
40	$1\frac{1}{2}$	40	580	180	3610
50	2	40	580	195	2825
80	3	25	362	105	1520
100	4	16	232	85	1230
150	6	16	232	80	1160
250	10	10	145	57	825



#### Note!

In case a danger of measuring tube failure exists due to process characteristics, e.g. with corrosive process fluids, we recommend the use of sensors whose secondary containment is equipped with special pressure monitoring connections (ordering option). With the help of these connections, fluid collected in the secondary containment in the event of tube failure can be bled off. This is especially important in high pressure gas applications. These connections can also be used for gas circulation and/or gas detection (dimensions → 30).

Do not open the purge connections unless the containment can be filled immediately with a dry inert gas. Use only low gauge pressure to purge. Maximum pressure: 5 bar (72.5 psi).

If a device equipped with purge connections is connected to the purge system, the maximum pressure rating is defined by the purge system itself or the device, whichever is lower.

If the device is equipped with a rupture disk, the maximum pressure rating is defined by the rupture disk properties (→ 64).

**Pressure-temperature ratings**



**Warning!**

The following pressure-temperature-ratings refer to the entire sensor and not just the process connection.

**Flange connection according to EN 1092-1 (DIN 2501)**

Flange material: 1.4404 (F316/F316L), Alloy C22

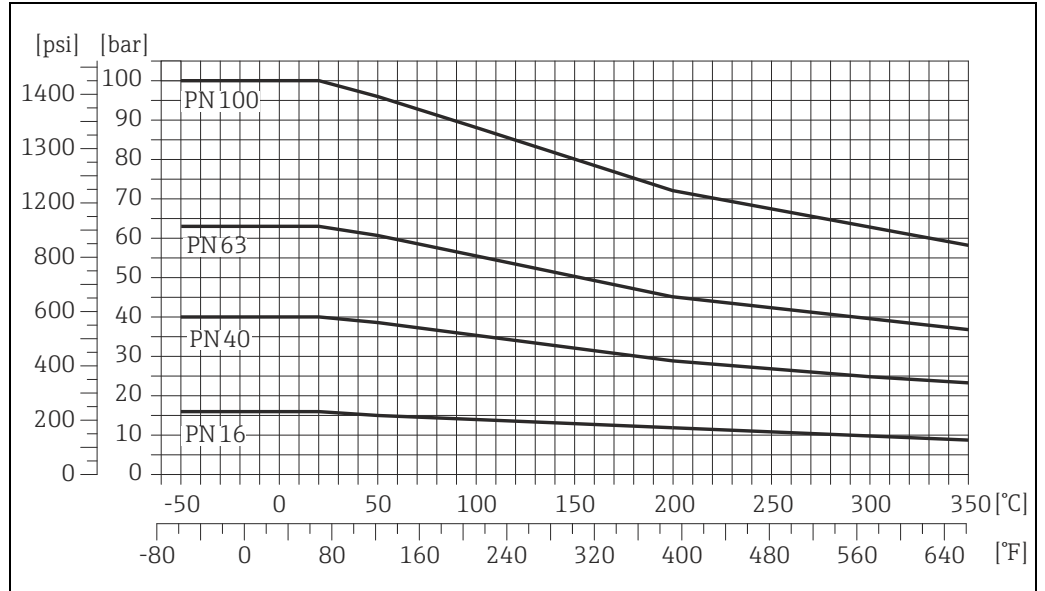

The values for the temperature range from +200 °C to +350 °C (+392 °F to +662 °F) are exclusively valid for the high-temperature version.

**Flange connection according to ASME B16.5**

Flange material: 1.4404 (F316/F316L), standard version

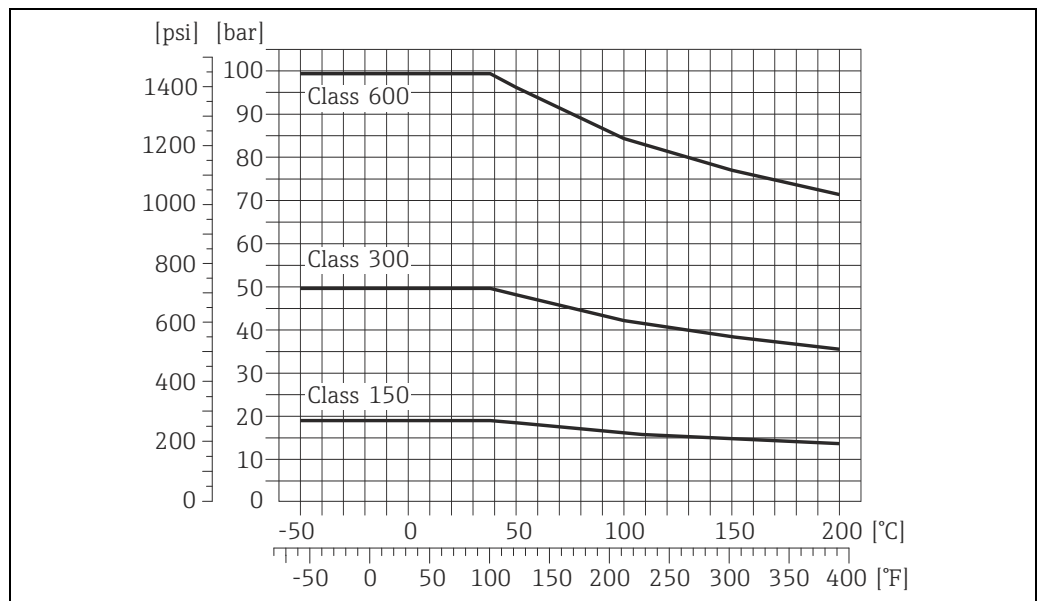

Flange material: 1.4404 (F316/F316L), high-temperature version

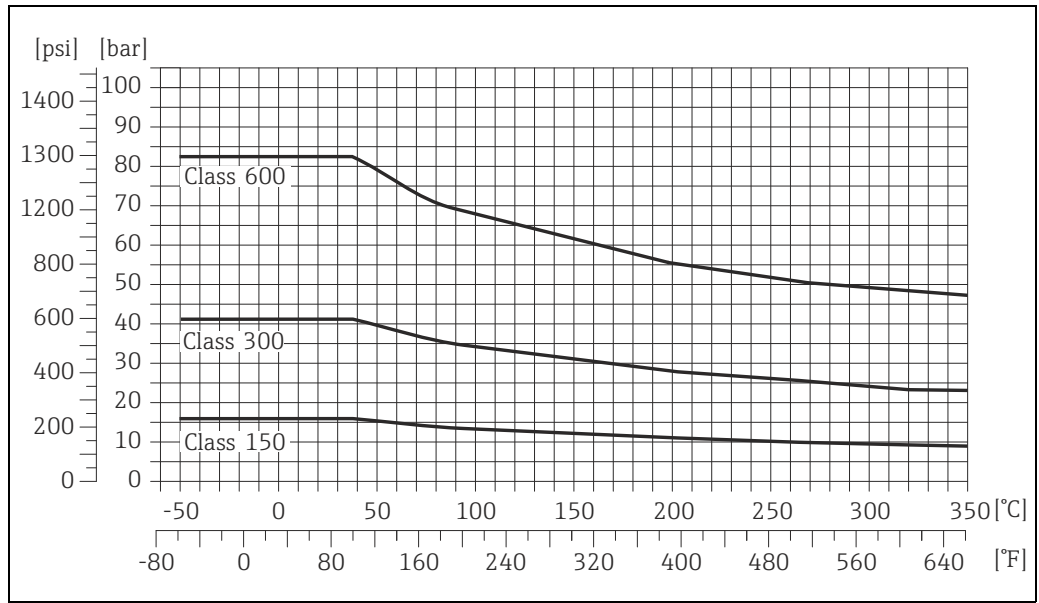

The values for the temperature range are exclusively valid for high-temperature version.

Flange material: Alloy C22, high-temperature version

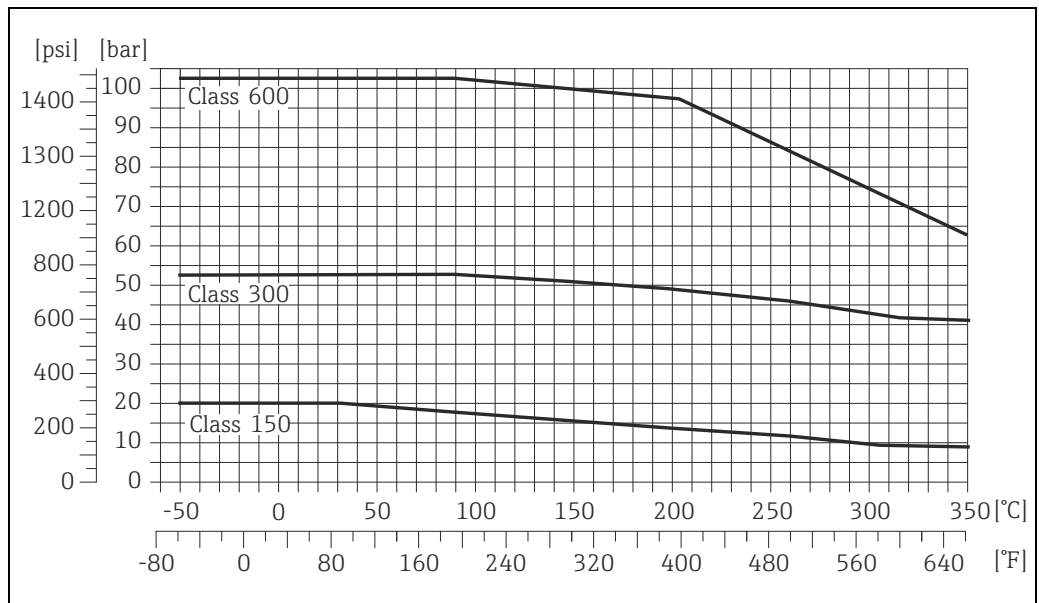

The values for the temperature range are exclusively valid for high-temperature version.



**Flange connection to JIS B2220**

Flange material: 1.4404 (F316/F316L), Alloy C22

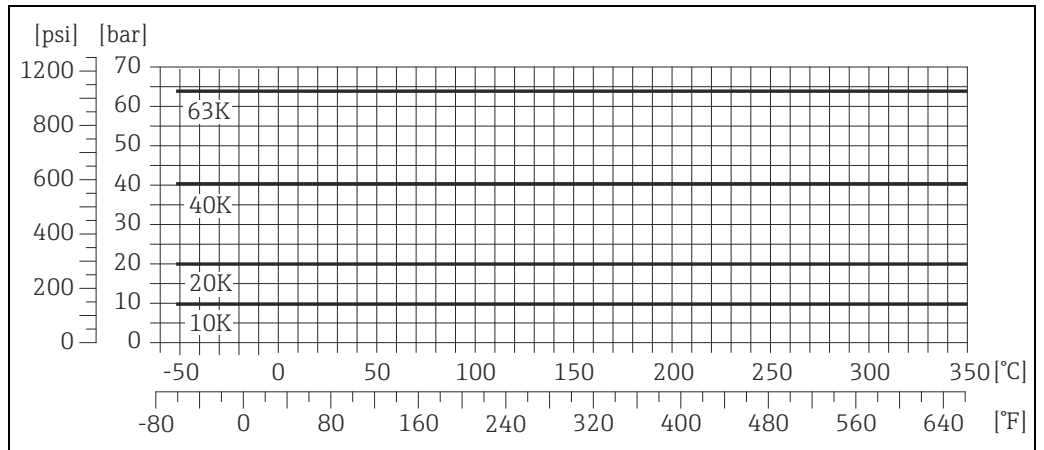

The values for the temperature range from +200 °C to +350 °C (+392 °F to +662 °F) are exclusively valid for high-temperature version.

**Lap joint flange according to EN 1092-1 (DIN 2501)**

Flange material: 1.4301 (F304); wetted parts: Alloy C22

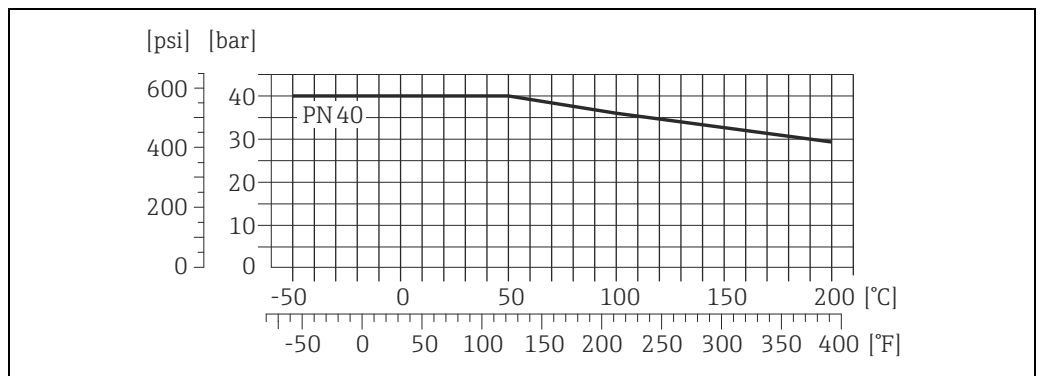

**Lap joint flange according to ASME B16.5**

Flange material: 1.4301 (F304); wetted parts: Alloy C22

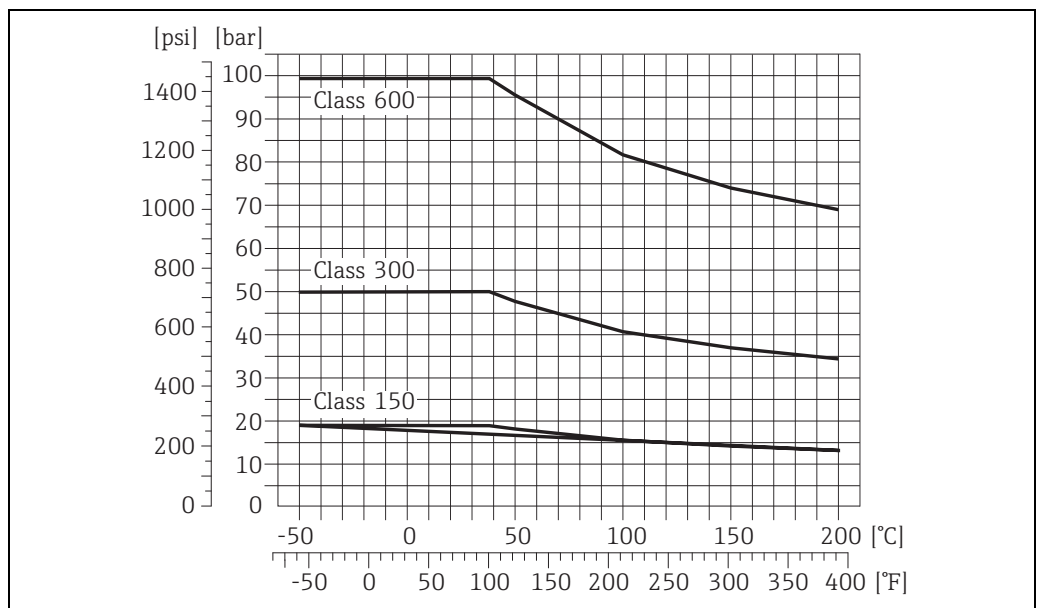

**Lap joint flange JIS B2220**

Flange material: 1.4301 (F304); wetted parts: Alloy C22

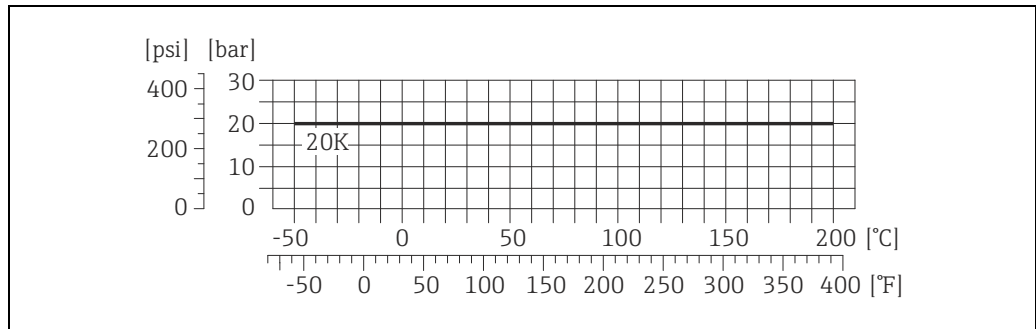

A0021346-EN

**Process connection to DIN 11851**

Connection material: 1.4404 (316/316L)

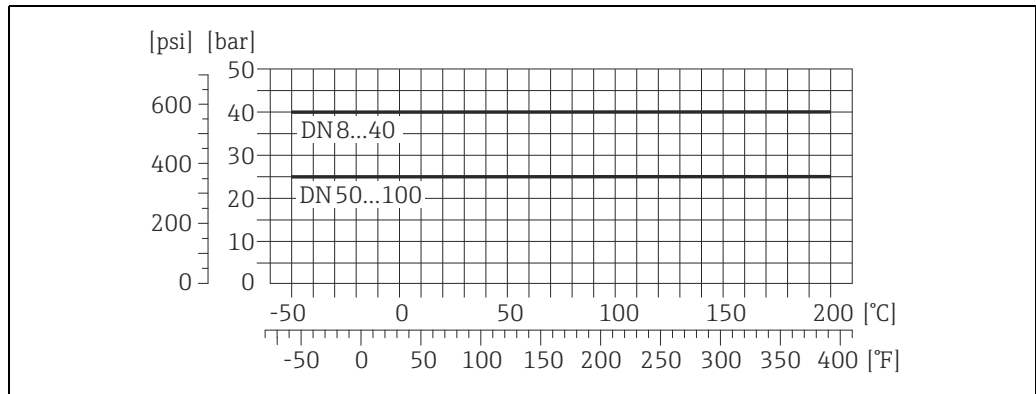

A0021027-EN

DIN 11851 allows for applications up to +140 °C (+284 °F) if suitable sealing materials are used. Please take this into account when selecting seals and counterparts as these components can limit the pressure and temperature range.

**Process connection to SMS 1145**

Connection material: 1.4404 (316/316L)

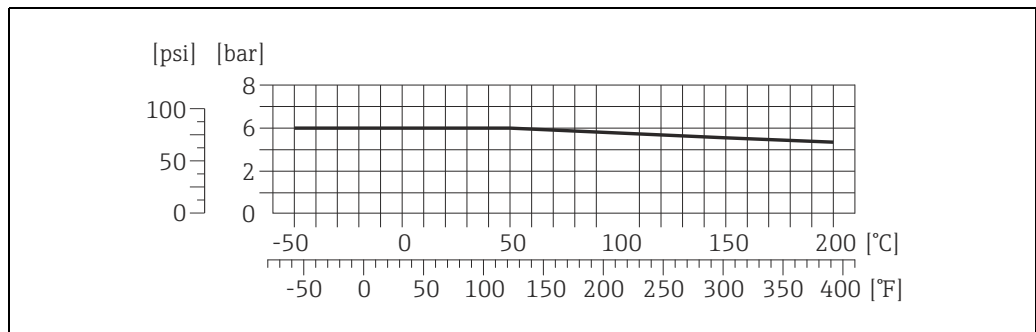

A0013056

SMS 1145 allows for applications up to 6 bar (87 psi) if suitable sealing materials are used. Please take this into account when selecting seals and counterparts as these components can limit the pressure and temperature range.

**Tri-Clamp process connection**

The Clamp connections are suited up to a maximum pressure of 16 bar (232 psi). Please observe the operating limits of the clamp and seal used as they could be under 16 bar (232 psi). The clamp and the seal are not included in the scope of supply.

**Aseptic threaded connection to DIN 11864-1 Form A**

Connection material: 1.4404 (316/316L)

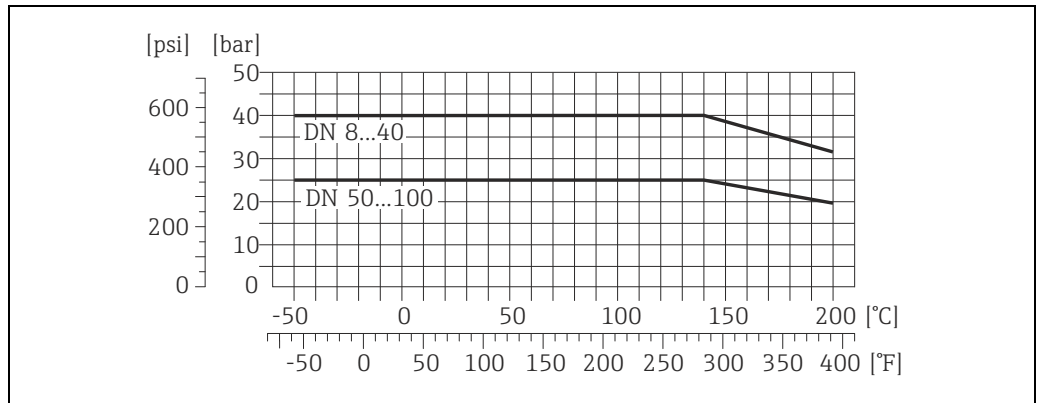

A0012809-DE

**Flange connection to DIN 11864-2 Form A (aseptic flat flange with groove)**

Flange material: 1.4404 (316/316L)

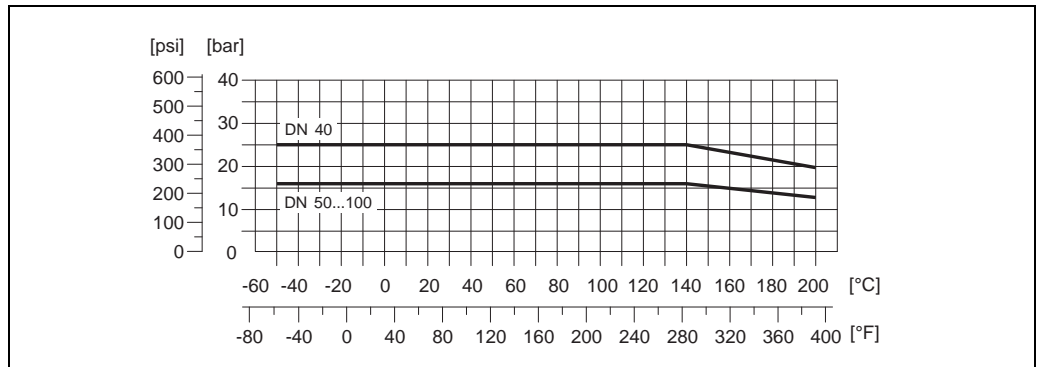

A0004659

**Threaded hygienic connection to ISO 2853**

Connection material: 1.4404 (316/316L)

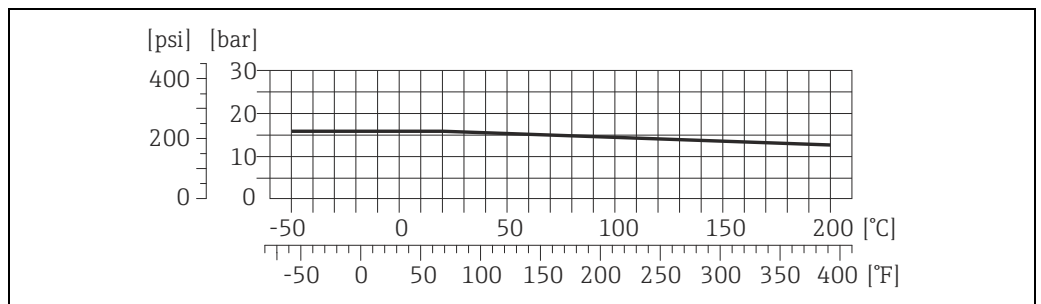

A0020964-EN

**VCO process connection**

Connection material: 1.4404 (316/316L)

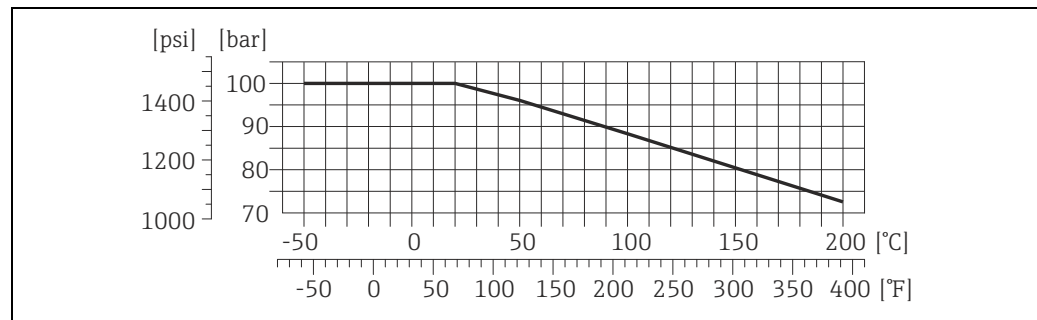

A0020963-EN

**Rupture disk**

To increase the level of safety, a device version with a rupture disk with a triggering pressure of 10 to 15 bar (145 to 217.5 psi) can be used. Special mounting instructions: (→ [19](#)). Rupture disks cannot be combined with the separately available heating jacket (→ [70](#)).

**Limiting flow**

See information in the "Measuring range" Section → [5](#)

Select nominal diameter by optimizing between required flow range and permissible pressure loss. An overview of max. possible full scale values can be found in the "Measuring range" Section.

- The minimum recommended full scale value is approx. 1/20 of the max. full scale value.
- In most applications, 20 to 50% of the maximum full scale value can be considered ideal.
- Select a lower full scale value for abrasive substances such as fluids with entrained solids (flow velocity <math>< 1 \text{ m/s}</math> (<math>< 3 \text{ ft/s}</math>)).
- For gas measurement the following rules apply:
  - Flow velocity in the measuring tubes should not be more than half the sonic velocity (0.5 Mach).
  - The maximum mass flow depends on the density of the gas: formula → [5](#)

**Pressure loss**

To calculate the pressure loss, use the *Applicator* sizing tool (→ [70](#)).

**System pressure**

It is important to ensure that cavitation does not occur, because it would influence the oscillation of the measuring tube. No special measures need to be taken for fluids which have properties similar to water under normal conditions.

In the case of liquids with a low boiling point (hydrocarbons, solvents, liquefied gases) or in suction lines, it is important to ensure that pressure does not drop below the vapor pressure and that the liquid does not start to boil. It is also important to ensure that the gases that occur naturally in many liquids do not outgas. Such effects can be prevented when system pressure is sufficiently high.

For this reason, the following mounting locations are preferred:

- Downstream from pumps (no risk of partial vacuum)
- At the lowest point in a vertical pipe

## Thermal insulation

Some fluids require suitable measures to avoid loss of heat at the sensor. A wide range of materials can be used to provide the required thermal insulation.

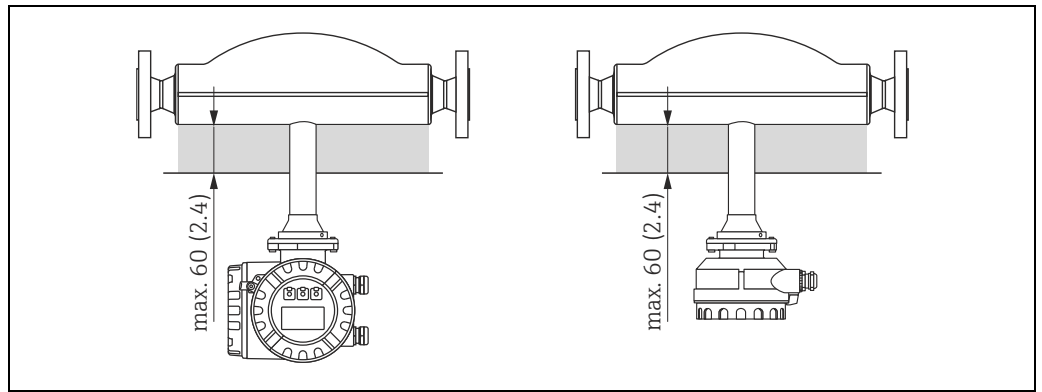

High-temperature version: maximum insulation thickness of 60 mm (2.4") in the area of the electronics/neck

If the Promass F high-temperature version is installed horizontally (with transmitter head pointing upwards), an insulation thickness of min. 10 mm (0.4") is recommended to reduce convection. The maximum insulation thickness of 60 mm (2.4") must be observed.

## Heating



Some fluids require suitable measures to avoid loss of heat at the sensor. Heating can be electric, e.g. with heated elements, or by means of hot water or steam pipes made of copper or heating jackets.

### Caution!

- Risk of electronics overheating! Make sure that the maximum permissible ambient temperature for the transmitter is not exceeded. Consequently, make sure that the adapter between sensor and transmitter and the connection housing of the remote version always remain free of insulating material. Note that a certain orientation might be required, depending on the fluid temperature → 21.
- With a fluid temperature between +200 °C to +350 °C (+392 °F to +662 °F) the remote version of the high-temperature version is preferable.
- When using electrical heat tracing whose heat is regulated using phase control or by pulse packs, it cannot be ruled out that the measured values are influenced by magnetic fields which may occur, (i.e. at values greater than those permitted by the EC standard (Sinus 30 A/m)). In such cases, the sensor must be magnetically shielded.  
The secondary containment can be shielded with tin plates or electric sheets without privileged direction (e.g. V330-35A) with the following properties:
  - Relative magnetic permeability  $\mu_r \geq 300$
  - Plate thickness  $d \geq 0.35 \text{ mm}$  ( $d \geq 0.014''$ )
- Information on permissible temperature ranges → 21

Special heating jackets which can be ordered as accessories from Endress+Hauser are available for the sensors.

## Mechanical construction

### Design, dimensions

<b>Dimensions:</b>	
Field housing compact version, powder-coated die-cast aluminum	→ 31
Transmitter compact version, stainless steel	→ 33
Transmitter remote version, connection housing (II2G/Zone 1)	→ 34
Transmitter remote version, wall-mount housing (non Ex-zone and II3G/Zone 2)	→ 35
Sensor remote version, connection housing	→ 36
Sensor remote version, connection housing with an extended neck	→ 37
High-temperature version (compact)	→ 38
High-temperature version (remote)	→ 38
<b>Process connections in SI units</b>	
Flange connections EN (DIN)	→ 40
Flange connections ASME B16.5	→ 42
Flange connections JIS B2220	→ 44
Lap joint flange EN (DIN)	→ 47
Lap joint flange ASME B16.6	→ 47
Lap joint flange JIS	→ 48
Tri-Clamp	→ 49
DIN 11851 (threaded hygienic connection)	→ 50
DIN 11864-1 Form A (aseptic threaded connection)	→ 51
DIN 11864-2 Form A (aseptic flat flange with groove)	→ 52
ISO 2853 (threaded hygienic connection)	→ 53
SMS 1145 (threaded hygienic connection)	→ 54
VCO connections	→ 55
<b>Process connection in US units</b>	
Flange connections ASME B16.5	→ 56
Tri-Clamp	→ 61
SMS 1145 (Threaded hygienic connection)	→ 62
VCO connections	→ 63
<b>Purge connections / secondary containment monitoring</b>	→ 64

**Field housing compact version, powder-coated die-cast aluminum**

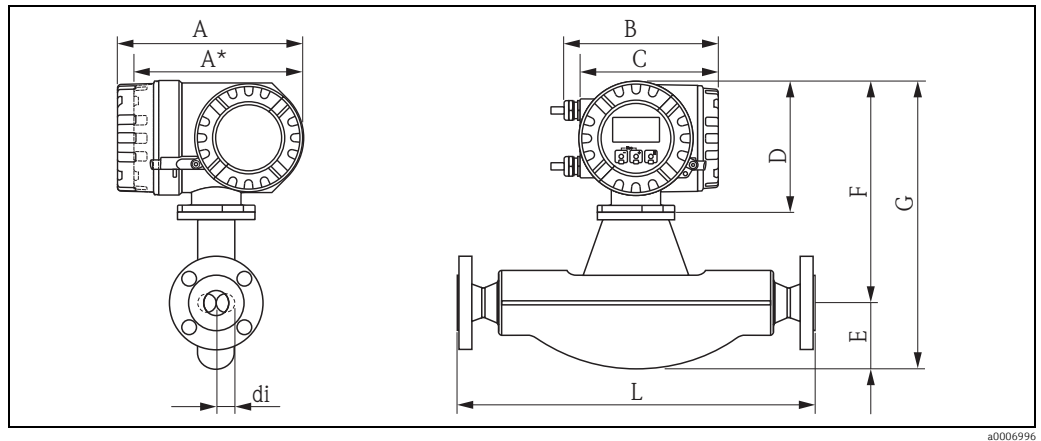

*Dimensions in SI units*

DN	A	A*	B	C	D	E	F	G	L	di
8	227	207	187	168	160	75	266	341	1)	1)
15	227	207	187	168	160	75	266	341	1)	1)
25	227	207	187	168	160	75	266	341	1)	1)
40	227	207	187	168	160	105	271	376	1)	1)
50	227	207	187	168	160	141	283	424	1)	1)
80	227	207	187	168	160	200	305	505	1)	1)
100	227	207	187	168	160	254	324	578	1)	1)
150	227	207	187	168	160	378	362	740	1)	1)
250	227	207	187	168	160	548	390	938	1)	1)

\* Blind version (without local display)

<sup>1)</sup> dependent on respective process connection

All dimensions in [mm]

*Dimensions in US units*

DN	A	A*	B	C	D	E	F	G	L	di
3/8"	8.94	8.15	7.68	6.61	6.30	2.95	10.5	13.4	1)	1)
1/2"	8.94	8.15	7.68	6.61	6.30	2.95	10.5	13.4	1)	1)
1"	8.94	8.15	7.68	6.61	6.30	2.95	10.5	13.4	1)	1)
1 1/2"	8.94	8.15	7.68	6.61	6.30	4.13	10.7	14.8	1)	1)
2"	8.94	8.15	7.68	6.61	6.30	5.55	11.1	16.7	1)	1)
3"	8.94	8.15	7.68	6.61	6.30	7.87	12.0	19.9	1)	1)
4"	8.94	8.15	7.68	6.61	6.30	10.0	12.8	22.8	1)	1)
6"	8.94	8.15	7.68	6.61	6.30	14.9	14.3	29.1	1)	1)
10"	8.94	8.15	7.68	6.61	6.30	21.6	15.4	36.9	1)	1)

\* Blind version (without local display)

<sup>1)</sup> dependent on respective process connection

All dimensions in [in]



Note!

Dimensions for transmitters II2G/Zone 1 → 34.

## Field housing compact version (II2G/Zone 1), powder-coated die-cast aluminum

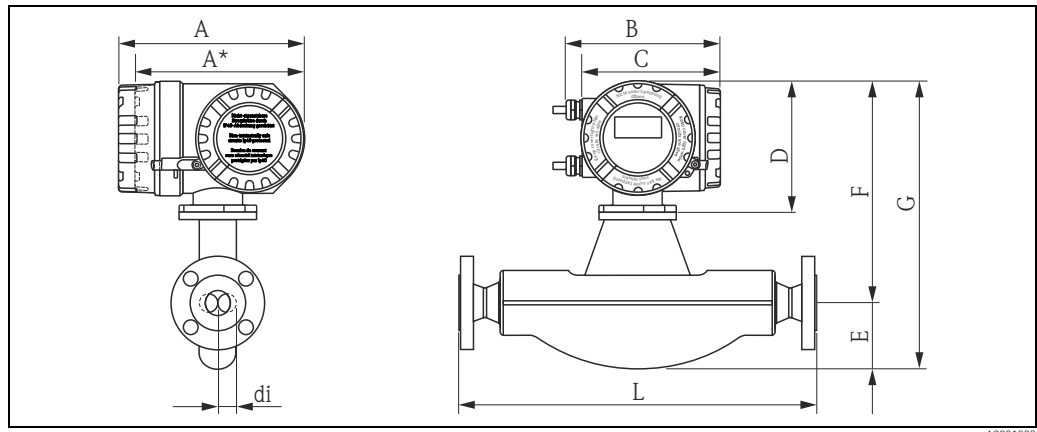

Dimension unit in mm (in)

## Dimensions in SI units

DN	A	A*	B	C	D	E	F	G	L	di
8	240	217	206	186	178	75	284	359	1)	1)
15	240	217	206	186	178	75	284	359	1)	1)
25	240	217	206	186	178	75	284	359	1)	1)
40	240	217	206	186	178	105	289	394	1)	1)
50	240	217	206	186	178	141	301	442	1)	1)
80	240	217	206	186	178	200	323	523	1)	1)
100	240	217	206	186	178	254	342	596	1)	1)
150	240	217	206	186	178	378	380	758	1)	1)
250	240	217	206	186	178	548	408	956	1)	1)

\* Blind version (without local display)

<sup>1)</sup> dependent on respective process connection

All dimensions in [mm]

## Dimensions in US units

DN	A	A*	B	C	D	E	F	G	L	di
3/8"	9.45	8.54	8.11	7.32	7.01	2.95	11.2	14.1	1)	1)
1/2"	9.45	8.54	8.11	7.32	7.01	2.95	11.2	14.1	1)	1)
1"	9.45	8.54	8.11	7.32	7.01	2.95	11.2	14.1	1)	1)
1 1/2"	9.45	8.54	8.11	7.32	7.01	4.13	11.4	15.5	1)	1)
2"	9.45	8.54	8.11	7.32	7.01	5.55	11.8	17.4	1)	1)
3"	9.45	8.54	8.11	7.32	7.01	7.87	12.7	20.6	1)	1)
4"	9.45	8.54	8.11	7.32	7.01	10.0	13.5	23.5	1)	1)
6"	9.45	8.54	8.11	7.32	7.01	14.9	15.0	29.8	1)	1)
10"	9.45	8.54	8.11	7.32	7.01	21.6	16.1	37.6	1)	1)

\* Blind version (without local display)

<sup>1)</sup> dependent on respective process connection

All dimensions in [in]



Note!

Dimensions for transmitters II2G/Zone 1 → 34.



**Transmitter compact version, stainless steel**

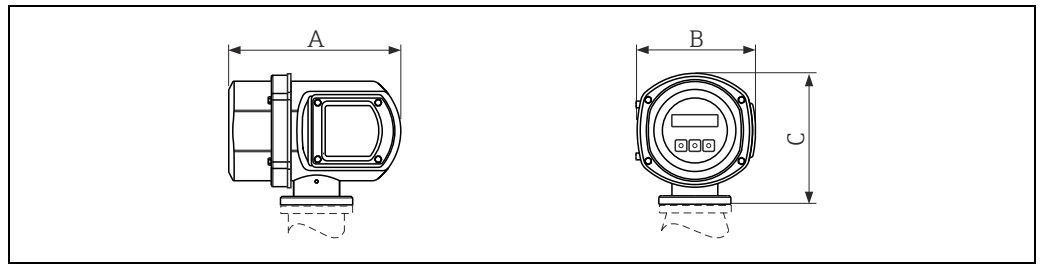

a0002245

*Dimensions in SI and US units*

A		B		C	
[mm]	[in]	[mm]	[in]	[mm]	[in]
225	8.86	153	6.02	168	6.61

**Transmitter compact version (II2G/Zone 1), stainless steel**

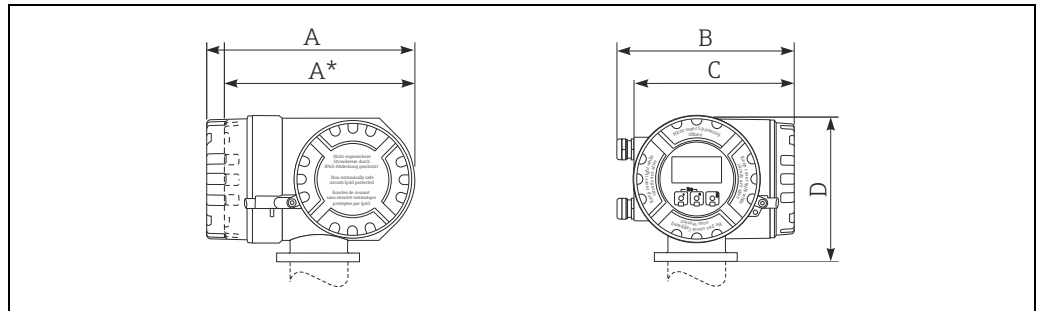

A0022059

*Dimensions in SI and US units*

A		A*		B		C		D	
[mm]	[in]	[mm]	[in]	[mm]	[in]	[mm]	[in]	[mm]	[in]
227	8.94	207	8.15	187	7.68	168	6.61	160	6.30

## Transmitter remote version, connection housing (II2G/Zone 1)

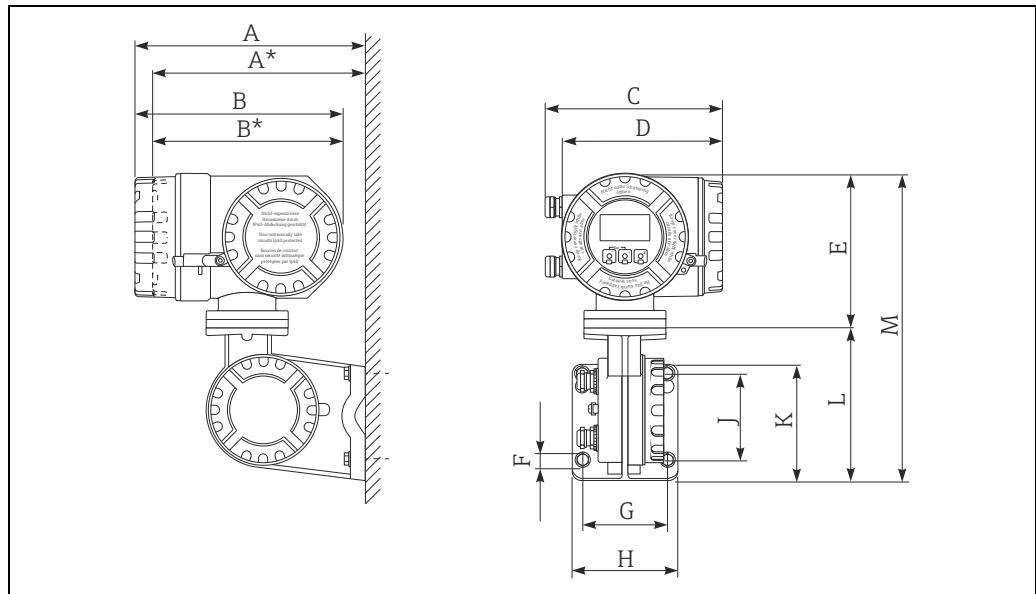

a0002128

## Dimensions in SI units

A	A*	B	B*	C	D	E	F Ø	G	H	J	K	L	M
265	242	240	217	206	186	178	8.6 (M8)	100	130	100	144	170	348

\* Blind version (without display)  
All dimensions in [mm]

## Dimensions in US units

A	A*	B	B*	C	D	E	F Ø	G	H	J	K	L	M
10.4	9.53	9.45	8.54	8.11	7.32	7.01	0.34 (M8)	3.94	5.12	3.94	5.67	6.69	13.7

\* Blind version (without display)  
All dimensions in [in]

**Transmitter remote version, wall-mount housing (non Ex-zone and II3G/Zone 2)**

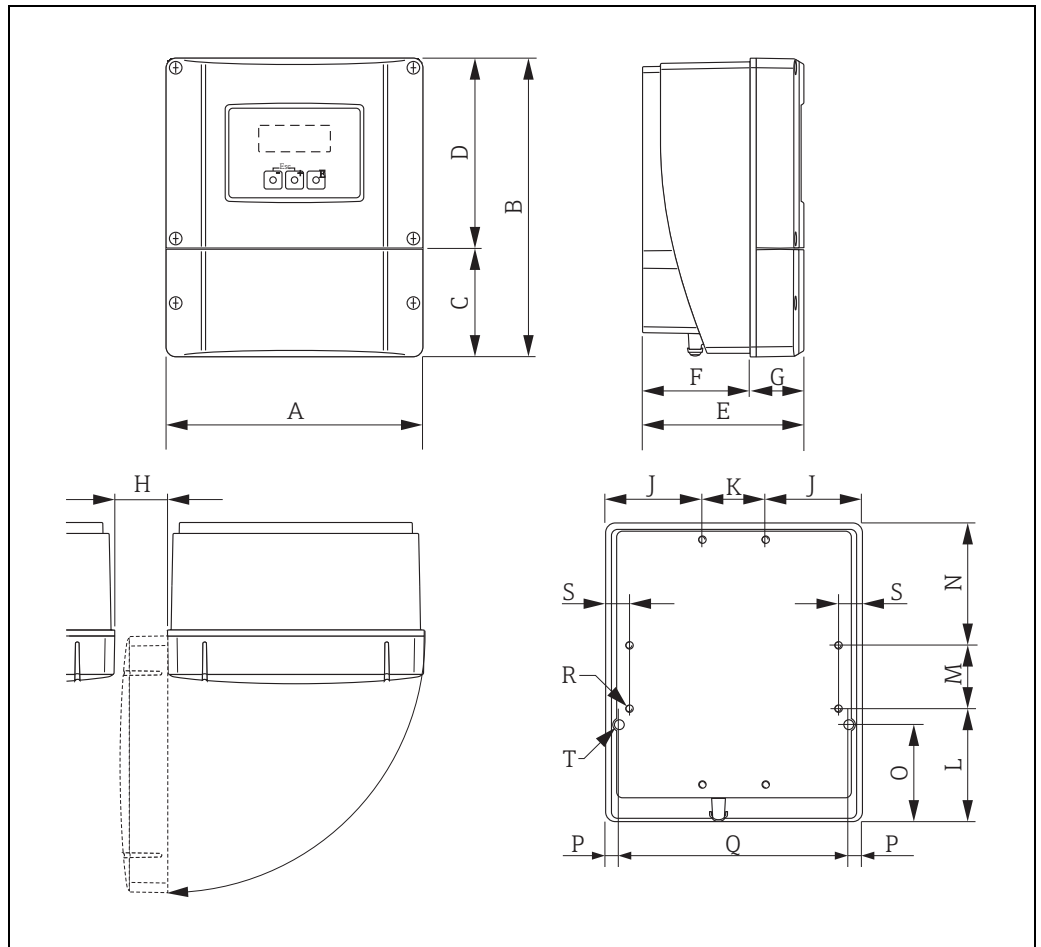

a0001150

*Dimensions (SI units)*

A	B	C	D	E	F	G	H	J	K
215	250	90.5	159.5	135	90	45	> 50	81	53
L	M	N	O	P	Q	R	S	T <sup>1)</sup>	
95	53	102	81.5	11.5	192	8 × M5	20	2 × Ø6.5	

<sup>1)</sup> Securing screw for wall mounting: M6 (screw head max. 10.5 mm)

All dimensions in [mm]

*Dimensions (US units)*

A	B	C	D	E	F	G	H	J	K
8.46	9.84	3.56	6.27	5.31	3.54	1.77	> 1.97	3.18	2.08
L	M	N	O	P	Q	R	S	T <sup>1)</sup>	
3.74	2.08	4.01	3.20	0.45	7.55	8 × M5	0.79	2 × Ø0.26	

<sup>1)</sup> Securing screw for wall mounting: M6 (screw head max. 0.41")

All dimensions in [in]

## Sensor remote version, connection housing

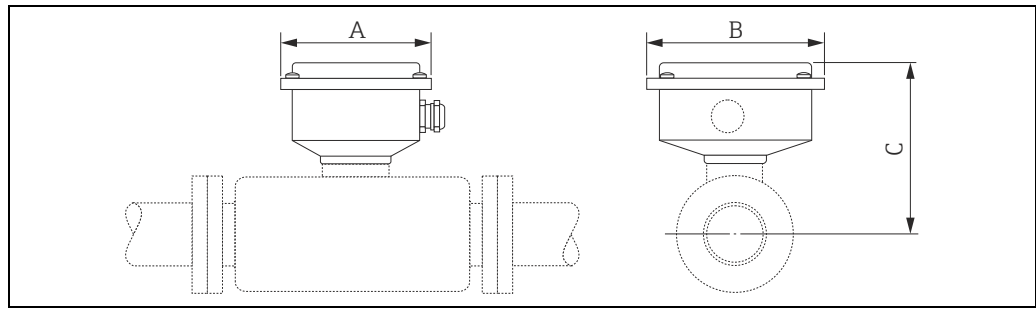

## Dimensions in SI units

DN	A	B	C
8	118.5	137.5	113
15	118.5	137.5	113
25	118.5	137.5	113
40	118.5	137.5	118
50	118.5	137.5	130
80	118.5	137.5	152
100	118.5	137.5	171
150	118.5	137.5	209
250	118.5	137.5	237

All dimensions in [mm]

## Dimensions in US units

DN	A	B	C
3/8"	4.67	5.41	4.52
1/2"	4.67	5.41	4.52
1"	4.67	5.41	4.52
1 1/2"	4.67	5.41	4.72
2"	4.67	5.41	5.20
3"	4.67	5.41	6.08
4"	4.67	5.41	6.84
6"	4.67	5.41	8.36
10"	4.67	5.41	9.48

All dimensions in [in]

**Sensor remote version, connection housing with an extended neck**



Note!

Use this version in case of insulation or application of heating jacket.

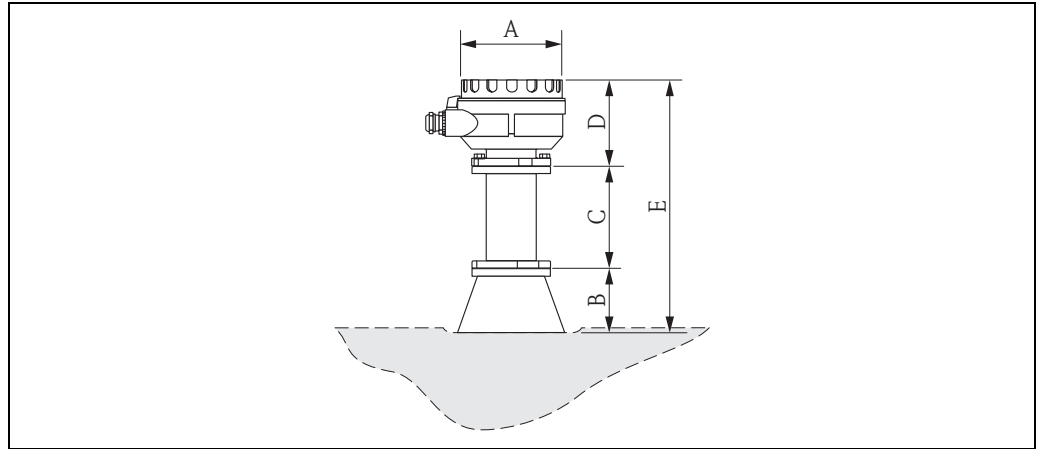

a0002517

*Dimensions in SI and US units*

A		B		C		D		E	
[mm]	[in]	[mm]	[in]	[mm]	[in]	[mm]	[in]	[mm]	[in]
129	5.08	80	3.15	110	4.33	102	4.02	292	11.5

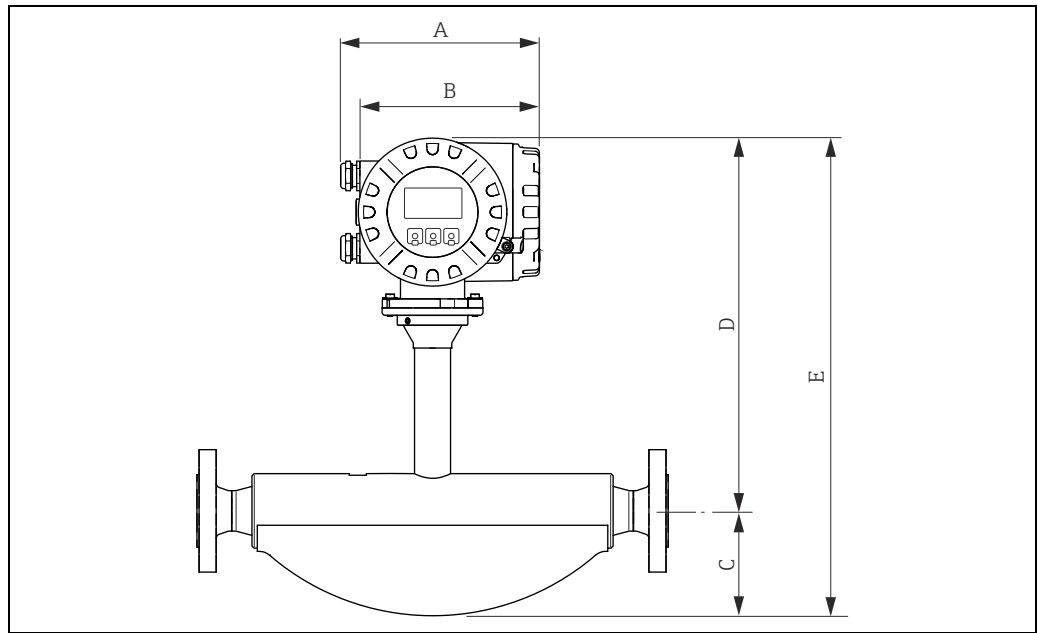
**High-temperature version (compact)**

a0002518

*Dimensions in SI units*

DN	A	B	C	D	E
25	187	168	100	350	450
50	187	168	141	365	506
80	187	168	200	385	585

All dimensions in [mm]

*Dimensions in US units*

DN	A	B	C	D	E
1"	7.36	6.61	3.94	13.78	17.72
2"	7.36	6.61	5.55	14.37	19.92
3"	7.36	6.61	7.87	15.16	23.03

All dimensions in [in]

**High-temperature version (remote)**

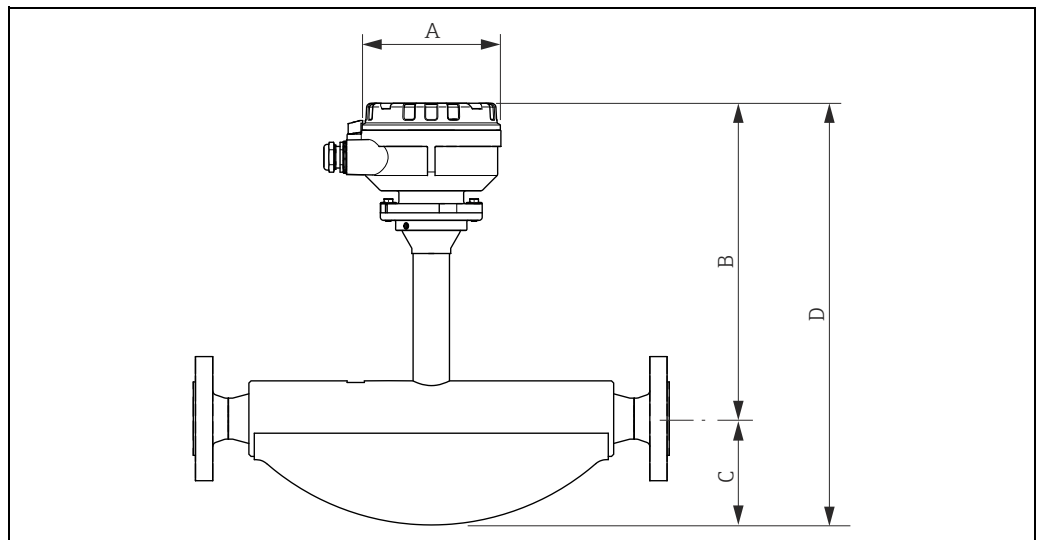

*Dimensions in SI units*

DN	A	B	C	D
25	129	292	105	397
50	129	307	141	448
80	129	327	200	527

All dimensions in [mm]

*Dimensions in US units*

DN	A	B	C	D
1"	5.08	11.50	4.13	15.63
2"	5.08	12.09	5.55	17.64
3"	5.08	12.87	7.87	20.75

All dimensions in [in]

## Process connections in SI units

Flange connections EN (DIN), ASME B16.5, JIS

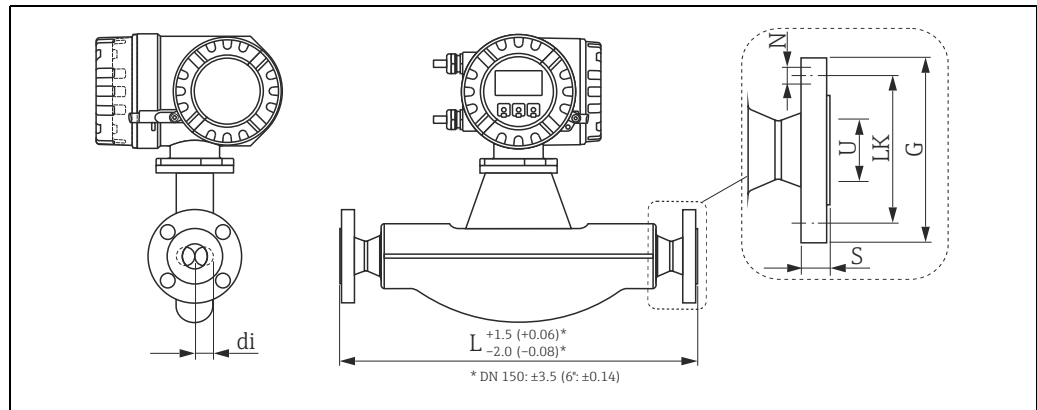

A0002501

Dimension unit in mm (in)

Flange connections EN (DIN)

Flange according to EN 1092-1 (DIN 2501 / DIN 2512N <sup>1)</sup> ) / PN 16: 1.4404 (F316/F316L)							
Surface roughness (flange): EN 1092-1 Form B1 (DIN 2526 Form C), Ra 3.2 to 12.5 µm							
DN	G	L	N	S	LK	U	di
100	220	1127/1400 <sup>2)</sup>	8 × Ø18	20	180	107.1	51.20
150	285	1330/1700 <sup>2)</sup>	8 × Ø22	22	240	159.3	68.90
250 <sup>3)</sup>	405	1775	12 × Ø26	26	355	260.4	102.26

<sup>1)</sup> Flange with groove according to EN 1092-1 Form D (DIN 2512N) available

<sup>2)</sup> Installation length in accordance with NAMUR recommendation NE 132 optionally available (order code for "Process connection", option D1N or D5N (with groove))

<sup>3)</sup> Not available in Alloy

All dimensions in [mm]

Flange according to EN 1092-1 (DIN 2501 / DIN 2512N ) extension-reduction / PN 16: 1.4404 (F316/F316L)							
Only for nominal diameter DN 250 (on request)							
Surface roughness (flange): Ra 0.8 to 3.2 µm							
DN	G	L	N	S	LK	U	di
150	285	1980	8 × Ø22	22	240	159.3	102.26
200	340	1940	12 × Ø22	24	295	207.3	102.26
300	460	1940	12 × Ø26	28	410	309.7	102.26

All dimensions in [mm]

Flange according to EN 1092-1 (DIN 2501 / DIN 2512N <sup>1)</sup> ) / PN 40: 1.4404 (F316/F316L), Alloy C22							
Surface roughness (flange): EN 1092-1 Form B1 (DIN 2526 Form C), Ra 3.2 to 12.5 µm							
DN	G	L	N	S	LK	U	di
8 <sup>2)</sup>	95	370/510 <sup>3)</sup>	4 × Ø14	16	65	17.3	5.35
15	95	404/510 <sup>3)</sup>	4 × Ø14	16	65	17.3	8.30
25	115	440/600 <sup>3)</sup>	4 × Ø14	18	85	28.5	12.00
40	150	550	4 × Ø18	18	110	43.1	17.60



<b>Flange according to EN 1092-1 (DIN 2501 / DIN 2512N<sup>1)</sup>) / PN 40: 1.4404 (F316/F316L), Alloy C22</b>							
<b>Surface roughness (flange): EN 1092-1 Form B1 (DIN 2526 Form C), Ra 3.2 to 12.5 µm</b>							
DN	G	L	N	S	LK	U	di
50	165	715/715 <sup>3)</sup>	4 × Ø18	20	125	54.5	26.00
80	200	840/915 <sup>3)</sup>	8 × Ø18	24	160	82.5	40.50
100	235	1127	8 × Ø22	24	190	107.1	51.20
150	300	1370	8 × Ø26	28	250	159.3	68.90
250 <sup>4)</sup>	450	1845	12 × Ø33	38	385	258.8	102.26

<sup>1)</sup> Flange with groove according to EN 1092-1 Form D (DIN 2512N) available

<sup>2)</sup> DN 8 standard with DN 15 flange

<sup>3)</sup> Installation length in accordance with NAMUR recommendation NE 132 optionally available (order code for "Process connection", option D2N or D6N (with groove))

<sup>4)</sup> Not available in Alloy

All dimensions in [mm]

<b>Flange according to EN 1092-1 (DIN 2501) / PN 40 (with DN 25-Flanges): 1.4404 (F316/F316L)</b>							
<b>Surface roughness (flange): EN 1092-1 Form B1 (DIN 2526 Form C), Ra 3.2 to 12.5 µm</b>							
DN	G	L	N	S	LK	U	di
8	115	440	4 × Ø14	18	85	28.5	5.35
15	115	440	4 × Ø14	18	85	28.5	8.30

All dimensions in [mm]

<b>Flange according to EN 1092-1 (DIN 2501 / DIN 2512N ) extension-reduction / PN 40: 1.4404 (F316/F316L)</b>							
<b>Only for nominal diameter DN 250 (on request)</b>							
<b>Surface roughness (flange): Ra 0.8 to 3.2 µm</b>							
DN	G	L	N	S	LK	U	di
150	300	1980	8 × Ø26	28	250	159.3	102.26
200	375	1940	12 × Ø30	34	320	206.5	102.26
300	515	1940	16 × Ø33	42	450	307.9	102.26

All dimensions in [mm]

<b>Flange according to EN 1092-1 (DIN 2501 / DIN 2512N<sup>1)</sup>) / PN 63: 1.4404 (F316/F316L), Alloy C22</b>							
<b>Surface roughness (flange): EN 1092-1 Form B2 (DIN 2526 Form E), Ra 0.8 to 3.2 µm</b>							
DN	G	L	N	S	LK	U	di
50	180	724	4 × Ø22	26	135	54.5	26.00
80	215	875	8 × Ø22	28	170	81.7	40.50
100	250	1127	8 × Ø26	30	200	106.3	51.20
150	345	1410	8 × Ø33	36	280	157.1	68.90
250 <sup>2)</sup>	470	1885	12 × Ø36	46	400	255.4	102.26

<sup>1)</sup> Flange with groove according to EN 1092-1 Form D (DIN 2512N) available

<sup>2)</sup> Not available in Alloy

All dimensions in [mm]

<b>Flange EN 1092-1 (DIN 2501 / DIN 2512N <sup>1)</sup>) / PN 100: 1.4404 (F316/F316L), Alloy C22</b>							
<b>Surface roughness (flange): EN 1092-1 Form B2 (DIN 2526 Form E), Ra 0.8 to 3.2 µm</b>							
<b>DN</b>	<b>G</b>	<b>L</b>	<b>N</b>	<b>S</b>	<b>LK</b>	<b>U</b>	<b>di</b>
8 <sup>2)</sup>	105	400	4 × Ø14	20	75	17.3	5.35
15	105	420	4 × Ø14	20	75	17.3	8.30
25	140	470	4 × Ø18	24	100	28.5	12.00
40	170	590	4 × Ø22	26	125	42.5	17.60
50	195	740	4 × Ø26	28	145	53.9	26.00
80	230	885	8 × Ø26	32	180	80.9	40.50
100	265	1127	8 × Ø30	36	210	104.3	51.20
150	355	1450	12 × Ø33	44	290	154.0	68.90

<sup>1)</sup> Flange with groove according to EN 1092-1 Form D (DIN 2512N) available

<sup>2)</sup> DN 8 standard with DN 15 flange

All dimensions in [mm]

#### Flange connections ASME B16.5

<b>Flange according to ASME B16.5 / Cl 150: 1.4404 (F316/F316L), Alloy C22</b>							
<b>Surface roughness (flange): Ra 3.2 to 6.3 µm</b>							
<b>DN</b>	<b>G</b>	<b>L</b>	<b>N</b>	<b>S</b>	<b>LK</b>	<b>U</b>	<b>di</b>
8 <sup>2)</sup>	90	370	4 × Ø15.7	11.2	60.3	15.7	5.35
15	90	404	4 × Ø15.7	11.2	60.4	15.7	8.30
25	110	440	4 × Ø15.7	14.2	79.4	26.7	12.00
40	125	550	4 × Ø15.7	17.5	98.4	40.9	17.60
50	150	715	4 × Ø19.1	19.1	120.7	52.6	26.00
80	190	840	4 × Ø19.1	23.9	152.4	78.0	40.50
100	230	1127	8 × Ø19.1	23.9	190.5	102.4	51.20
150	280	1398	8 × Ø22.4	25.4	241.3	154.2	68.90
250 <sup>1)</sup>	405	1832	12 × Ø25.4	30.2	362	254.5	102.26

<sup>1)</sup> Not available in Alloy

<sup>2)</sup> DN 8 standard with DN 15 flange

All dimensions in [mm]

<b>Flange according to ASME B16.5 extension-reduction / Cl 150: 1.4404 (F316/F316L)</b>							
<b>Only for nominal diameter DN 250 / 10" (auf Anfrage)</b>							
<b>Surface roughness (flange): Ra 3.2 to 6.3 µm</b>							
<b>DN</b>	<b>G</b>	<b>L</b>	<b>N</b>	<b>S</b>	<b>LK</b>	<b>U</b>	<b>di</b>
150	279.4	1980	8 × Ø22.4	25.4	241.3	154.2	102.26
200	342.9	1940	8 × Ø22.4	28.4	298.5	202.7	102.26
300	482.6	1940	12 × Ø25.4	31.8	431.8	304.80	102.26

All dimensions in [mm]

<b>Flange according to ASME B16.5 / CI 300: 1.4404 (F316/F316L), Alloy C22</b>							
<b>Surface roughness (flange): Ra 3.2 to 6.3 µm</b>							
<b>DN</b>	<b>G</b>	<b>L</b>	<b>N</b>	<b>S</b>	<b>LK</b>	<b>U</b>	<b>di</b>
8 <sup>2)</sup>	95	370	4 × Ø15.7	14.2	66.7	15.7	5.35
15	95	404	4 × Ø15.7	14.2	66.7	15.7	8.30
25	125	440	4 × Ø19.0	17.5	88.9	26.7	12.00
40	155	550	4 × Ø22.3	20.6	114.3	40.9	17.60
50	165	715	8 × Ø19.0	22.3	127	52.6	26.00
80	210	840	8 × Ø22.3	28.4	168.3	78.0	40.50
100	255	1127	8 × Ø22.3	31.7	200	102.4	51.20
150	320	1417	12 × Ø22.3	36.5	269.9	154.2	68.90
250 <sup>1)</sup>	445	1863	16 × Ø28.4	47.4	387.4	254.5	102.26

<sup>1)</sup> Not available in Alloy

<sup>2)</sup> DN 8 standard with DN 15 flange

All dimensions in [mm]

<b>Flange according to ASME B16.5 extension-reduction / CI 300: 1.4404 (F316/F316L)</b>							
<b>Only for nominal diameter DN 250 /10" (auf Anfrage)</b>							
<b>Surface roughness (flange): Ra 3.2 to 6.3 µm</b>							
<b>DN</b>	<b>G</b>	<b>L</b>	<b>N</b>	<b>S</b>	<b>LK</b>	<b>U</b>	<b>di</b>
150	317.5	1980	12 × Ø22.4	36.5	269.7	154.2	102.26
200	381.0	1940	12 × Ø25.4	41.1	330.2	202.7	102.26
300	520.7	1940	16 × Ø31.7	50.8	450.8	304.80	102.26

All dimensions in [mm]

<b>Flange according to ASME B16.5 / CI 600: 1.4404 (F316/F316L), Alloy C22</b>							
<b>Surface roughness (flange): Ra 3.2 to 6.3 µm</b>							
<b>DN</b>	<b>G</b>	<b>L</b>	<b>N</b>	<b>S</b>	<b>LK</b>	<b>U</b>	<b>di</b>
8 <sup>2)</sup>	95	400	4 × Ø15.7	20.6	66.7	13.9	5.35
15	95	420	4 × Ø15.7	20.6	66.7	13.9	8.30
25	125	490	4 × Ø19.1	23.9	88.9	24.3	12.00
40	155	600	4 × Ø22.4	28.7	114.3	38.1	17.60
50	165	742	8 × Ø19.1	31.8	127	49.2	26.00
80	210	900	8 × Ø22.4	38.2	168.3	73.7	40.50
100	275	1157	8 × Ø25.4	48.4	215.9	97.3	51.20
150	355	1467	12 × Ø28.4	47.8	292.1	154.2	68.90
250 <sup>1)</sup>	510	1946	16 × Ø35.1	69.9	431.8	254.5	102.26

<sup>1)</sup> Not available in Alloy

<sup>2)</sup> DN 8 standard with DN 15 flange

All dimensions in [mm]

<b>Flange according to ASME B16.5 extension-reduction / CI 600: 1.4404 (F316/F316L)</b>							
<b>Only for nominal diameter DN 250 /10" (auf Anfrage)</b>							
<b>Surface roughness (flange): Ra 3.2 to 6.3 µm</b>							
<b>DN</b>	<b>G</b>	<b>L</b>	<b>N</b>	<b>S</b>	<b>LK</b>	<b>U</b>	<b>di</b>
150	355.6	1980	12 × Ø28.4	54.2	292.1	154.2	102.26
200	419.1	1940	12 × Ø31.8	62.0	349.3	202.7	102.26

All dimensions in [mm]

*Flange connections JIS B2220*

<b>Flange JIS B2220 / 10K: 1.4404 (F316/F316L), Alloy C22</b>							
<b>Surface roughness (flange): Ra 3.2 to 6.3 µm</b>							
<b>DN</b>	<b>G</b>	<b>L</b>	<b>N</b>	<b>S</b>	<b>LK</b>	<b>U</b>	<b>di</b>
50	155	715	4 × Ø19	16	120	50	26.00
80	185	832	8 × Ø19	18	150	80	40.50
100	210	1127	8 × Ø19	18	175	100	51.20
150	280	1354	8 × Ø23	22	240	150	68.90
250 <sup>1)</sup>	400	1775	12 × Ø25	24	355	250	102.26

<sup>1)</sup> Not available in Alloy  
All dimensions in [mm]

<b>Flange JIS B2220 extension-reduction / 10K: 1.4404 (F316/F316L)</b>							
<b>Only for nominal diameter DN 250 (on request)</b>							
<b>Surface roughness (flange): Ra 1.6 to 3.2 µm</b>							
<b>DN</b>	<b>G</b>	<b>L</b>	<b>N</b>	<b>S</b>	<b>LK</b>	<b>U</b>	<b>di</b>
150	280	1980	8 × Ø23	22	240	150	102.26
200	330	1940	12 × Ø23	22	290	200	102.26
300	445	1940	16 × Ø25	24	400	300	102.26

All dimensions in [mm]

<b>Flange JIS B2220 / 20K: 1.4404 (F316/F316L), Alloy C22</b>							
<b>Surface roughness (flange): Ra 1.6 to 3.2 µm</b>							
<b>DN</b>	<b>G</b>	<b>L</b>	<b>N</b>	<b>S</b>	<b>LK</b>	<b>U</b>	<b>di</b>
8 <sup>2)</sup>	95	370	4 × Ø15	14	70	15	5.35
15	95	404	4 × Ø15	14	70	15	8.30
25	125	440	4 × Ø19	16	90	25	12.00
40	140	550	4 × Ø19	18	105	40	17.60
50	155	715	8 × Ø19	18	120	50	26.00
80	200	832	8 × Ø23	22	160	80	40.50
100	225	1128	8 × Ø23	24	185	100	51.20
150	305	1386	12 × Ø25	28	260	150	68.90
250 <sup>1)</sup>	430	1850	12 × Ø27	34	380	250	102.26

<sup>1)</sup> Not available in Alloy

<sup>2)</sup> DN 8 standard with DN 15 flange

All dimensions in [mm]

<b>Flange JIS B2220 extension-reduction / 20K: 1.4404 (F316/F316L)</b>							
<b>Only for nominal diameter DN 250 (on request)</b>							
<b>Surface roughness (flange): Ra 1.6 to 3.2 µm</b>							
<b>DN</b>	<b>G</b>	<b>L</b>	<b>N</b>	<b>S</b>	<b>LK</b>	<b>U</b>	<b>di</b>
150	305	1980	12 × Ø25	28	260	150	102.26
200	350	1940	12 × Ø25	30	305	200	102.26
300	480	1940	16 × Ø27	36	430	300	102.26

All dimensions in [mm]

<b>Flange JIS B2220 / 40K: 1.4404 (F316/F316L), Alloy C22</b>							
<b>Surface roughness (flange): Ra 1.6 to 3.2 µm</b>							
<b>DN</b>	<b>G</b>	<b>L</b>	<b>N</b>	<b>S</b>	<b>LK</b>	<b>U</b>	<b>di</b>
8 <sup>1)</sup>	115	400	4 × Ø19	20	80	15	5.35
15	115	425	4 × Ø19	20	80	15	8.30
25	130	485	4 × Ø19	22	95	25	12.00
40	160	600	4 × Ø23	24	120	38	17.60
50	165	760	8 × Ø19	26	130	50	26.00
80	210	890	8 × Ø23	32	170	75	40.50
100	250	1167	8 × Ø25	36	205	100	51.20
150	355	1498	12 × Ø33	44	295	150	68.90

All dimensions in [mm]

<sup>1)</sup> DN 8 standard with DN 15 flange

<b>Flange JIS B2220 / 63K: 1.4404 (F316/F316L), Alloy C22</b>							
<b>Surface roughness (flange): Ra 1.6 to 3.2 µm</b>							
<b>DN</b>	<b>G</b>	<b>L</b>	<b>N</b>	<b>S</b>	<b>LK</b>	<b>U</b>	<b>di</b>
8 <sup>1)</sup>	120	420	4 × Ø19	23	85	12	5.35
15	120	440	4 × Ø19	23	85	12	8.30

Flange JIS B2220 / 63K: 1.4404 (F316/F316L), Alloy C22							
Surface roughness (flange): Ra 1.6 to 3.2 $\mu\text{m}$							
DN	G	L	N	S	LK	U	di
25	140	494	4 × $\varnothing$ 23	27	100	22	12.00
40	175	620	4 × $\varnothing$ 25	32	130	35	17.60
50	185	775	8 × $\varnothing$ 23	34	145	48	26.00
80	230	915	8 × $\varnothing$ 25	40	185	73	40.50
100	270	1167	8 × $\varnothing$ 27	44	220	98	51.20
150	365	1528	12 × $\varnothing$ 33	54	305	146	68.90

All dimensions in [mm]

<sup>1)</sup> DN 8 standard with DN 15 flange

Lap joint flange EN (DIN), ASME B16.5, JIS

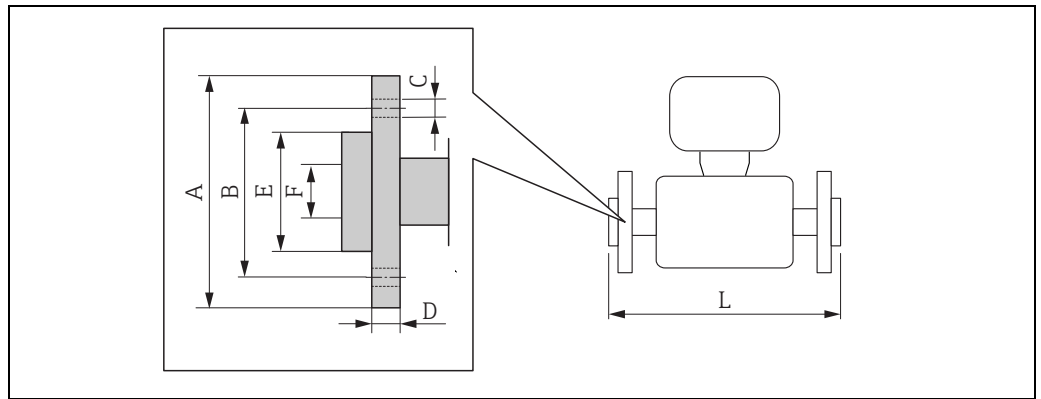

Measuring unit: mm (in)

Lap joint flange EN (DIN)

Lap joint flange according to EN 1092-1 (DIN 2501/DIN 2512N) PN 40: 1.4301 (F304) (order code "Process connection", option DAC); wetted parts: Alloy C22 Surface roughness (flange): Ra 3.2 to 12.5 µm								
DN	A	B	C	D	E	F	L	L <sub>diff</sub> <sup>1)</sup>
8 <sup>2)</sup>	95	65	4 × Ø14	14.5	45	17.3	370	0
15	95	65	4 × Ø14	14.5	45	17.3	404	0
25	115	85	4 × Ø14	16.5	68	28.5	444	+4
40	150	110	4 × Ø18	21	88	41.3	560	+10
50	165	125	4 × Ø18	23	102	54.5	719	+4
80	200	160	8 × Ø18	29	138	82.5	848	+8
100	235	190	8 × Ø22	34	162	107.1	1131	+4

<sup>1)</sup> Difference to the installation length of the welding neck flange (order code "Process connection", option D2C)

<sup>2)</sup> DN 8 standard with DN 15 flange

All dimensions in [mm]

Lap joint flange ASME B16.6

Lap joint flange according to ASME B16.5 CI 150: 1.4301 (F304) (order code "Process connection", option ADC); wetted parts: Alloy C22 Surface roughness (flange): Ra 3.2 to 12.5 µm								
DN	A	B	C	D	E	F	L	L <sub>diff</sub> <sup>1)</sup>
8 <sup>2)</sup>	90	60.3	4 × Ø15.7	15.0	35.1	15.7	370	0
15	90	60.3	4 × Ø15.7	15.0	35.1	15.7	404	0
25	110	79.4	4 × Ø15.7	16.0	50.8	26.7	440	0
40	125	98.4	4 × Ø15.7	15.9	73.2	40.9	550	0
50	150	120.7	4 × Ø19.1	19.0	91.9	52.6	715	0
80	190	152.4	8 × Ø19.1	22.3	127.0	78.0	840	0
100	230	190.5	8 × Ø19.1	26.0	157.2	102.4	1127	0

<sup>1)</sup> Difference to the installation length of the welding neck flange (order code "Process connection", option AAC)

<sup>2)</sup> DN 8 standard with DN 15 flange

All dimensions in [mm]

Lap joint flange according to ASME B16.5 Cl 300: 1.4301 (F304) (order code "Process connection", option AEC); wetted parts: Alloy C22 Surface roughness (flange): Ra 3.2 to 12.5 µm								
DN	A	B	C	D	E	F	L	L <sub>diff</sub> <sup>1)</sup>
8 <sup>2)</sup>	95	66.7	4 × Ø15.7	16.5	35.1	15.7	376	+6
15	95	66.7	4 × Ø15.7	16.5	35.1	15.7	406	+2
25	125	88.9	4 × Ø19.1	21.0	50.8	26.7	450	+10
40	155	114.3	4 × Ø22.3	23.0	73.2	40.9	564	+14
50	165	127	8 × Ø19.1	25.5	91.9	52.6	717	+2
80	210	168.3	8 × Ø22.3	31.0	127.0	78.0	852.6	+12.6
100	255	200	8 × Ø22.3	32.0	157.2	102.4	1139	+12

<sup>1)</sup> Difference to the installation length of the welding neck flange (order code "Process connection", option ABC)

<sup>2)</sup> DN 8 standard with DN 15 flange

All dimensions in [mm]

Lap joint flange according to ASME B16.5 Cl 600: 1.4301 (F304) (order code "Process connection", option AFC); wetted parts: Alloy C22 Surface roughness (flange): Ra 3.2 to 12.5 µm								
DN	A	B	C	D	E	F	L	L <sub>diff</sub> <sup>1)</sup>
8 <sup>2)</sup>	95	66.7	4 × Ø15.7	17.0	35.1	13.9	400	0
15	95	66.7	4 × Ø15.7	17.0	35.1	13.9	420	0
25	125	88.9	4 × Ø19.1	21.5	50.8	24.3	490	0
40	155	114.3	4 × Ø22.3	25.0	73.2	38.1	600	0
50	165	127	4 × Ø19.1	28.0	91.9	49.2	742	0
80	210	168.3	8 × Ø22.3	35.0	127.0	73.7	900	0
100	275	215.9	8 × Ø25.4	44.0	157.2	97.3	1167	+10

<sup>1)</sup> Difference to the installation length of the welding neck flange (order code "Process connection", option ACC)

<sup>2)</sup> DN 8 standard with DN 15 flange

All dimensions in [mm]

#### Lap joint flange JIS

Lap joint flange JIS B2220 20K: 1.4301 (F304) (order code "Process connection", option NIC); wetted parts: Alloy C22 Surface roughness (flange): Ra 3.2 to 12.5 µm								
DN	A	B	C	D	E	F	L	L <sub>diff</sub> <sup>1)</sup>
8 <sup>2)</sup>	95	70	4 × Ø15	14.0	51	15	370	0
15	95	70	4 × Ø15	14.0	51	15	404	0
25	125	90	4 × Ø19	18.5	67	25	440	0
40	140	105	4 × Ø19	18.5	81	40	550	0
50	155	120	8 × Ø19	23.0	96	50	715	0
80	200	160	8 × Ø23	29.0	132	80	844	+12
100	225	185	8 × Ø23	29.0	160	100	1127	+0

<sup>1)</sup> Difference to the installation length of the welding neck flange (order code "Process connection", option NEC)

<sup>2)</sup> DN 8 standard with DN 15 flange

All dimensions in [mm]



Tri-Clamp

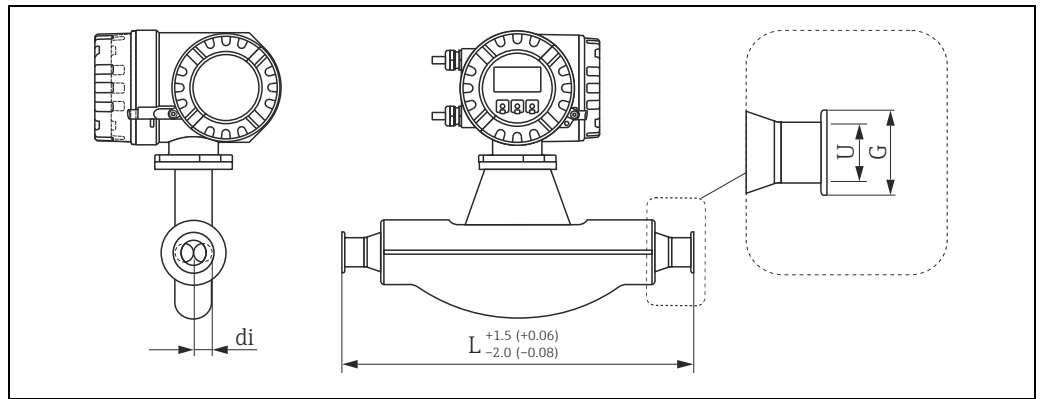

Dimension unit in mm (in)

Tri-Clamp: 1.4404 (316/316L)					
DN	Clamp	G	L	U	di
8	1"	50.4	367	22.1	5.35
15	1"	50.4	398	22.1	8.30
25	1"	50.4	434	22.1	12.00
40	1½"	50.4	560	34.8	17.60
50	2"	63.9	720	47.5	26.00
80	3"	90.9	900	72.9	40.50
100	4"	118.9	1127	97.4	51.20

3A version also available (Ra ≤ 0.8 µm/150 grit, option: Ra ≤ 0.4 µm/240 grit)  
All dimensions in [mm]

½"-Tri-Clamp: 1.4404 (316/316L)					
DN	Clamp	G	L	U	di
8	½"	25.0	367	9.5	5.35
15	½"	25.0	398	9.5	8.30

3A version also available (Ra ≤ 0.8 µm/150 grit, option: Ra ≤ 0.4 µm/240 grit)  
All dimensions in [mm]

## DIN 11851 (threaded hygienic connection)

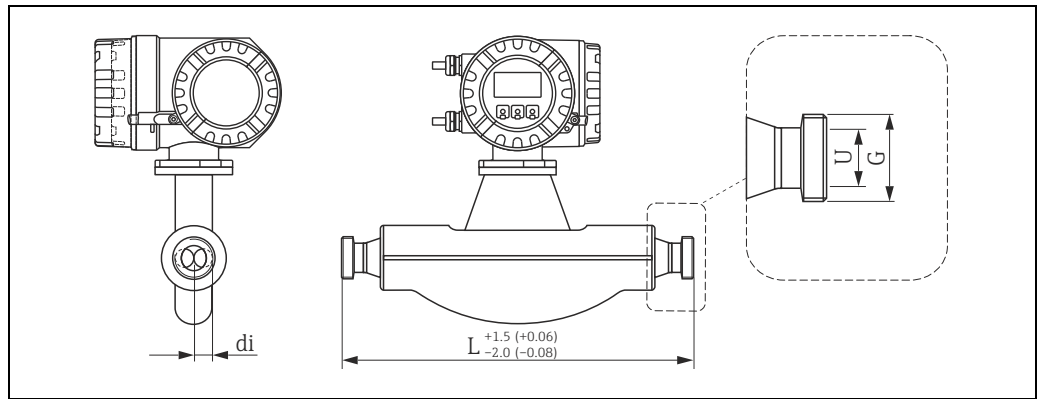

Dimension unit in mm (in)

Threaded hygienic connection DIN 11851: 1.4404 (316/316L)				
DN	G	L	U	di
8	Rd 34 × 1/8"	367	16	5.35
15	Rd 34 × 1/8"	398	16	8.30
25	Rd 52 × 1/6"	434	26	12.00
40	Rd 65 × 1/6"	560	38	17.60
50	Rd 78 × 1/6"	720	50	26.00
80	Rd 110 × 1/4"	900	81	40.50
100	Rd 130 × 1/4"	1127	100	51.20

3A version also available (Ra ≤ 0.8 μm/150 grit)  
All dimensions in [mm]

DIN 11864-1 Form A (aseptic threaded connection)

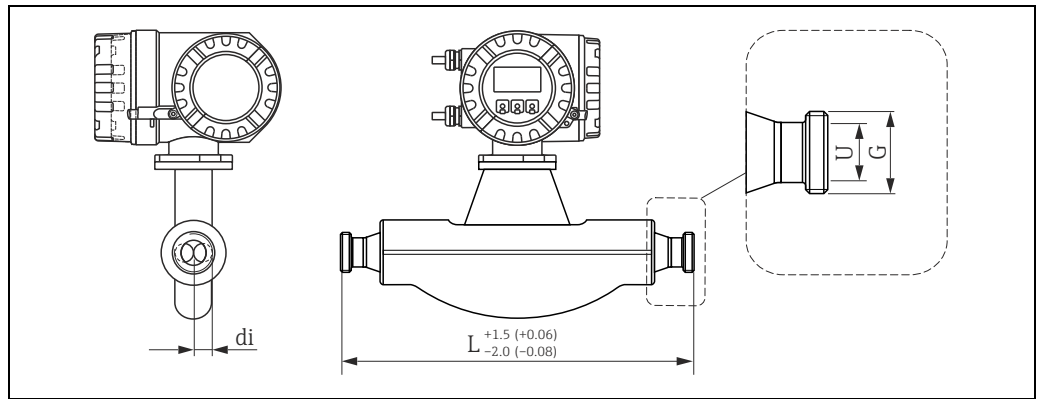

Dimension unit in mm (in)

Aseptic threaded connection DIN 11864-1 Form A: 1.4404 (316/316L)				
DN	G	L	U	di
8	Rd 28 × 1/8"	367	10	5.35
15	Rd 34 × 1/8"	398	16	8.30
25	Rd 52 × 1/6"	434	26	12.00
40	Rd 65 × 1/6"	560	38	17.60
50	Rd 78 × 1/6"	720	50	26.00
80	Rd 110 × 1/4"	900	81	40.50
100	Rd 130 × 1/4"	1127	100	51.20

3A version also available (Ra ≤ 0.8 µm/150 grit)  
All dimensions in [mm]

## DIN 11864-2 Form A (aseptic flat flange with groove)

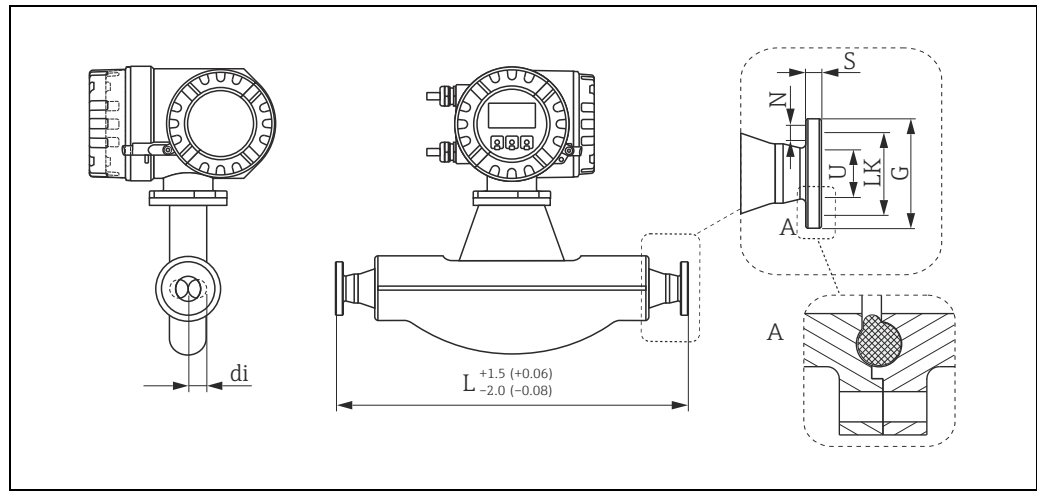

Detail A: The flange has the smaller groove for the O-ring on the sensor side. When mounting the sensor the corresponding flange must have accordingly a larger groove.

Dimension unit in mm (in)

DIN 11864-2 Form A (aseptic flat flange with groove): 1.4404 (316/316L)							
DN	G	L	N	S	LK	U	di
8	54	387	4 × Ø9	10	37	10	5.35
15	59	418	4 × Ø9	10	42	16	8.30
25	70	454	4 × Ø9	10	53	26	12.00
40	82	560	4 × Ø9	10	65	38	17.60
50	94	720	4 × Ø9	10	77	50	26.00
80	133	900	8 × Ø11	12	112	81	40.50
100	159	1127	8 × Ø11	14	137	100	51.20

3A version also available (Ra ≤ 0.8 µm/150 grit, option: Ra ≤ 0.4 µm/240 grit)

All dimensions in [mm]

ISO 2853 (threaded hygienic connection)

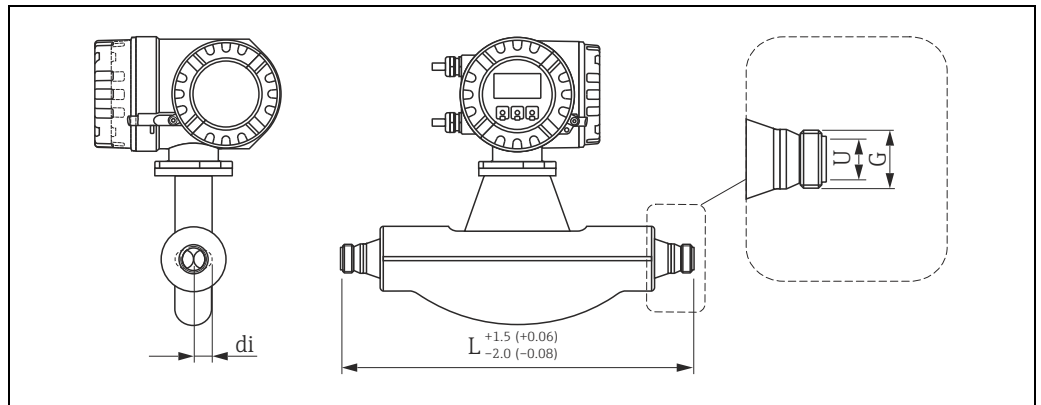

Dimension unit in mm (in)

Threaded hygienic connection ISO 2853: 1.4404 (316/316L)				
DN	G <sup>1)</sup>	L	U	di
8	37.13	367	22.6	5.35
15	37.13	398	22.6	8.30
25	37.13	434	22.6	12.00
40	52.68	560	35.6	17.60
50	64.16	720	48.6	26.00
80	91.19	900	72.9	40.50
100	118.21	1127	97.6	51.20

<sup>1)</sup> Max. thread diameter to ISO 2853 Annex A  
 3A version also available (Ra ≤ 0.8 µm/150 grit, option: Ra ≤ 0.4 µm/240 grit)  
 All dimensions in [mm]

## SMS 1145 (threaded hygienic connection)

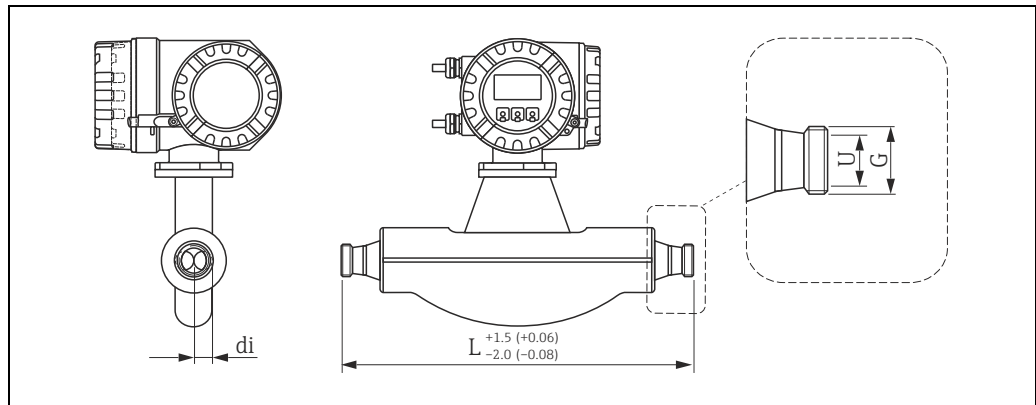

A0022588

Dimension unit in mm (in)

Threaded hygienic connections SMS 1145: 1.4404 (316/316L)				
DN	G	L	U	di
8	Rd 40 x 1/6"	367	22.6	5.35
15	Rd 40 x 1/6"	398	22.6	8.30
25	Rd 40 x 1/6"	434	22.6	12.00
40	Rd 60 x 1/6"	560	35.6	17.60
50	Rd 70 x 1/6"	720	48.6	26.00
80	Rd 98 x 1/6"	900	72.9	40.50
100	Rd 132 x 1/6"	1127	97.6	51.20

3A version also available ( $Ra \leq 0.8 \mu\text{m}/150$  grit, option:  $Ra \leq 0.4 \mu\text{m}/240$  grit)  
 All dimensions in [mm]

VCO connections

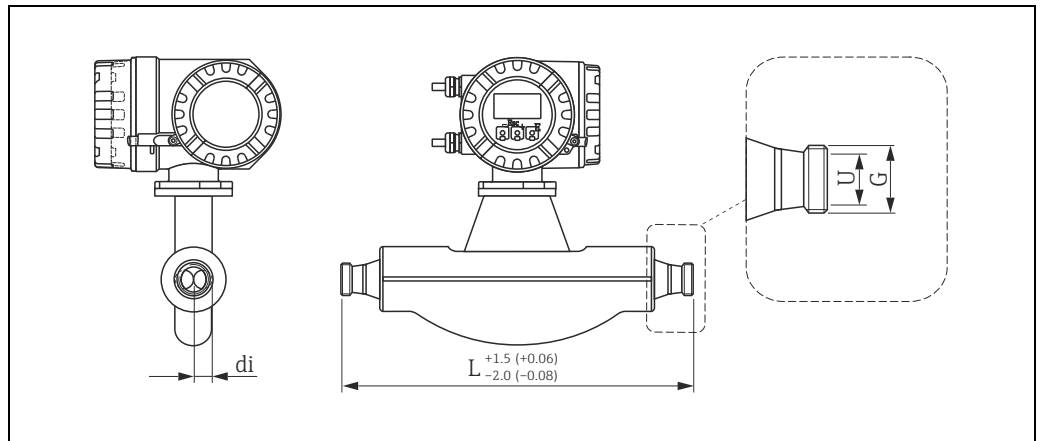

A002257

Dimension unit in mm (in)

8-VCO-4 (½"): 1.4404 (316/316L)				
DN	G	L	U	di
8	AF 1"	390	10.2	5.35

All dimensions in [mm]

12-VCO-4 (¾"): 1.4404 (316/316L)				
DN	G	L	U	di
15	AF 1½"	430	15.7	8.30

All dimensions in [mm]

## Process connections in US units

Flange connections ASME B16.5

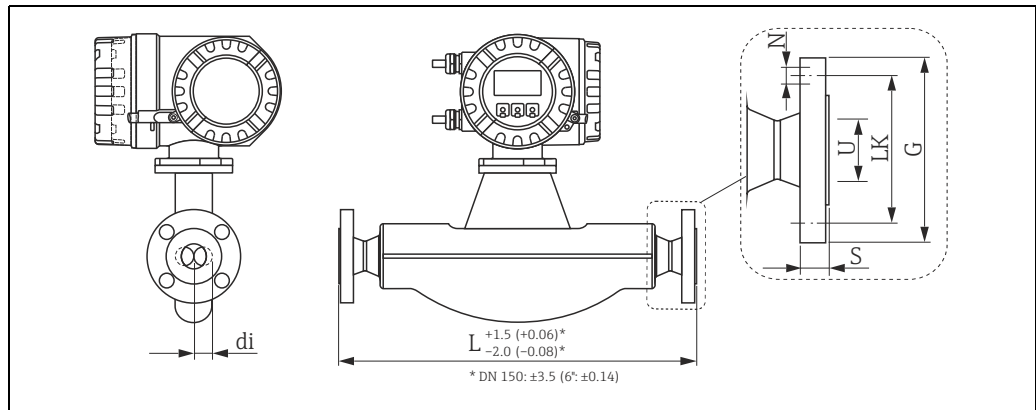

A0002501

Dimension unit in mm (in)

Flange according to ASME B16.5 / Cl 150: 1.4404 (F316/F316L), Alloy C22							
Surface roughness (flange): Ra 3.2 to 6.3 $\mu\text{m}$							
DN	G	L	N	S	LK	U	di
$\frac{3}{8}$ " <sup>2)</sup>	3.54	14.57	4 × $\varnothing 0.62$	0.44	2.37	0.62	0.21
$\frac{1}{2}$ "	3.54	15.91	4 × $\varnothing 0.62$	0.44	2.37	0.62	0.33
1"	4.33	17.32	4 × $\varnothing 0.62$	0.56	3.13	1.05	0.47
1½"	4.92	21.65	4 × $\varnothing 0.62$	0.69	3.87	1.61	0.69
2"	5.91	28.15	4 × $\varnothing 0.75$	0.75	4.75	2.07	1.02
3"	7.48	33.07	4 × $\varnothing 0.75$	0.94	6	3.07	1.59
4"	9.06	44.37	8 × $\varnothing 0.75$	0.94	7.5	4.03	2.01
6"	11.02	55.04	8 × $\varnothing 0.88$	1	9.5	6.07	2.71
10" <sup>1)</sup>	15.94	72.13	12 × $\varnothing 1.0$	1.19	14.25	10.02	4.03

<sup>1)</sup> Not available in Alloy

<sup>2)</sup> DN  $\frac{3}{8}$ " standard with DN  $\frac{1}{2}$ " flange

All dimensions in [in]

Flange according to ASME B16.5 extension-reduction / Cl 150: 1.4404 (F316/F316L)							
Only for nominal diameter DN 250 / 10" (on request)							
Surface roughness (flange): Ra 3.2 to 6.3 $\mu\text{m}$							
DN	G	L	N	S	LK	U	di
6"	11	77.95	8 × $\varnothing 22.4$	1	9.5	6.07	4.03
8"	13.5	76.38	8 × $\varnothing 22.4$	1.12	11.75	7.98	4.03
12"	19	76.38	12 × $\varnothing 25.4$	1.25	17	12.00	4.03

All dimensions in [in]



<b>Flange according to ASME B16.5 / CI 300: 1.4404 (F316/F316L), Alloy C22</b>							
<b>Surface roughness (flange): Ra 3.2 to 6.3 µm</b>							
DN	G	L	N	S	LK	U	di
3/8" <sup>2)</sup>	3.74	14.57	4 × Ø0.62	0.56	2.63	0.62	0.21
1/2"	3.74	15.91	4 × Ø0.62	0.56	2.63	0.62	0.33
1"	4.92	17.32	4 × Ø0.75	0.69	3.5	1.05	0.47
1 1/2"	6.12	21.65	4 × Ø0.88	0.81	4.5	1.61	0.69
2"	6.5	28.15	8 × Ø0.75	0.88	5	2.07	1.02
3"	8.27	33.07	8 × Ø0.88	1.12	6.63	3.07	1.59
4"	10.04	44.37	8 × Ø0.88	1.25	7.87	4.03	2.02
6"	12.6	55.79	12 × Ø0.88	1.44	10.63	6.07	2.71
10" <sup>1)</sup>	17.52	73.35	16 × Ø1.12	1.87	15.25	10.02	4.03

<sup>1)</sup> Not available in Alloy

<sup>2)</sup> DN 3/8" standard with DN 1/2" flange

All dimensions in [in]

<b>Flange according to ASME B16.5 extension-reduction / CI 300: 1.4404 (F316/F316L)</b>							
<b>Only for nominal diameter DN 250 /10" (on request)</b>							
<b>Surface roughness (flange): Ra 3.2 to 6.3 µm</b>							
DN	G	L	N	S	LK	U	di
6"	12.5	78.0	12 × Ø0.88	1.44	10.6	6.07	4.03
8"	15.0	76.4	12 × Ø1.00	1.62	13.0	7.98	4.03
12"	20.5	76.4	16 × Ø1.25	2.00	17.7	12.0	4.03

All dimensions in [in]

<b>Flange according to ASME B16.5 / CI 600: 1.4404 (F316/F316L), Alloy C22</b>							
<b>Surface roughness (flange): Ra 3.2 to 6.3 µm</b>							
DN	G	L	N	S	LK	U	di
3/8" <sup>2)</sup>	3.74	15.75	4 × Ø0.62	0.81	2.63	0.55	0.21
1/2"	3.74	16.54	4 × Ø0.62	0.81	2.63	0.55	0.33
1"	4.92	19.29	4 × Ø0.75	0.94	3.5	0.96	0.47
1 1/2"	6.1	23.62	4 × Ø0.88	1.13	4.5	1.5	0.69
2"	6.5	29.21	8 × Ø0.75	1.25	5	1.94	1.02
3"	8.27	35.43	8 × Ø0.88	1.5	6.63	2.90	1.59
4"	10.83	45.55	8 × Ø1.00	1.91	8.5	3.83	2.02
6"	13.98	57.76	12 × Ø1.12	1.88	11.5	6.07	2.71
10" <sup>1)</sup>	20.08	76.61	16 × Ø1.38	2.75	17	10.02	4.03

<sup>1)</sup> Not available in Alloy

<sup>2)</sup> DN 3/8" standard with DN 1/2" flange

All dimensions in [in]

<b>Flange according to ASME B16.5 extension-reduction / CI 600: 1.4404 (F316/F316L)</b>							
<b>Only for nominal diameter DN 250 /10" (on request)</b>							
<b>Surface roughness (flange): Ra 3.2 to 6.3 µm</b>							
<b>DN</b>	<b>G</b>	<b>L</b>	<b>N</b>	<b>S</b>	<b>LK</b>	<b>U</b>	<b>di</b>
6"	14.0	78.0	12 × Ø1.12	2.13	11.5	6.07	4.03
8"	16.5	76.4	12 × Ø1.25	2.44	13.7	7.98	4.03

All dimensions in [in]

Lap joint flange ASME B16.5

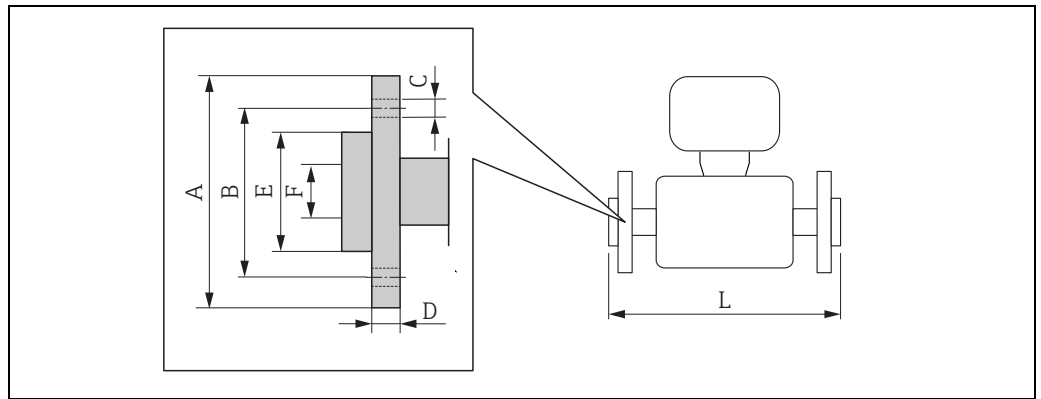

Measuring unit: mm (in)

Lap joint flange according to ASME B16.5 CI 150: 1.4301 (F304) (order code "Process connection", option ADC); wetted parts: Alloy C22 Surface roughness (flange): Ra 3.2 to 12.5 µm								
DN	A	B	C	D	E	F	L	L <sub>diff</sub> <sup>1)</sup>
3/8" <sup>2)</sup>	3.54	2.37	4 × Ø0.62	0.59	1.38	0.62	14.57	0
1/2"	3.54	2.37	4 × Ø0.62	0.59	1.38	0.62	15.91	0
1"	4.33	3.13	4 × Ø0.62	0.63	2	1.05	17.32	0
1 1/2"	4.92	3.87	4 × Ø0.62	0.63	2.88	1.61	21.65	0
2"	5.91	4.75	4 × Ø0.75	0.75	3.62	2.07	28.15	0
3"	7.48	6	8 × Ø0.75	0.88	5	3.07	33.07	0
4"	9.06	7.5	8 × Ø0.75	1.02	6.19	4.03	44.37	0

<sup>1)</sup> Difference to the installation length of the welding neck flange (order code "Process connection", option AAC)  
<sup>2)</sup> DN 3/8" standard with DN 1/2" flange  
 All dimensions in [in]

Lap joint flange according to ASME B16.5 CI 300: 1.4301 (F304) (order code "Process connection", option AEC); wetted parts: Alloy C22 Surface roughness (flange): Ra 3.2 to 12.5 µm								
DN	A	B	C	D	E	F	L	L <sub>diff</sub> <sup>1)</sup>
3/8" <sup>2)</sup>	3.74	2.63	4 × Ø0.62	0.65	1.38	0.62	14.8	+0.23
1/2"	3.74	2.63	4 × Ø0.62	0.65	1.38	0.62	15.98	+0.07
1"	4.92	3.50	4 × Ø0.75	0.83	2	1.05	17.72	+0.40
1 1/2"	6.1	4.50	4 × Ø0.88	0.91	2.88	1.61	22.2	+0.55
2"	6.5	5	4 × Ø0.75	1	3.62	2.07	28.23	+0.08
3"	8.27	6.63	8 × Ø0.88	1.22	5	3.07	33.57	+0.50
4"	10.04	7.87	8 × Ø0.88	1.26	6.19	4.03	44.84	+0.47

<sup>1)</sup> Difference to the installation length of the welding neck flange (order code "Process connection", option ABC)  
<sup>2)</sup> DN 3/8" standard with DN 1/2" flange  
 All dimensions in [in]

Lap joint flange according to ASME B16.5 Cl 600: 1.4301 (F304) (order code "Process connection", option AFC); wetted parts: Alloy C22 Surface roughness (flange): Ra 3.2 to 12.5 µm								
DN	A	B	C	D	E	F	L	L <sub>diff</sub> <sup>1)</sup>
$\frac{3}{8}$ " <sup>2)</sup>	3.74	2.63	4 × Ø0.62	0.67	1.38	0.55	15.75	0
$\frac{1}{2}$ "	3.74	2.63	4 × Ø0.62	0.67	1.38	0.55	16.54	0
1"	4.92	3.5	4 × Ø0.75	0.85	2	0.96	19.29	0
1½"	6.1	4.5	4 × Ø0.88	0.98	2.88	1.50	23.62	0
2"	6.5	5	4 × Ø0.75	1.1	3.62	1.94	29.21	0
3"	8.27	6.63	8 × Ø0.88	1.38	5	2.9	35.43	0
4"	10.83	8.5	8 × Ø1	1.73	6.19	3.83	45.94	+0.39

<sup>1)</sup> Difference to the installation length of the welding neck flange (order code "Process connection", option ACC)

<sup>2)</sup> DN  $\frac{3}{8}$ " standard with DN  $\frac{1}{2}$ " flange

All dimensions in [in]

Tri-Clamp

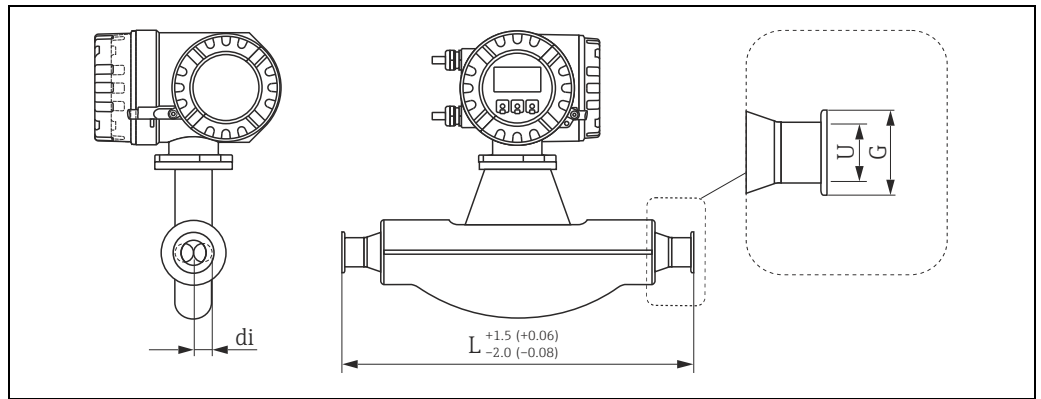

Dimension unit in mm (in)

Tri-Clamp: 1.4404 (316/316L)					
DN	Clamp	G	L	U	di
3/8"	1"	1.98	14.4	0.87	0.21
1/2"	1"	1.98	15.7	0.87	0.33
1"	1"	1.98	17.1	0.87	0.47
1 1/2"	1 1/2"	1.98	22.0	1.37	0.69
2"	2"	2.52	28.3	1.87	1.02
3"	3"	3.58	35.4	2.87	1.59
4"	4"	4.68	44.4	3.83	2.01

3A version also available (Ra ≤ 0.8 μm/150 grit, option: Ra ≤ 0.4 μm/240 grit)  
All dimensions in [in]

1/2"-Tri-Clamp: 1.4404 (316/316L)					
DN	Clamp	G	L	U	di
3/8"	1/2"	0.98	14.4	0.37	0.21
1/2"	1/2"	0.98	15.7	0.37	0.33

3A version also available (Ra ≤ 0.8 μm/150 grit, option: Ra ≤ 0.4 μm/240 grit)  
All dimensions in [in]

## SMS 1145 (Threaded hygienic connection)

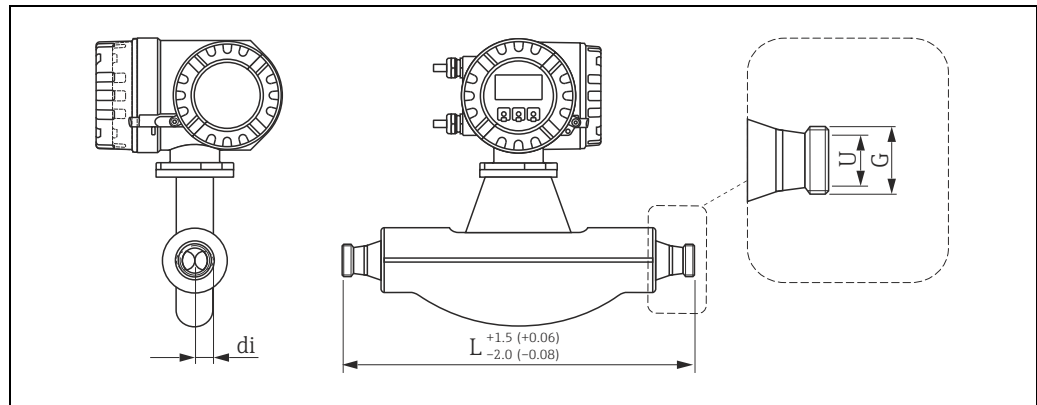

Dimension unit in mm (in)

Threaded hygienic connection SMS 1145: 1.4404 (316/316L)				
DN	G	L	U	di
3/8"	Rd 40 × 1/6"	14.45	0.89	0.214
1/2"	Rd 40 × 1/6"	15.67	0.89	0.332
1"	Rd 40 × 1/6"	17.09	0.89	0.480
1 1/2"	Rd 60 × 1/6"	22.05	1.4	0.704
2"	Rd 70 × 1/6"	28.35	1.91	0.104
3"	Rd 98 × 1/6"	35.43	2.87	1.620
4"	Rd 132 × 1/6"	44.37	3.84	2.048

3A version also available (Ra ≤ 0.8 μm/150 grit, option: Ra ≤ 0.4 μm/240 grit)  
All dimensions in [in]

VCO connections

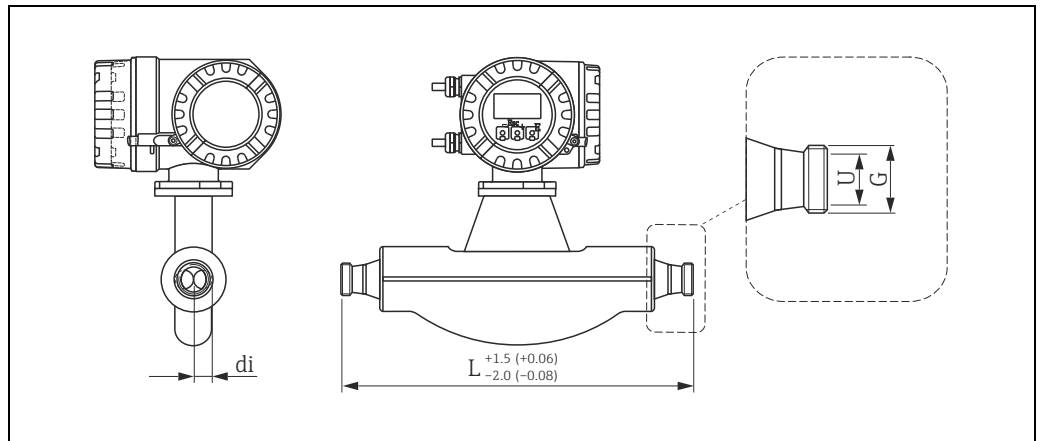

A0022587

Dimension unit in mm (in)

8-VCO-4 (1/2"): 1.4404 (316/316L)				
DN	G	L	U	di
3/8"	AF 1"	15.35	0.40	0.21

All dimensions in [in]

12-VCO-4 (3/4"): 1.4404 (316/316L)				
DN	G	L	U	di
1/2"	AF 1 1/2"	16.93	0.62	0.33

All dimensions in [in]

**Purge connections / secondary containment monitoring**



Caution!

Purge connections or secondary containment monitoring can not be combined with separately available heating jacket.

*Dimensions (not available for the Promass F high-temperature version)*

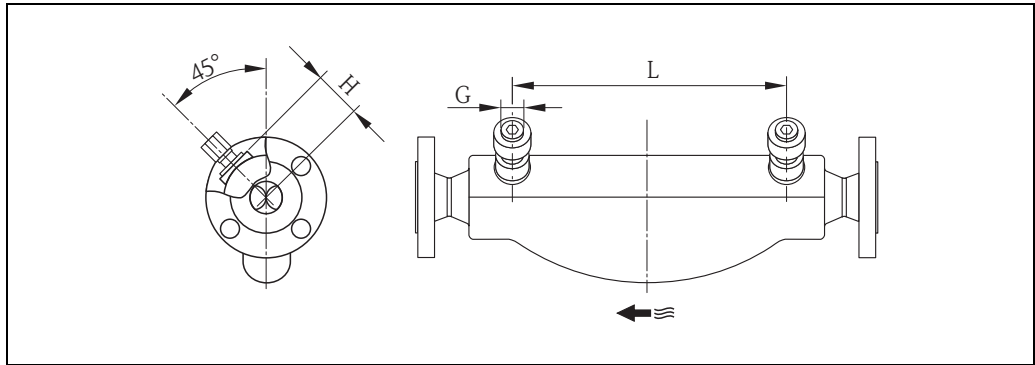

a0002537

DN 8 bis DN 150 (3/8" to 6")

DN		G	H		L	
[mm]	[in]		[mm]	[in]	[mm]	[in]
8	3/8	1/2"-NPT	62	2.44	216	8.50
15	1/2	1/2"-NPT	62	2.44	220	8.66
25	1	1/2"-NPT	62	2.44	260	10.24
40	1 1/2	1/2"-NPT	67	2.64	310	12.20
50	2	1/2"-NPT	79	3.11	452	17.78
80	3	1/2"-NPT	101	3.98	560	22.0
100	4	1/2"-NPT	120	4.72	684	27.0
150	6	1/2"-NPT	141	5.55	880	34.6

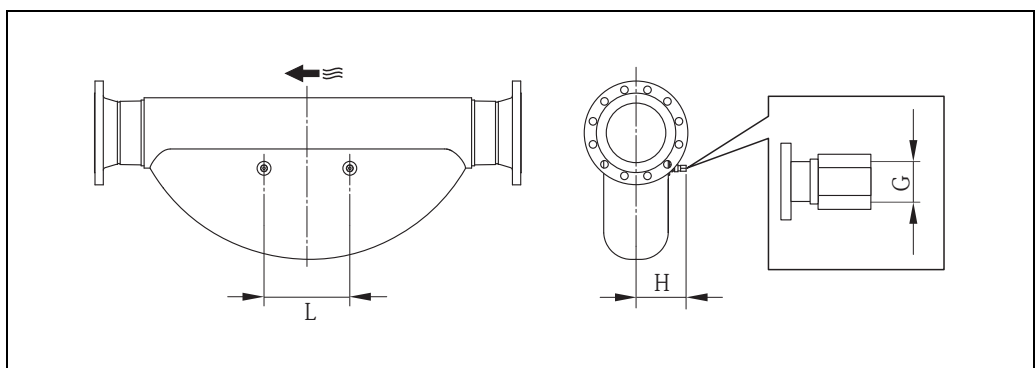

a0009734

DN 250 (10")

DN		G	H		L	
[mm]	[in]		[mm]	[in]	[mm]	[in]
250	10	1/2"-NPT	182	7.17	380	14.96



**Weight**

- Compact version: see tables below
- Remote version
  - Sensor: see the tables below
  - Wall-mount housing: 5 kg (11 lbs)

**Weight information in SI units**

DN [mm]	8	15	25	40	50	80	100	150	250 <sup>1)</sup>
Compact version	11	12	14	19	30	55	96	154	400
High temperature compact version	-	-	14.7	-	30.7	55.7	-	-	-
Compact version Ex d	20	21	23	28	39	64	105	163	409
Remote version	9	10	12	17	28	53	94	152	398
High temperature remote version	-	-	13.5	-	29.5	54.5	-	-	-

<sup>1)</sup>With 10" according to ASME B16.5 Cl 300 flanges  
 All values (weight) refer to devices with EN/DIN PN 40 flanges.  
 Weight information in [kg].

**Weight information in US**

DN [in]	3/8	1/2	1	1 1/2	2	3	4	6	10 <sup>1)</sup>
Compact version	24	26	31	42	66	121	212	339	882
High temperature compact version	-	-	32	-	68	123	-	-	-
Compact version Ex d	44	46	51	62	86	141	232	359	902
Remote version	20	22	26	37	62	117	207	335	877
High temperature Remote version	-	-	29	-	65	120	-	-	-

<sup>1)</sup> With 10" according to ASME B16.5 Cl 300 flanges  
 All values (weight) refer to devices with EN/DIN PN 40 flanges.  
 Weight information in [lbs].

**Material**

**Transmitter housing**

Compact version

- Powder coated die-cast aluminium
- Stainless steel housing: stainless steel 1.4301/ASTM 304
- Stainless steel housing (II2G/Zone 1): stainless steel 1.4404/CF3M
- Window material: Glass or polycarbonate

Remote version

- Remote field housing: powder coated die-cast aluminium
- Wall-mount housing: powder coated die-cast aluminium
- Window material: Glass

**Sensor housing / containment**

- Acid and alkali-resistant outer surface
- Stainless Steel 1.4307 (304L)

**Connection housing, sensor (remote version)**

- Stainless Steel 1.4301 (304) (standard)
- Powder coated die-cast aluminum  
 (high-temperature version and version for heating)

**Process connections**

- Stainless Steel 1.4404 (F316/F316L)
  - Flanges according to EN 1092-1 (DIN 2501) / according to ASME B16.5 / JIS B2220
- Stainless Steel 1.4404 (316/316L)
  - DIN 11864-2 Form A (aseptic flat flange with groove)
  - Threaded hygienic connection:
    - DIN 11851
    - SMS 1145
    - ISO 2853
    - DIN 11864-1 Form A
  - Tri-Clamp (OD-Tubes)
  - VCO connections
- Stainless Steel 1.4301 (F304), wetted parts: Alloy C22
  - Lap joint flange according to EN 1092-1 (DIN 2501) / according to ASME B16.5 / JIS B2220
- Alloy C22, 2.4602 (UNS N06022)
  - Flanges according to EN 1092-1 (DIN 2501) / according to ASME B16.5 / JIS B2220

*high-temperature version*

- Stainless Steel 1.4404 (316/316L)
  - Flanges according to EN 1092-1 (DIN 2501) / according to ASME B16.5 / JIS B2220
- Alloy C22, 2.4602 (UNS N06022)
  - Flanges according to EN 1092-1 (DIN 2501) / according to ASME B16.5 / JIS B2220

**Measuring tubes**

- DN 8 to 100 ( $\frac{3}{8}$ " to 4"): Stainless Steel 1.4539 (904L); manifold: 1.4404 (316/316L)
- DN 150 (6"): Stainless Steel 1.4404 (316/316L); manifold: 1.4404 (316/316L)
- DN 250 (10"): Stainless Steel 1.4404 (316/316L); manifold: CF3M/316L
- DN 8 to 150 ( $\frac{3}{8}$ " to 6"): Alloy C22, 2.4602 (UNS N06022); manifold: Alloy C22, 2.4602 (UNS N06022)

*high-temperature version*

DN 25, 50, 80: Alloy C22, 2.4602 (UNS N06022)

**Process connections****Welded process connections**

- Flanges according to EN 1092-1 (DIN 2501), according to ASME B16.5, JIS B2220, VCO connections
- Sanitary connections: Tri-Clamp, threaded hygienic connections (DIN 11851, SMS 1145, ISO 2853, DIN 11864-1 Form A), flange to DIN 11864-2 Form A (flat flange with groove)

## Operability

**Local operation****Display elements**

- Liquid-crystal display: backlit, two lines (Promass 80) or four lines (Promass 83) with 16 characters per line
- Selectable display of different measured values and status variables
- At ambient temperatures below  $-20\text{ °C}$  ( $-4\text{ °F}$ ) the readability of the display may be impaired.

**Operating elements***Promass 80*

- Local operation with three keys (□ ⊕ ⊞)
- Quick Setup menus for straightforward commissioning

*Promass 83*

- Local operation with three optical keys (□ ⊕ ⊞)
- Application-specific Quick Setup menus for straightforward commissioning

**Language group**

Language groups available for operation in different countries:

Valid until software version 3.01.xx			
Order code	Option		Contents
Power Supply; Display	WEA	Western Europe and America	English, German, Spanish, Italian, French, Dutch and Portuguese
	EES	Eastern Europe and Scandinavia	English, Russian, Polish, Norwegian, Finnish, Swedish and Czech
	SEA	South and East Asia	English, Japanese, Indonesian
	only Promass 83		
	CN	China	English, Chinese

Valid as of software version 3.07.xx (only Promass 83)		
Order code	Option	Contents
Power Supply; Display	P, Q	English, German, Spanish, Italian, French
	R, S	English, Russian, Portuguese, Dutch, Czech
	T, U	English, Japanese, Swedish, Norwegian, Finnish
	4, 5	English, Chinese, Indonesian, Polish

You can change the language group via the operating program "FieldCare".

**Remote operation**

**Promass 80**

Remote operation via HART, PROFIBUS PA

**Promass 83**

Remote operation via HART, PROFIBUS DP/PA, FOUNDATION Fieldbus, Modbus RS485

## Certificates and approvals

**CE mark**

The measuring system is in conformity with the statutory requirements of the EC Directives. Endress+Hauser confirms successful testing of the device by affixing to it the CE mark.

**C-Tick symbol**

The measuring system complies with the EMC requirements of the "Australian Communications and Media Authority (ACMA)"

**Ex approval**

Information about currently available Ex versions (ATEX, FM, CSA, IECEx, NEPSI) can be supplied by your Endress+Hauser Sales Center on request. All explosion protection data are contained in separate explosion protection documentation which you can order if required.

**Sanitary compatibility**

- 3A approval
- EHEDG-tested

**Functional safety**

SIL -2: accordance IEC 61508/IEC 61511-1 (FDIS)

"4 to 20 mA" output according to the following order code:

A, B, C, D, E, L, M, R, S, T, U, W, 0, 2, 3, 4, 5, 6, 8

See also "Terminal assignment" →  9

<b>HART certification</b>	<p>The flowmeter has successfully passed all the test procedures carried out and is certified and registered by the HCF (Hart Communication Foundation). The device thus meets all the requirements of the following specifications:</p> <ul style="list-style-type: none"> <li>■ Certified in accordance with HART Revisions 5 and 7 (device certification number: available on request)</li> <li>■ The measuring device can also be operated with certified devices of other manufacturers (interoperability).</li> </ul>
<b>FOUNDATION Fieldbus certification</b>	<p>The flowmeter has passed all the test procedures implemented and has been certified and registered by the Fieldbus Foundation. The flowmeter thus meets all the requirements of the specifications listed below:</p> <ul style="list-style-type: none"> <li>■ Certified to FOUNDATION Fieldbus specification</li> <li>■ The flowmeter meets all the specifications of the FOUNDATION Fieldbus-H1.</li> <li>■ Interoperability Test Kit (ITK), revision status 5.01 (Certification on request)</li> <li>■ The device can also be operated in conjunction with other-make certified devices.</li> <li>■ Physical Layer Conformance Test of the Fieldbus Foundation</li> </ul>
<b>PROFIBUS DP/PA certification</b>	<p>The flow device has successfully passed all the test procedures carried out and is certified and registered by the PNO (PROFIBUS User Organization). The device thus meets all the requirements of the following specifications:</p> <ul style="list-style-type: none"> <li>■ Certified to PROFIBUS Profile Version 3.0 (device certification number: on request)</li> <li>■ The device can also be operated with certified devices of other manufacturers (interoperability)</li> </ul>
<b>Modbus certification</b>	<p>The measuring device meets all the requirements of the Modbus/TCP conformity and integration test and has the "Modbus/TCP Conformance Test Policy, Version 2.0". The measuring device has successfully passed all the test procedures carried out and is certified by the "Modbus/TCP Conformance Test Laboratory" of the University of Michigan.</p>
<b>Pressure measuring device approval</b>	<p>The measuring devices can be ordered with or without PED (Pressure Equipment Directive). If a device with PED is required, this must be ordered explicitly. For devices with nominal diameters less than or equal to DN 25 (1"), this is neither possible nor necessary.</p> <ul style="list-style-type: none"> <li>■ With the identification PED/G1/III on the sensor nameplate, Endress+Hauser confirms conformity with the "Basic safety requirements" of Appendix I of the Pressure Equipment Directive 97/23/EC.</li> <li>■ Devices with this identification (with PED) are suitable for the following types of fluid: <ul style="list-style-type: none"> <li>- Fluids of Group 1 and 2 with a steam pressure greater than, or smaller and equal to 0.5 bar (7.3 psi)</li> <li>- Unstable gases</li> </ul> </li> <li>■ Devices without this identification (without PED) are designed and manufactured according to good engineering practice. They correspond to the requirements of Art. 3, Section 3 of the Pressure Equipment Directive 97/23/EC. Their application is illustrated in Diagrams 6 to 9 in Appendix II of the Pressure Equipment Directive 97/23/EC.</li> </ul>
<b>Other standards and guidelines</b>	<ul style="list-style-type: none"> <li>■ EN 60529 Degrees of protection by housing (IP code)</li> <li>■ IEC/EN 60068-2-6 Environmental influences: Test procedure - Test Fc: vibrate (sinusoidal)</li> <li>■ IEC/EN 60068-2-31 Environmental influences: Test procedure - Test Ec: shocks due to rough handling, primarily for devices</li> <li>■ EN 61010-1 Protection Measures for Electrical Equipment for Measurement, Control, Regulation and Laboratory Procedures</li> <li>■ EN 61508 Functional safety of electrical/electronic/programmable electronic safety-related systems</li> <li>■ IEC/EN 61326 "Emission in accordance with Class A requirements". Electromagnetic compatibility (EMC requirements)</li> <li>■ NAMUR NE 21 Electromagnetic compatibility (EMC) of industrial process and laboratory control equipment</li> </ul>

- NAMUR NE 43  
Standardization of the signal level for the breakdown information of digital transmitters with analog output signal
- NAMUR NE 53  
Software of field devices and signal-processing devices with digital electronics
- NACE MR 103  
Materials resistant to sulfide stress cracking in corrosive petroleum refining environments
- NACE MR 0175/ISO 15156-1  
Materials for use in H<sub>2</sub>S-containing Environments in Oil and Gas Production

## Ordering Information

Detailed ordering information is available from the following sources:

- In the Product Configurator on the Endress+Hauser website: [www.endress.com](http://www.endress.com) → Select country → Instruments → Select device → Product page function: Configure this product
- From your Endress+Hauser Sales Center: [www.endress.com/worldwide](http://www.endress.com/worldwide)



Note!

### Product Configurator - the tool for individual product configuration

- Up-to-the-minute configuration data
- Depending on the device: Direct input of measuring point-specific information such as measuring range or operating language
- Automatic verification of exclusion criteria
- Automatic creation of the order code and its breakdown in PDF or Excel output format
- Ability to order directly in the Endress+Hauser Online Shop

## Accessories

Various accessories, which can be ordered with the device or subsequently from Endress+Hauser, are available for the device. Detailed information on the order code in question is available from your local Endress+Hauser sales center or on the product page of the Endress+Hauser website:

[www.endress.com](http://www.endress.com).

### Device-specific accessories

#### For the Transmitter

Accessories	Description
Transmitter	Transmitter for replacement or for stock. Use the order code to define the following specifications: <ul style="list-style-type: none"> <li>- Approvals</li> <li>- Degree of protection / version</li> <li>- Cable entries,</li> <li>- Display / power supply / operation</li> <li>- Software</li> <li>- Outputs / inputs</li> </ul>
Inputs/outputs for Proline Promass 83 HART	Conversion kit with appropriate plug-in point modules for converting the input/output configuration in place to date to a new version.
Software packages for Proline Promass 83	Software add-ons on F-Chip, can be ordered individually: <ul style="list-style-type: none"> <li>- Advanced diagnostics</li> <li>- Batching functions</li> <li>- Concentration measurement</li> </ul>
Mounting set for transmitter	Mounting set for wall-mount housing (remote version). Suitable for: <ul style="list-style-type: none"> <li>- Wall mounting</li> <li>- Pipe mounting</li> <li>- Installation in control panel</li> </ul> Mounting set for aluminum field housing: Suitable for pipe mounting (3/4" to 3")

#### For the Sensor

Accessories	Description
Heating jacket	Is used to stabilize the temperature of the fluids in the sensor. Water, water vapor and other non-corrosive liquids are permitted for use as fluids. If using oil as a heating medium, please consult with Endress+Hauser. Heating jackets cannot be used with sensors fitted with a rupture disk.  For details, see Operating Instructions BA132D

**Communication-specific accessories**

Accessories	Description
HART Communicator Field Xpert handheld terminal	Handheld terminal for remote parameterization and for obtaining measured values via the current output HART (4 to 20 mA).  Contact your Endress +Hauser representative for more information.
Commubox FXA195 HART	The Commubox FXA195 connects intrinsically safe smart transmitters with the HART protocol with the USB port of a personal computer. This enables remote operation of the transmitter with operating software (e.g. FieldCare). Power is supplied to the Commubox via the USB port.

**Service-specific accessories**

Accessories	Description
Applicator	Software for selecting and sizing Endress+Hauser measuring devices: <ul style="list-style-type: none"> <li>▪ Calculation of all the necessary data for identifying the optimum flowmeter: e.g. nominal diameter, pressure loss, accuracy or process connections</li> <li>▪ Graphic illustration of the calculation results</li> </ul> Administration, documentation and access to all project-related data and parameters over the entire life cycle of a project.  Applicator is available: <ul style="list-style-type: none"> <li>▪ Via the Internet: <a href="https://wapps.endress.com/applicator">https://wapps.endress.com/applicator</a></li> <li>▪ On CD-ROM for local PC installation</li> </ul>
W@M	Life cycle management for your plant. W@M supports you with a wide range of software applications over the entire process: from planning and procurement, to the installation, commissioning and operation of the measuring devices. All the relevant device information, such as the device status, spare parts and device-specific documentation, is available for every device over the entire life cycle. The application already contains the data of your Endress+Hauser device. Endress+Hauser also takes care of maintaining and updating the data records.  W@M is available: <ul style="list-style-type: none"> <li>▪ Via the Internet: <a href="http://www.endress.com/lifecyclemanagement">www.endress.com/lifecyclemanagement</a></li> <li>▪ On CD-ROM for local PC installation</li> </ul>
Fieldcheck	Tester/simulator for testing flowmeters in the field. When used in conjunction with the "FieldCare" software package, test results can be imported into a database, printed and used for official certification. Contact your Endress+Hauser representative for more information.
FieldCare	FieldCare is Endress+Hauser's FDT-based plant asset management tool and allows the configuration and diagnosis of intelligent field devices. By using status information, you also have a simple but effective tool for monitoring devices. The Proline flowmeters are accessed via a service interface or via the service interface FXA193.
FXA193	Service interface from the measuring device to the PC for operation via FieldCare.

**System components**

Accessories	Description
Memograph M graphic display recorder	The Memograph M graphic display recorder provides information on all the relevant process variables. Measured values are recorded correctly, limit values are monitored and measuring points analyzed. The data are stored in the 256 MB internal memory and also on a DSD card or USB stick. Memograph M boasts a modular design, intuitive operation and a comprehensive security concept. The ReadWin® 2000 PC software is part of the standard package and is used for configuring, visualizing and archiving the data captured. The mathematics channels which are optionally available enable continuous monitoring of specific power consumption, boiler efficiency and other parameters which are important for efficient energy management.

## Documentation

- Flow measuring technology (FA00005D)
- Technical Information
  - Promass 80A, 83A (TI00054D)
  - Promass 80E, 83E (TI00061D)
  - Promass 80H, 83H (TI00074D)
  - Promass 80I, 83I (TI00075D)
  - Promass 80M, 83M (TI00102D)
  - Promass 80P, 83P (TI00078D)
  - Promass 80S, 83S (TI00076D)
- Operating Instructions/Description of Device Functions
  - Promass 80 HART (BA00057D/BA00058D)
  - Promass 80 PROFIBUS PA (BA00072D/BA00073D)
  - Promass 83 HART (BA00059D/BA00060D)
  - Promass 83 FOUNDATION Fieldbus (BA00065D/BA00066D)
  - Promass 83 PROFIBUS DP/PA(BA00063D/BA00064D)
  - Promass 83 Modbus (BA00107D/BA00108D)
- Supplementary documentation on Ex-ratings: ATEX, FM, CSA, IECEx NEPSI
- Functional safety manual Promass 80, 83 (SD00077D)

## Registered trademarks

KALREZ® and VITON®

Registered trademarks of E.I. Du Pont de Nemours & Co., Wilmington, USA

TRI-CLAMP®

Registered trademark of Ladish & Co., Inc., Kenosha, USA

SWAGELOK®

Registered trademark of Swagelok & Co., Solon, USA

HART®

Registered trademark of HART Communication Foundation, Austin, USA

PROFIBUS®

Registered trademark of the PROFIBUS User Organization, Karlsruhe, Germany

FOUNDATION™ Fieldbus

Registered trademark of the Fieldbus FOUNDATION, Austin, USA

Modbus®

Registered trademark of the SCHNEIDER AUTOMATION, INC.

Applicator®, FieldCare®, Fieldcheck®, HistoROM™, F-CHIP®, S-DAT®, T-DAT™

Registered or registration-pending trademarks of the Endress+Hauser Group



[www.addresses.endress.com](http://www.addresses.endress.com)

---